

INDEX SETS

ZS 160/00	>> Retinal Detachment
ZS 160/05	>> Astigmatic Keratotomy AK
ZS 160/10	>> Chalazion
ZS 160/15	>> Dacryocystorhinostomy D.C.R Lacrimal
ZS 160/20	>> Enucleation
ZS 160/25	>> Stitch Removal
ZS 160/30	>> Foreign Body
ZS 160/35	>> Glaucoma
ZS 160/40	>> Cataract E.C.
ZS 160/45	>> Cataract Phacoemulsification
ZS 160/50	>> Keratoplasty
ZS 160/55	>> Lasik
ZS 160/60	>> Lid-Conjunctiva / Trichiasis-Ptosis
ZS 160/65	>> Emergency
ZS 160/70	>> Pterygium
ZS 160/75	>> Radiale Keratotomy RK
ZS 160/80	>> Strabismus / Muscle
ZS 160/85	>> Vitrectomy -Pars Plana-

Sets

OPHTHALMOLOGY

	SET
Retinal Detachment	ZS 160/00
Astigmatic Keratotomy AK Set	ZS 160/05
Chalazion Set	ZS 160/10
Dacryocystorhinostomy D.C.R. Lacrimal	ZS 160/15
Enucleation	ZS 160/20
Stitch Removal	ZS 160/25
Foreign Body	ZS 160/30
Glaucoma	ZS 160/35
Cataract E.C.	ZS 160/40
Cataract Phacoemulsification	ZS 160/45
Keratoplasty	ZS 160/50
Lasik	ZS 160/55
Lid-Conjunctiva / Trichiasis-Ptosis	ZS 160/60
Emergency	ZS 160/65
Pterygium	ZS 160/70
Radiale Keratotomy RK	ZS 160/75
Strabismus / Muscle	ZS 160/80
Vitreotomy -Pars Plana-	ZS 160/85



ZS 160/00 RETINAL DETACHMENT SET

Contents:		Qty
AA 060/06	DIEFFENBACH BULLDOG CLAMPS STR 6,0 CM	2
AA 151/12	HALSTED-MOSQUITO FCPS CVD 12,5 CM	1
AA 751/08	BACKHAUS TOWEL FORCEPS 8,0 CM	2
AB 710/07	GRAEFE IRIS FORCEPS STR SERR. 7,0 CM	1
AB 714/07	GRAEFE IRIS FORCEPS STR 1X2 TEETH 700 CM	1
AB 750/07	BARRAQUER-KATZIN FIX.FCPS 1X2 T. 7,0 CM	1
AB 792/11	ELSCHNIG FIXATION FORCPES 1X2 TEETH 11,0 CM	1
AB 816/01	CASTROVIEJO SUTURE FORCEPS 0,12 MM 10,0CM	1
AB 825/02	BONN SUTURE FORCEPS 10,0 CM ULRTA FINE	1
AB 825/02	BONN SUTURE FORCEPS 10,0 CM ULRTA FINE	1
AB 828/10	PAUFIQUE SUTURE FORCEPS 1X2 TEETH 10,0 CM	1
AB 833/01	JAMESON MUSCULAR FORCEPS 10,0 CM RIGHT	1
AB 833/02	JAMESON MUSCULAR FORCEPS 10,0 CM LEFT	1
AC 461/11	STRABISMUS SCISSORS CVD BLUNT 11,5 CM	1
AC 466/10	IRIS SCISSORS STR W LARGE BOWS 10,0 CM	1
AC 768/05	BARRAQUER EYE SCISSORS 5,5 CM 5,0 MM	1
AC 780/11	WESTCOTT TENOTOMY SCS.POINTED 11,0 CM	1
AC 782/11	WESTCOTT TENOTOMY SCISSORS BLUNT 11,0 CM	1
AD 075/11	PCK=100 BLADES FIG. 11	1
AD 550/09	BLADE BREAKER 9.0 CM DIA 5,5 MM	1
AE 605/14	BARRAQUER MICRO-NEEDLE HOLDER CVD 14,0 CM	1
AE 607/14	BARRAQUER MICRO-NH CVD RA 14,0 CM	1
AE 652/09	CASTROVIEJO NH STR RA 9,0 CM	1
AR 250/15	MEASURING INSTRUMENT 15,0 CM	1
AR 282/20	CASTROVIEJO CIRCLE 8,0 CM STRAIGHT	1
KP 001/13	GREEN STRABISMUS HOOK 13,0 CM	1
KP 002/12	JAMESON MUSCLE HOOK 12,0 CM	1
KP 010/14	GASS RETINAL DETACHMENT HOOK 14,0 CM	1
KP 015/01	GRAEFE STRABISMUS HOOK #1 13,0 CM	1
KP 015/02	GRAEFE STRABISMUS HOOK #2 14,0 CM	1
KP 015/03	GRAEFE STRABISMUS HOOK #3 15,0 CM	1
KP 150/15	BARRAQUER-COLIBRI EYE SPECULA 15 MM 4,0 CM	1
KP 261/15	SAUTTER ORBITAL SPATUL MEDIUM 15,0 CM	1
KP 495/13	WECKER IRIS SPATULA 2MM SILVER 13,0 CM	1
KP 542/01	SCHIOETZ TONOMETER STRAIGHT SCALE	1
SK 305/05	WIRE BASKET, 485 X 255 X 50 MM	1

Sterilization Container KYE 200/61, if required





AA 060/06
6,0 cm/2 1/2"

DIEFFENBACH



HALSTED-MOSQUITO
AA 151/12
12,5 cm/5"



BACKHAUS
AA 751/08
8,0 cm/3"



GRAEFE



AB 710/07
7,0 cm/2 3/4"



AB 714/07
7,0 cm/2 3/4"

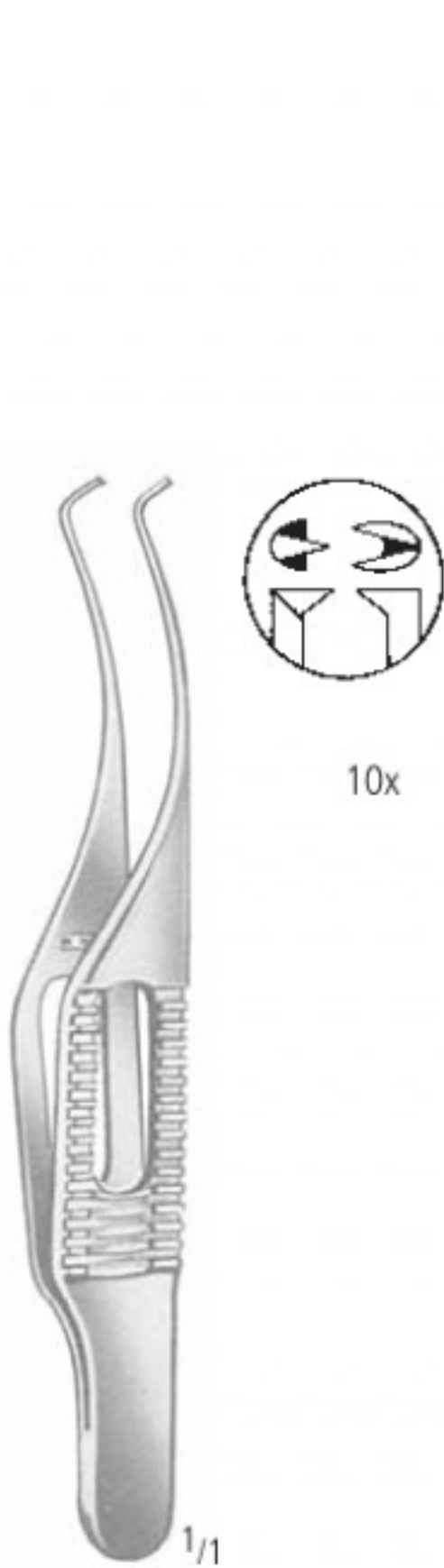

BARRAQUER-KATZIN 1:2 (Colibri)
AB 750/07
7,0 cm/2 3/4"



ELSCHNIG 1:2
AB 792/11
11,0 cm/4 1/3"

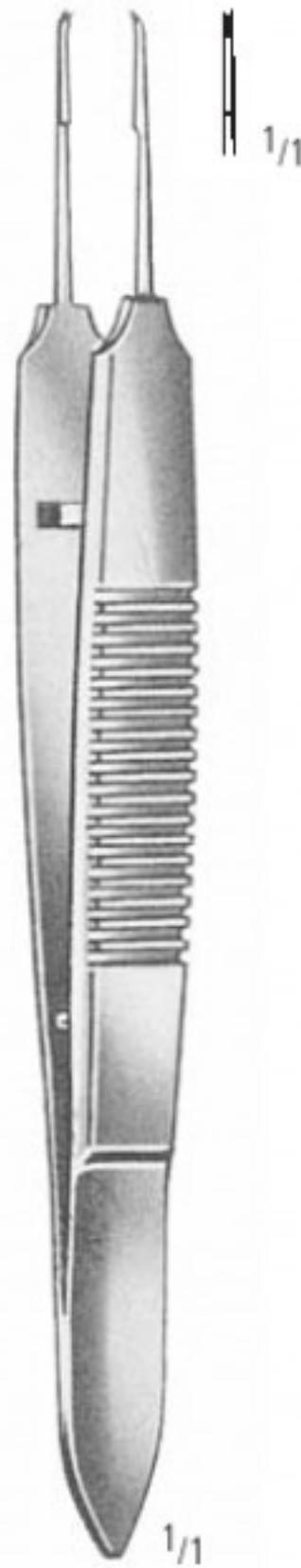

CASTROVIEJO 1:2
AB 816/01 0,12 mm
10,0 cm/4"



10 x
0,12 mm



MOD. BONN
AB 825/02
10,0 cm/4"

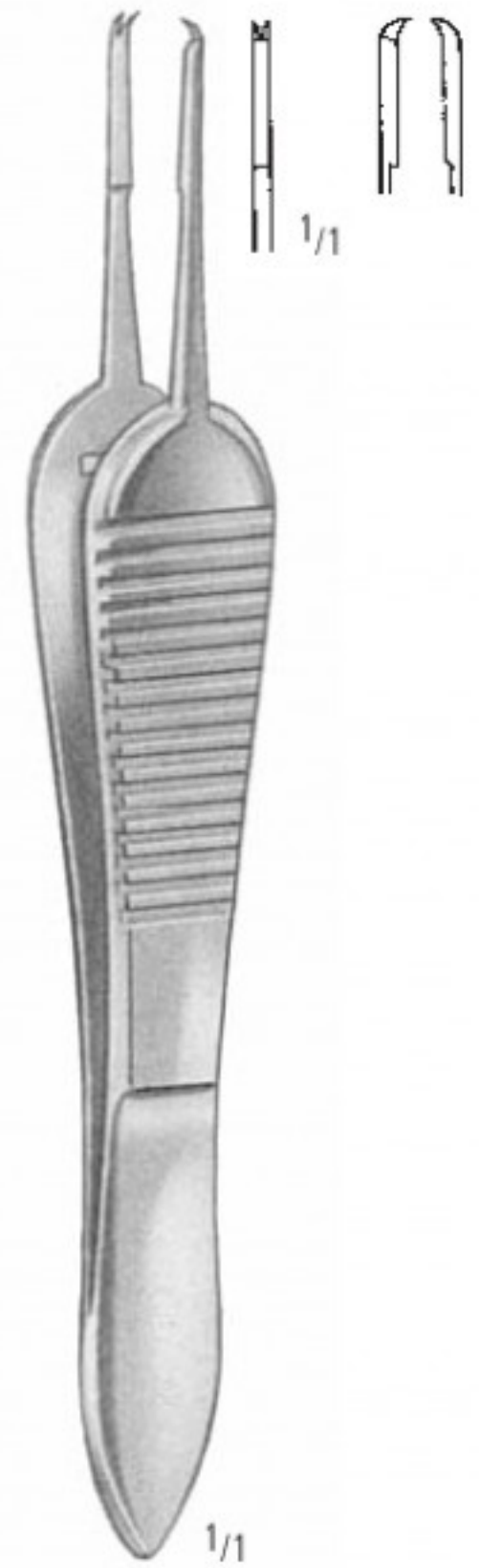

PAUFIQUE 1:2
AB 828/10
10,0 cm/4"

ZS 160/00 RETINAL DETACHMENT SET

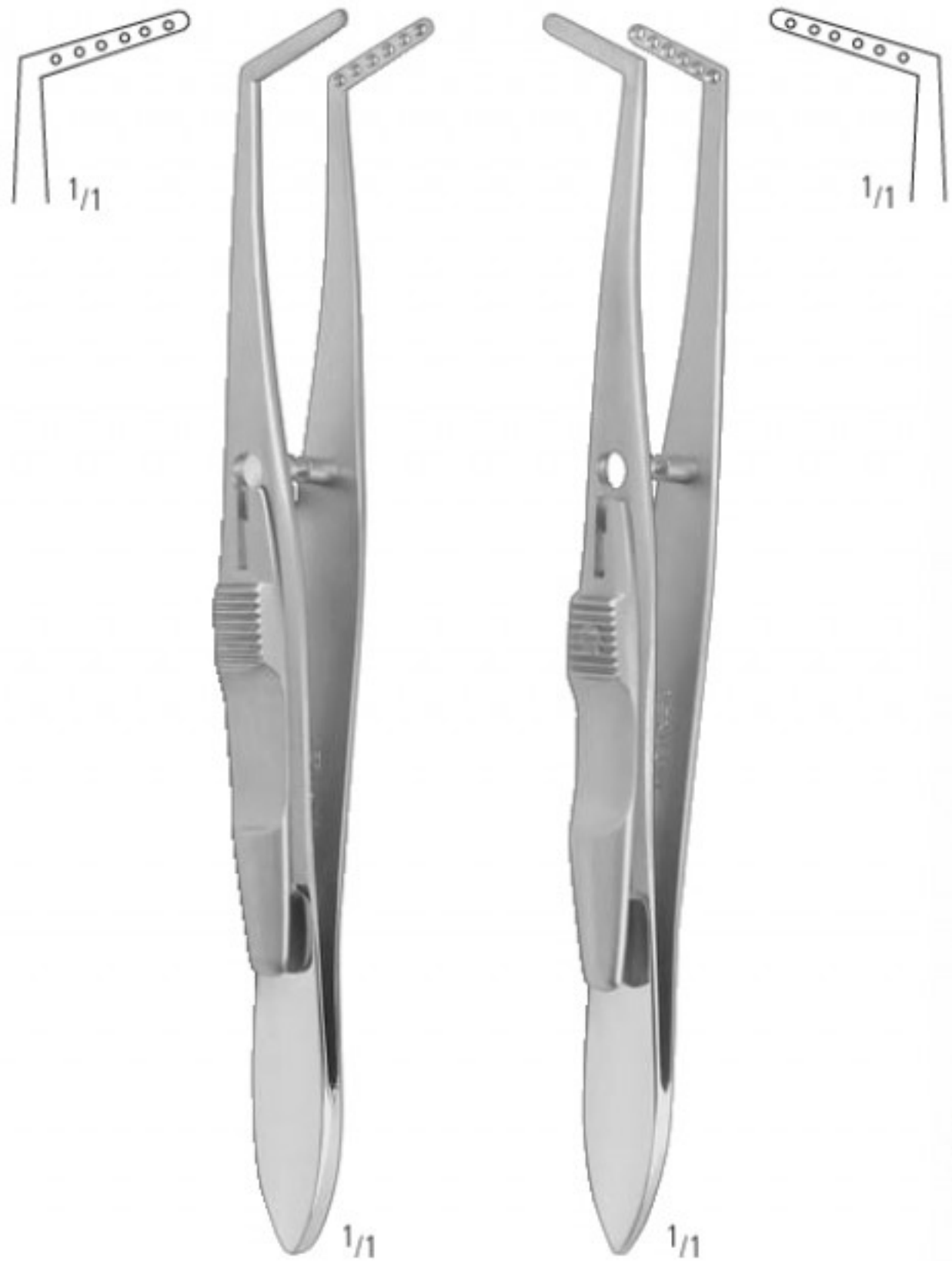

Strabismusscheren
Strabismus Scissors
Tijeras para estrabismos
Ciseaux à strabisme
Forbici per strabismo

mit großen Ringen
with large bows
con anillos grandes
avec grands anneaux
con anelli grandi

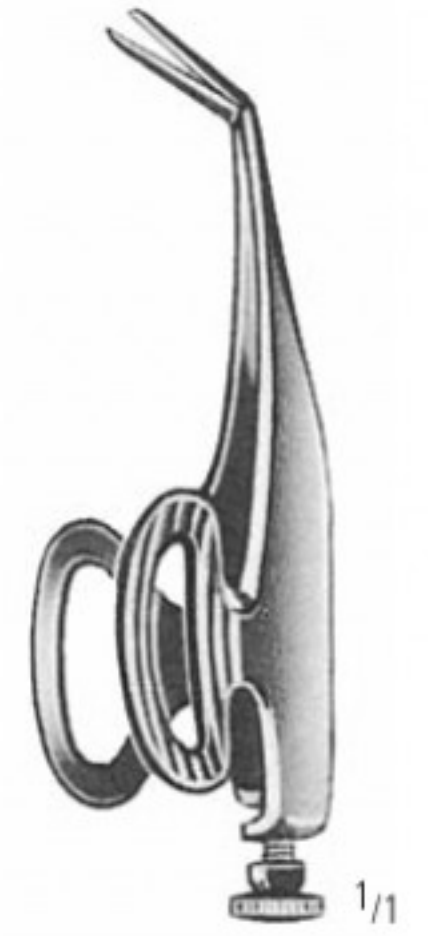

JAMESON
AB 833/01
10,0 cm/4"

JAMESON
AB 833/02
10,0 cm/4"

AC 461/11
11,5 cm/4¹/₂"

AC 466/10
10,0 cm/4"

BARRAQUER
5,5 cm/2¹/₄"
AC 768/05
5 mm



Fig. 11
AD 075/11

steril
sterile
estériles
stériles
sterili

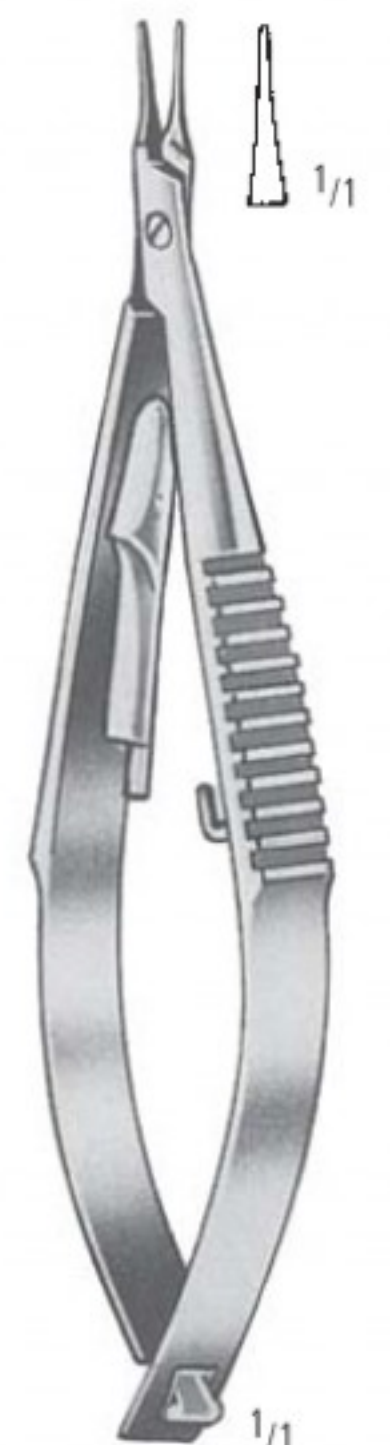

WESTCOTT
AC 780/11
11,0 cm/4¹/₃"

WESTCOTT
AC 782/11
11,0 cm/4¹/₃"

TROUTMAN-CHRIS
AD 550/09
Ø 5,5 mm
9,0 cm/3¹/₂"

BARRAQUER
AE 605/14
14,0 cm/5¹/₂"

BARRAQUER
AE 607/14
14,0 cm/5¹/₂"

CASTROVIEJO
AE 652/09
9,0 cm/3¹/₂"



Messbereich 20 mm
measuring range 20 mm
campo de medición 20 mm
étendue de mesurage 20 mm
ampiezza di misura 20 mm



AR 250/15
15,0 cm/6"

CASTROVIEJO
AR 282/20
8,0 cm/ 3"

Erwachsene
Adults
Adultos
Adultes
Adulti

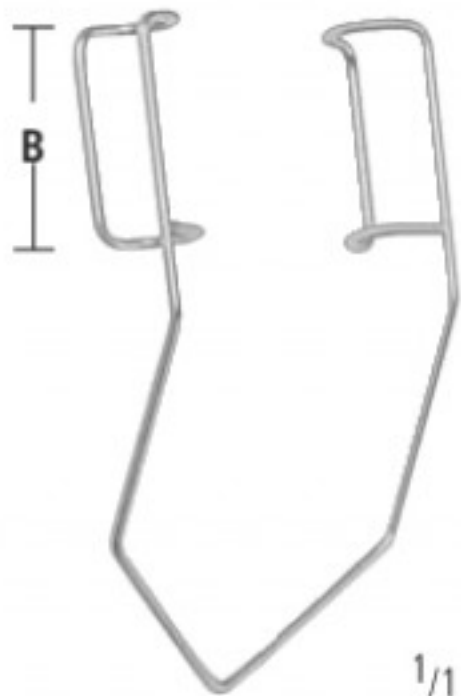

BARRAQUER-COLIBRI
B
15 mm
KP 150/15
4,0 cm/1 1/2"



GREEN
KP 001/13
13,0 cm/5"



JAMESON
KP 002/12
12,0 cm/4 3/4"



GASS
KP 010/14
14,0 cm/5 1/2"

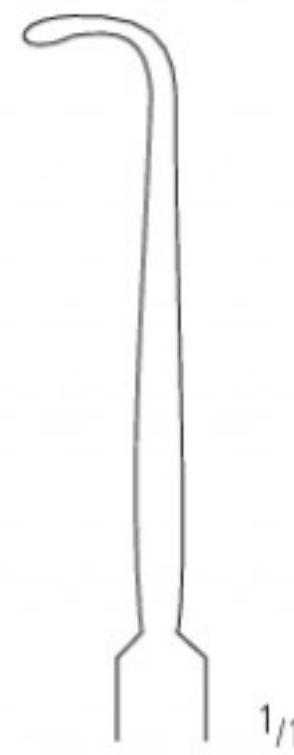

GRAEFE
KP 015/01
13,0 cm/5"
Fig. 1

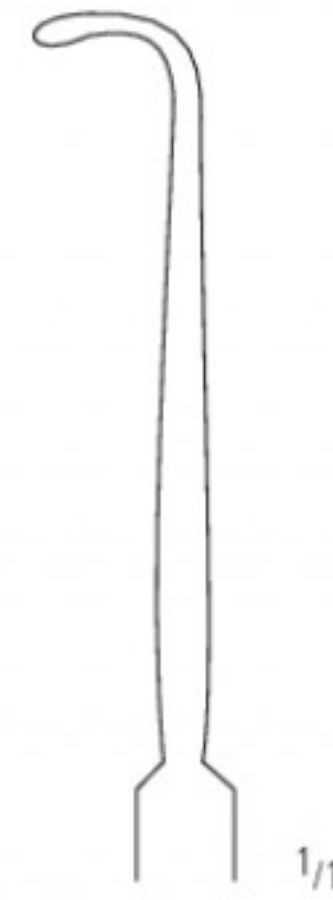

GRAEFE
KP 015/02
14,0 cm/5 1/2"
Fig. 2

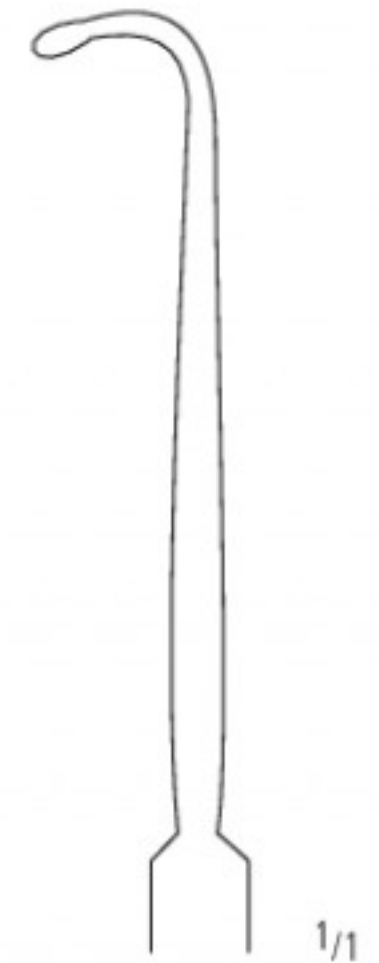

GRAEFE
KP 015/03
15,0 cm/6"
Fig. 3

ZS 160/00 RETINAL DETACHMENT SET



SAUTTER
KP 261/15
15,0 cm/6"



WECKER
KP 495/13
13,0 cm/5"
2 mm

biegsam
malleable
maleable
malléable
malleabile



gerade Skala
straight scale
graduado recto
échelle droite
scala retta

SCHIOETZ
KP 542/01
13,0 cm/5"

Spezifikation Nr. 5, geeicht
Specification No. 5, calibrated
Especificación No. 5, calibrada
Spécification No. 5, calibrée
Specifica No. 5, calibrata

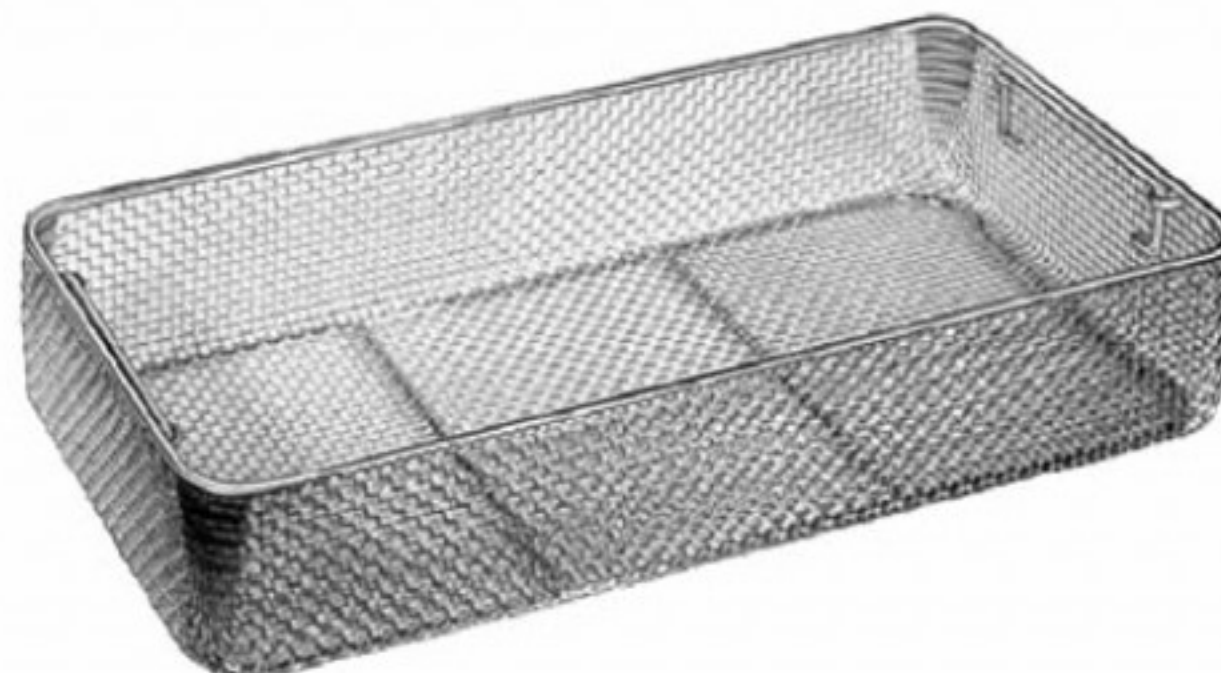

L(mm)	B(mm)	H(mm)	
485	255	50	SK 305/05

ZS 160/05 ASTIGMATIC KERATOTOMY AK SET

Contents:		Qty
AB 750/07	BARRAQUER-KATZIN FIX.FCPS 1X2 T. 7,0 CM	1
KP 154/04	BARRAQUER PHACO EYE SPECULA 4,0 CM	1
KP 375/01	PREMIUM DIAMOND KNIFE 1,0 CM 15°	1
KP 500/70	HOFFER OPTICAL ZONE MARKER 7,0 MM 10,0 CM	1
KP 500/80	HOFFER OPTICAL ZONE MARKER 8,0 MM 10,0 CM	1
KP 508/10	BORES AXIS MARKER 10,0 CM	1
KP 515/12	LINDSTROM CORNEAL OPTICAL ZONE MARKER	1
KP 547/11	MENDEZ MEASURING INSTRUMENT DEGREE 10°C	1
KP 550/12	THORNTON FIXATION RING FG-HINGE Ø 13,0 MM	1
KP 741/23	LACRIMAL CANNULA 23G 4,0 CM CURVED	2
SK 105/05	WIRE BASKET, 255 X 245 X 50 MM	1

Sterilization Container KYE 200/11, if required





BARRAQUER-KATZIN 1:2 (Colibri)
AB 750/07
7,0 cm/2³/₄"



BARRAQUER PHAKO
KP 154/04
4,0 cm/1¹/₂"

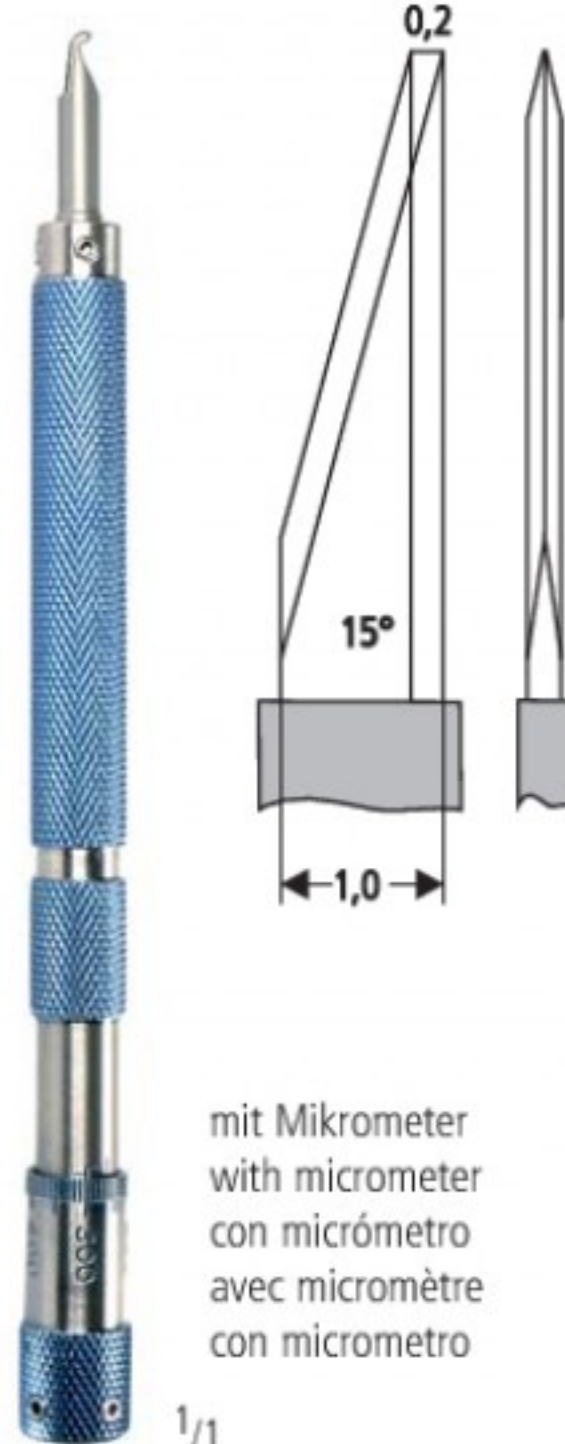

KP 375/01

mit Mikrometer
with micrometer
con micrómetro
avec micromètre
con micrometro



HOFFER
10,0 cm/4"
Ø 7,00 mm
Ø 8,00 mm

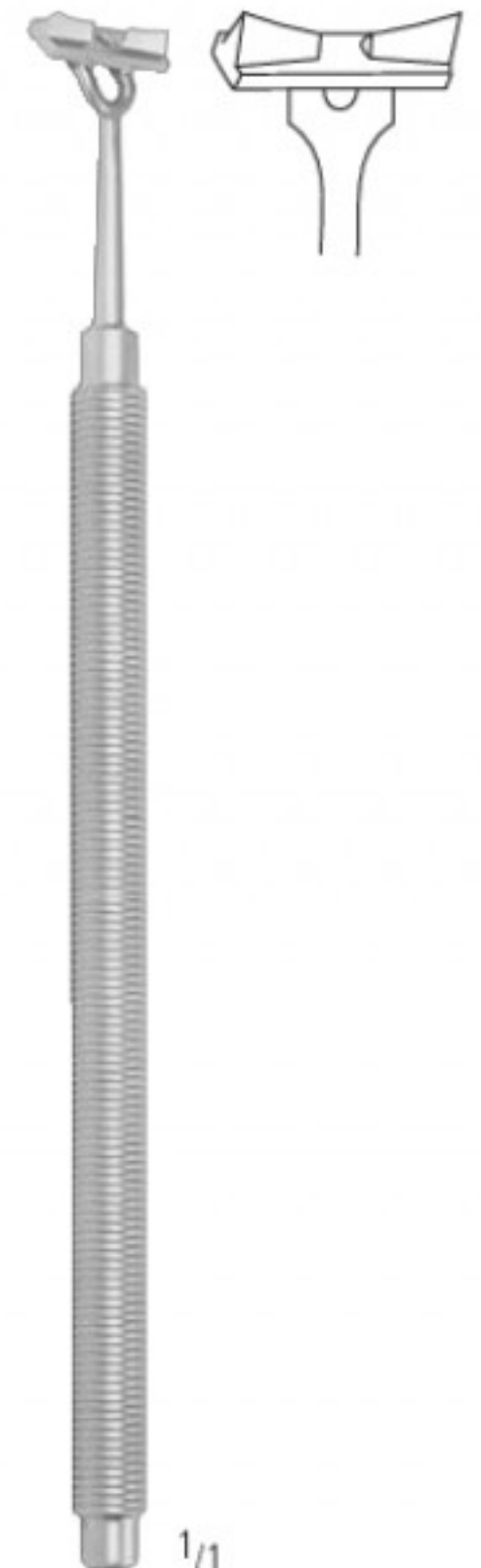

BORES
KP 508/10
10,0 cm/4"

KP 500/70
KP 500/80

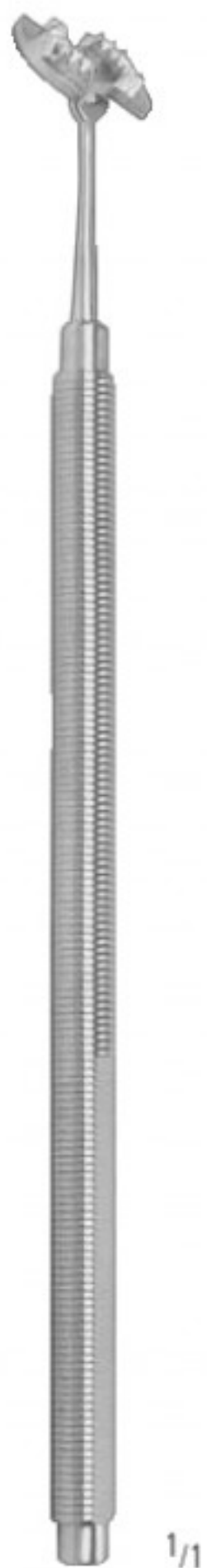

LINDSTROM
KP 515/12
12,0 cm/4³/₄"
7 mm



MENDEZ
KP 547/11
11,0 cm/4¹/₂"
C 10°, 0 -180°

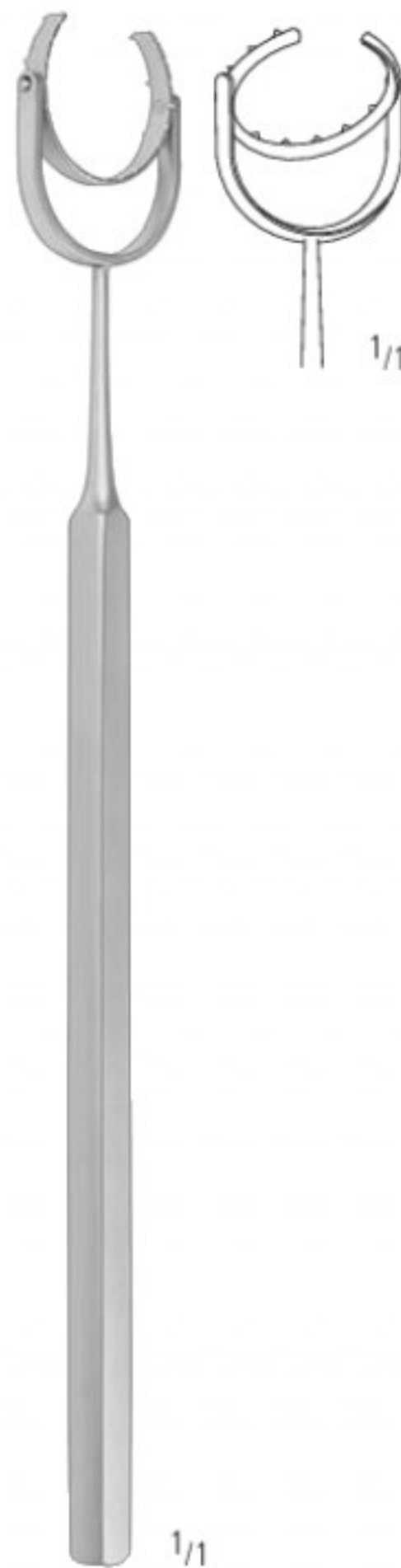

THORNTON
KP 550/12
12,0 cm/4³/₄"
Ø 13 mm



KP 741/23
3,5 cm/1¹/₂"
23G



L(mm)	B(mm)	H(mm)	
255	245	50	SK 105/05

ZS 160/10 CHALAZION SET

Contents:

Qty

AB 828/10	PAUFIQUE SUTURE FORCEPS 1X2 TEETH 10,0 CM	1
AB 840/01	DESMARRES CHALAZION FORCEPS FIG.1 9,0 CM	1
AB 840/02	DESMARRES CHALAZION FORCEPS FIG.2 9,0 CM	1
AC 467/10	IRIS SCISSORS CVD W LARGE BOWS 10,0 CM	1
AE 661/14	CASTROVIEJO NH CVD RA SMOOTH 14,0 CM	1
KP 248/11	JAEGER LID PLATE 11,0 CM	1
KP 415/10	MEYHOEFER CHALAZION CURETTE 13,0 CM	1
KP 415/20	MEYHOEFER CHALAZIONCURETTE 13,0 CM 2,0 MM	1
KP 415/25	MEYHOEFER CHALAZIONCURETTE 13,0 CM 2,5 MM	1
SK 105/05	WIRE BASKET, 255 X 245 X 50 MM	1

Sterilization Container KYE 200/11, if required



ZS 160/10 CHALAZION SET

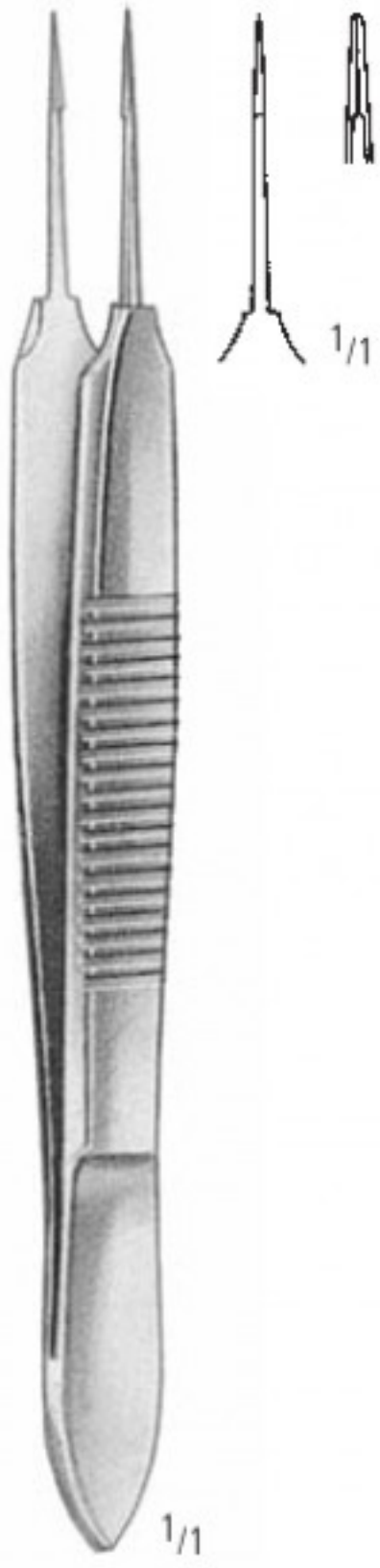

MOD. TÜBINGEN
AB 826/10
10,0 cm/4"

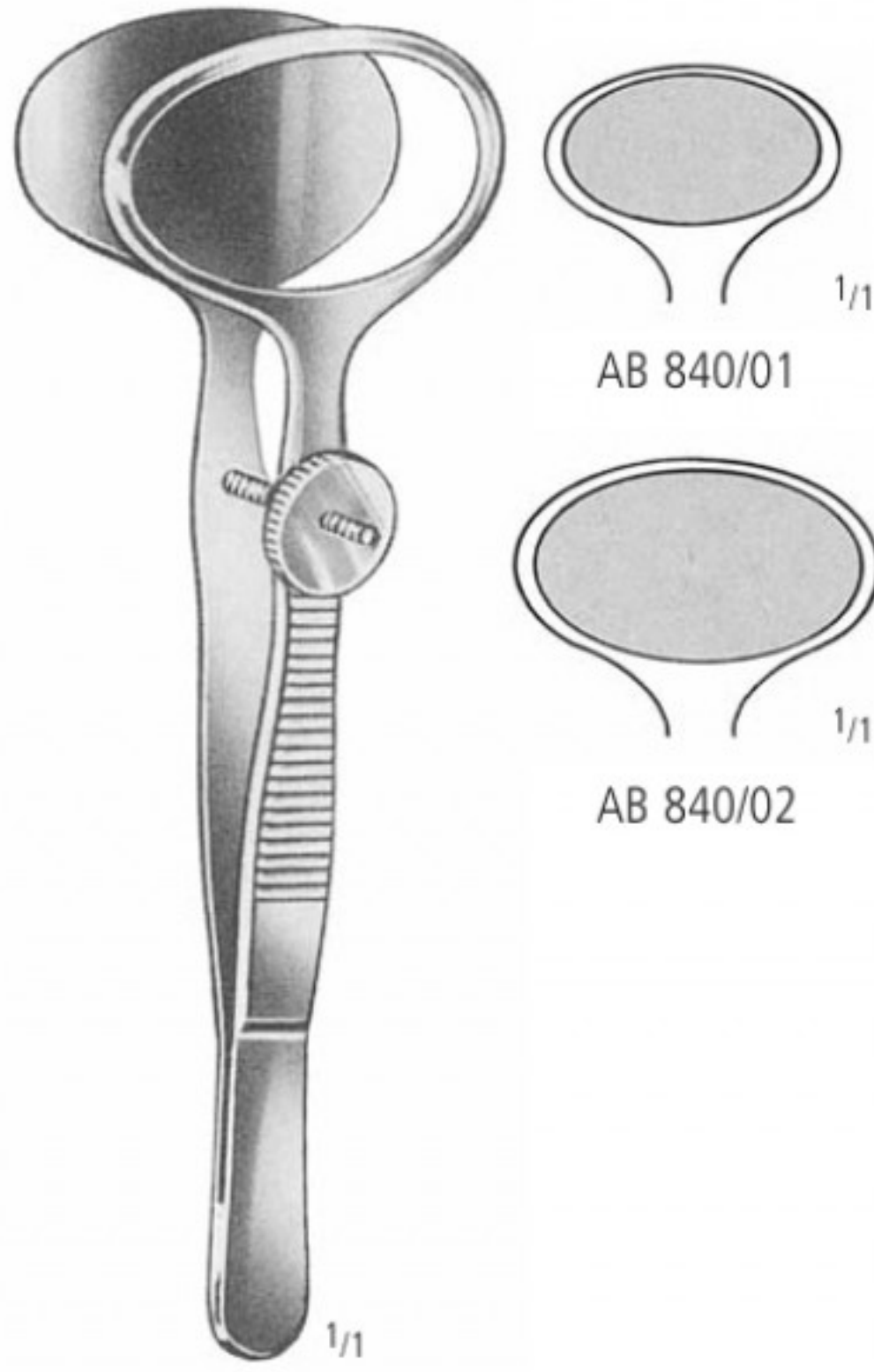

DESMARRES
9,0 cm/3 1/2"

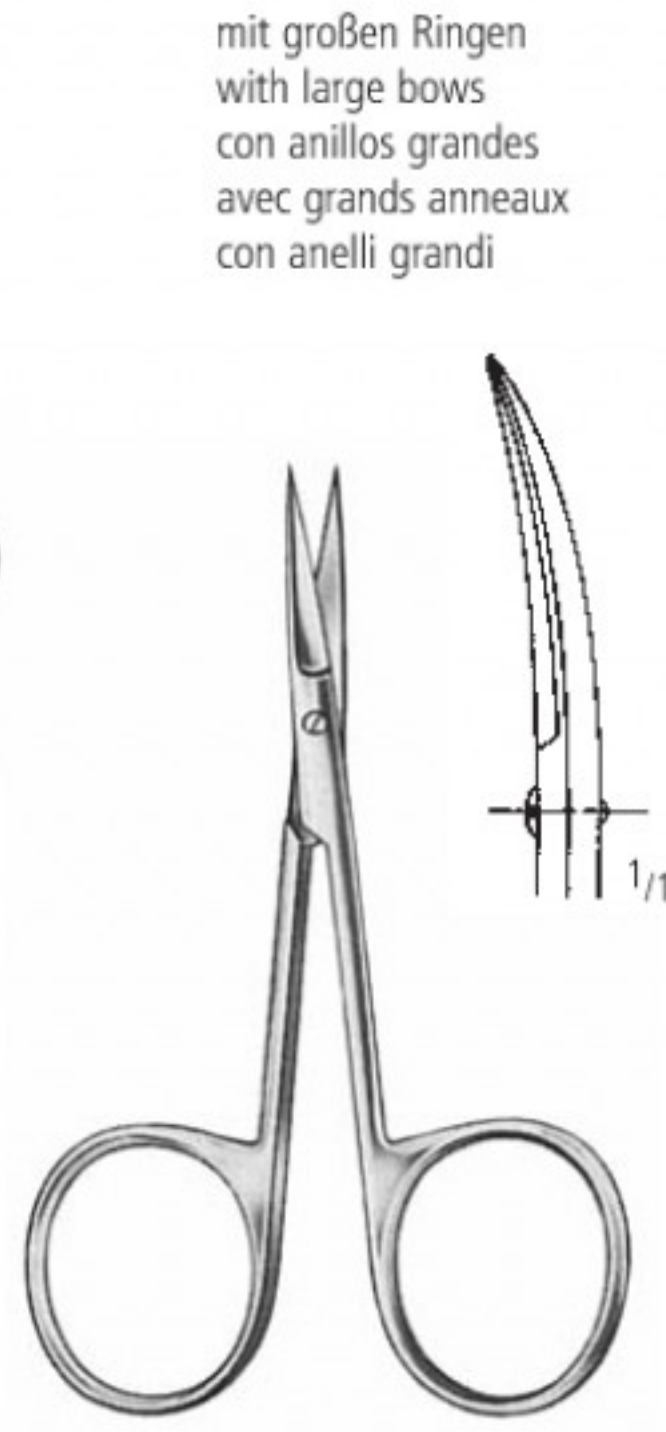

AC 467/10
10,0 cm/4"



CASTROVIEJO
AE 661/14
14,0 cm/5 1/2"



JAEGER
KP 248/11
11,0 cm/4 1/2"



MEYHOEFER
13,0 cm/5"

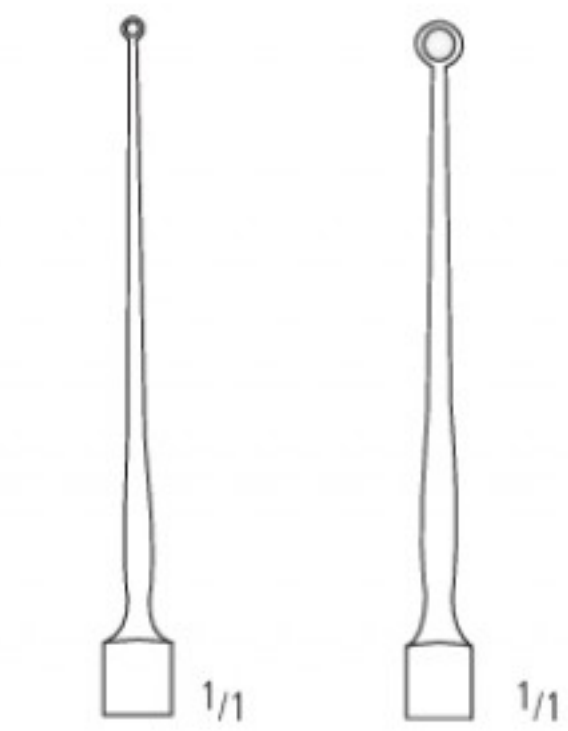

KP 415/10 Ø 1,0 mm
KP 415/20 Ø 2,0 mm



KP 415/25
Ø 2,5 mm



L(mm)	B(mm)	H(mm)	
255	245	50	SK 105/05

ZS 160/15 DACRYOCYSTORHINOSTOMY D.C.R. LACRIMAL SET

Contents:		Qty
AA 114/10	HARTMANN FORCEPS STR 10,0 CM	2
AA 115/10	HARTMANN FORCEPS CVD 10,0 CM	2
AA 751/08	BACKHAUS TOWEL FORCEPS 8,0 CM	2
AB 700/05	GRAEFE IRIS FCPS STR.SERRAT. 0,5 MM 7,0 CM	1
AB 816/01	CASTROVIEJO SUTURE FORCEPS 0,12MM 10,0 CM	1
AB 824/02	BONACCOLTO SUTURE FORCEPS 10,0 CM FINE	1
AB 828/10	PAUFIQUE SUTURE FORCEPS 1X2 TEETH 10,0 CM	1
AC 466/10	IRIS SCISSORS STR W LARGE BOWS 10,0 CM	1
AC 477/10	STEVENS TENOTOM.SCS BLUNT CVD 10,5 CM	1
AC 773/10	CASTROVIEJO IRIS SCISSORS 10,0 CM SH	1
AE 661/14	CASTROVIEJO NH CVD RA SMOOTH 14,0 CM	1
AK 077/13	KNAPP DELICATE HOOK SHARP 13,0 CM	1
KA 540/32	MEAD Mallet 320GR MASSIV FERROZ.FAC.17,0 CM	1
KA 800/14	FRIEDMANN RONGEUR FORCEPS 14,0 CM	1
KO 050/01	HARTMANN-HALLE NASAL SPEC.15,0 CM FIG.1	1
KO 275/90	KERRISON ANTRUM RONGEUR FCPS 3X3 MM	1
KO 343/16	JOSEPH SEPTUM ELEVATOR 16,0 CM	1
KO 603/04	FREER CHISELS CURVED 16,0 CM	1
KO 604/04	WEST CHISELS 16,0 CM	1
KO 605/04	WEST GOUGES 16,0 CM	1
KP 114/00	BOWMAN LACRIMAL PROBE POINTED 12,5 CM	1
KP 115/00	BOWMAN LACRIMAL PROBE POINTED 12,5 CM	1
KP 115/12	BOWMAN LACRIMAL PROBE POINTED 12,5 CM	1
KP 115/34	BOWMAN LACRIMAL PROBE POINTED 12,5 CM	1
KP 115/56	BOWMAN LACRIMAL PROBE POINTED 12,5 CM	1
KP 123/14	CASTROVIEJO LACRIMAL DILATOR, 14,0 CM D/E	1
KP 135/14	WORST PIGTAIL PROBE 13,5 CM	1
KP 230/08	STEVENSON LACRIMAL SAC RETRACTOR 7,5 CM	1
KP 700/00	BISHOP-HARMON ANTERIOR CHAMBER	1
KP 740/23	ANEL LACRIMAL CANNULA 23G 4,0 CM	1
KP 741/23	LACRIMAL CANNULA 23G 4,0 CM CURVED	1
SK 305/05	WIRE BASKET, 485 X 255 X 50 MM	1

Sterilization Container KYE 200/61, if required





HARTMANN
AA 114/10
10,0 cm/4"

HARTMANN
AA 115/10
10,0 cm/4"

BACKHAUS
AA 751/08
8,0 cm/3"

GRAEFE
0,5 mm
AB 700/05
7,0 cm/2³/₄"

CASTROVIEJO 1:2
AB 816/01
0,12 mm
10,0 cm/4"

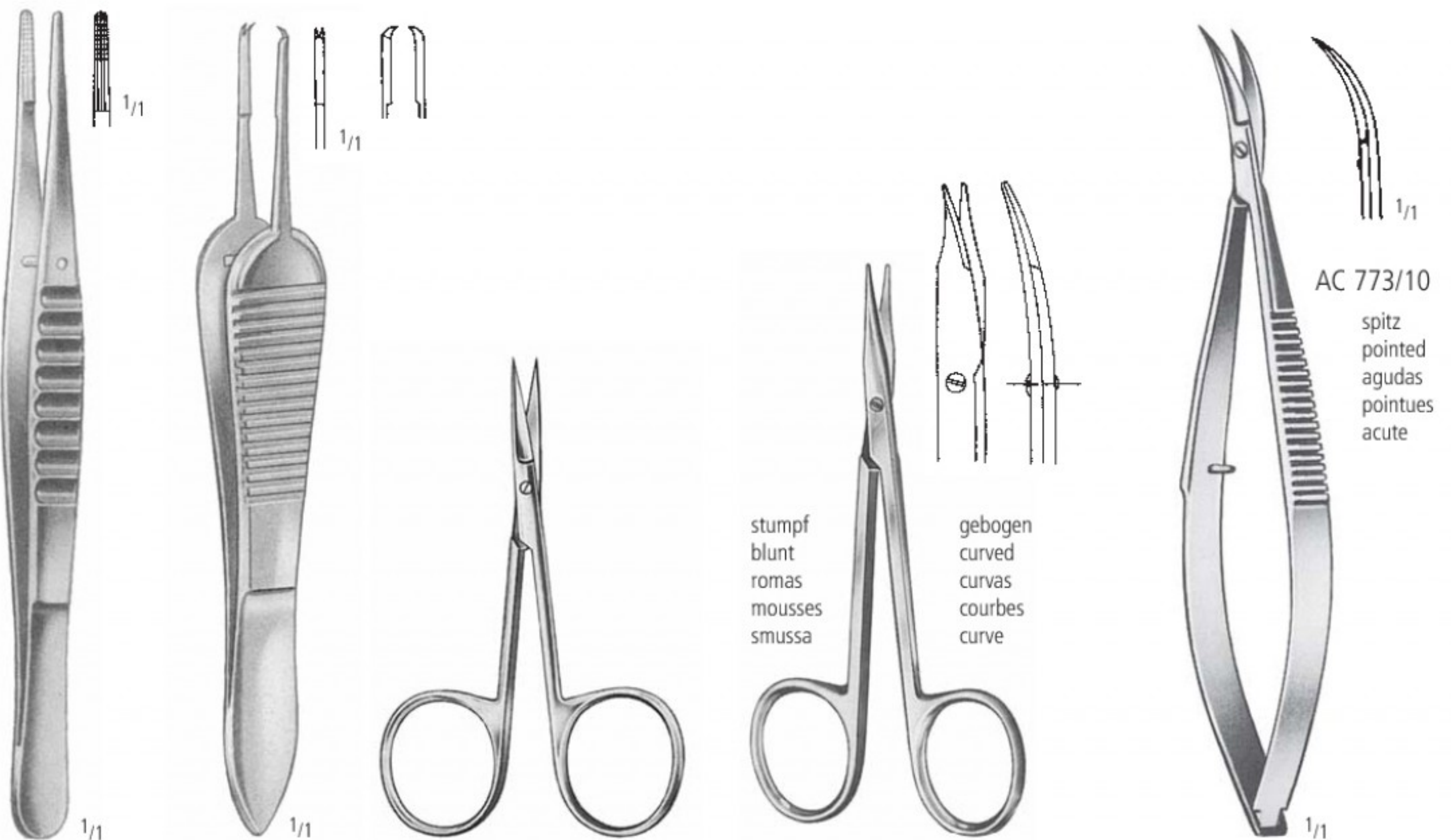

BONACCOLTO
AB 824/02
10,0 cm/4"

PAUFIQUE 1:2
AB 828/10
10,0 cm/4"

AC 466/10
10,0 cm/4"

STEVENS
AC 477/10
10,5 cm/4¹/₄"

CASTROVIEJO
10,0 cm/4"

AC 773/10
spitz
pointed
agudas
pointues
acute

ZS 160/15 DACRYOCYSTORHINOSTOMY D.C.R. LACRIMAL SET

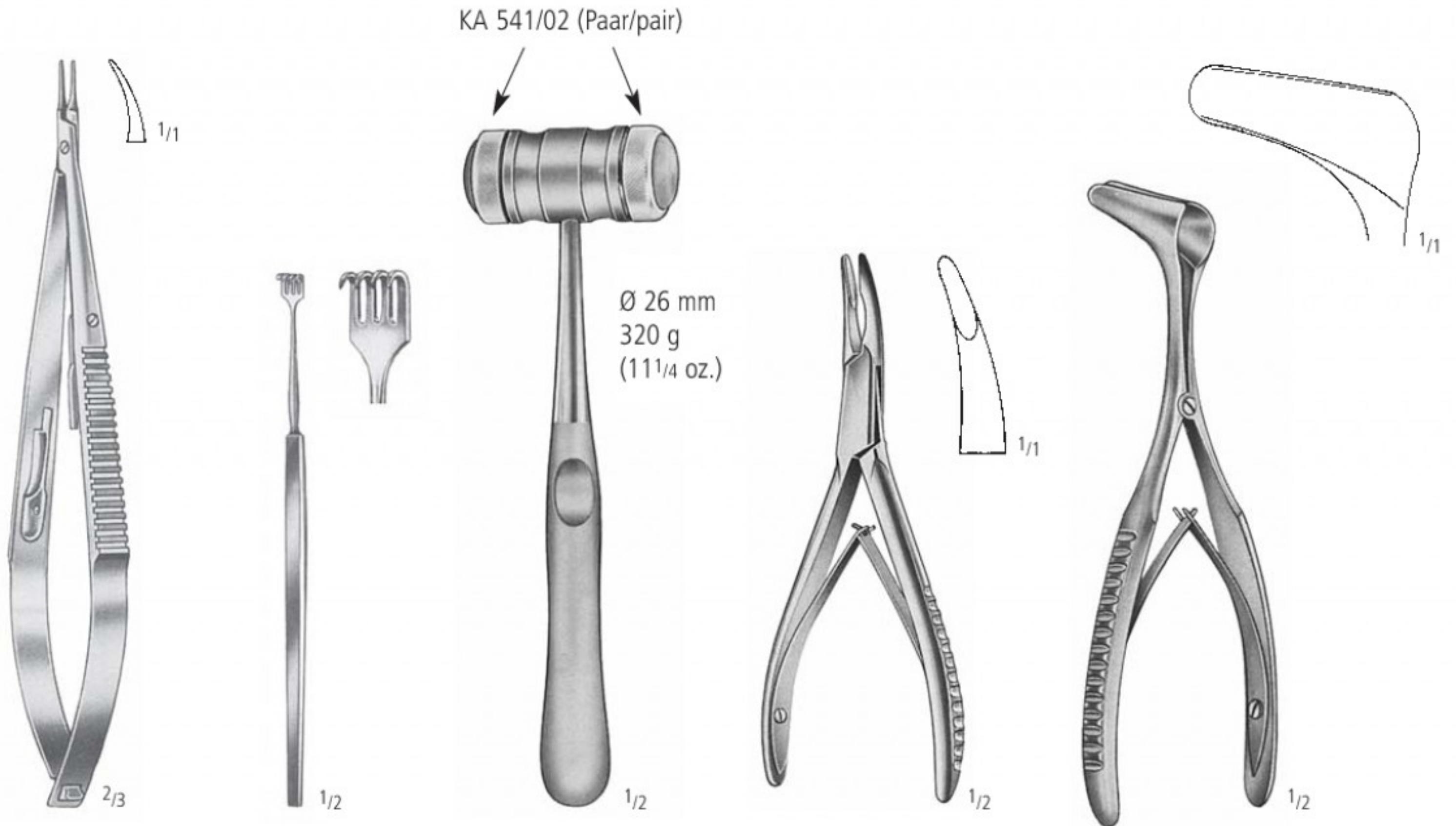

CASTROVIEJO
AE 661/14
14,0 cm/5 1/2"

KNAPP
AK 077/13
13,0 cm/5"

MEAD
KA 540/32
17,0 cm/6 3/4"

FRIEDMAN
KA 800/14
14,0 cm/5 1/2"

HARTMANN-HALLE
KO 050/01
15,0 cm/6"



9,0 cm/3 1/2"
3 x 3 mm
KO 275/90

KERRISON

JOSEPH
KO 343/16
16,0 cm/6 1/4"

FREER
KO 603/04
16,0 cm/6 1/4"

WEST
KO 604/04
16,0 cm/6 1/4"

WEST
KO 605/04
16,0 cm/6 1/4"



geknöpft
pointed
con botón
boutonné
bottenuto

aus Silber
Sterling silver
de plata pura
en argent pur
in argento puro

	Fig.	mm Ø
KP 114/00	0000/00	0,4 / 0,6
KP 115/00	00/0	0,7 / 0,8
KP 115/12	1/2	0,9 / 1,1
KP 115/34	3/4	1,3 / 1,4
KP 115/56	5/6	1,5 / 1,6

BOWMAN
12,5 cm/5"



CASTROVIEJO
KP 123/14
14 cm/5 1/2"

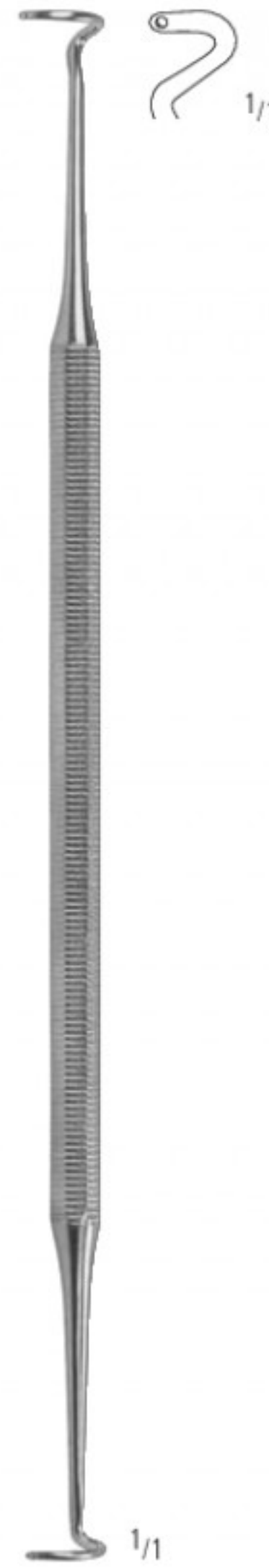

WORST
KP 135/14
13,5 cm/5 1/4"



STEVENSON
KP 230/08
7,5 cm/3"



BISHOP-HARMON
KP 700/00

Set komplett
Set complete
Juego completo
Jeu complet
Set completo

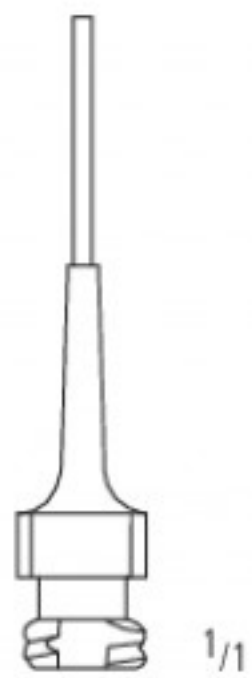

ANEL
KP 740/23
4,0 cm/1 1/2"
23G



KP 741/23
3,5 cm/1 1/2"
23G

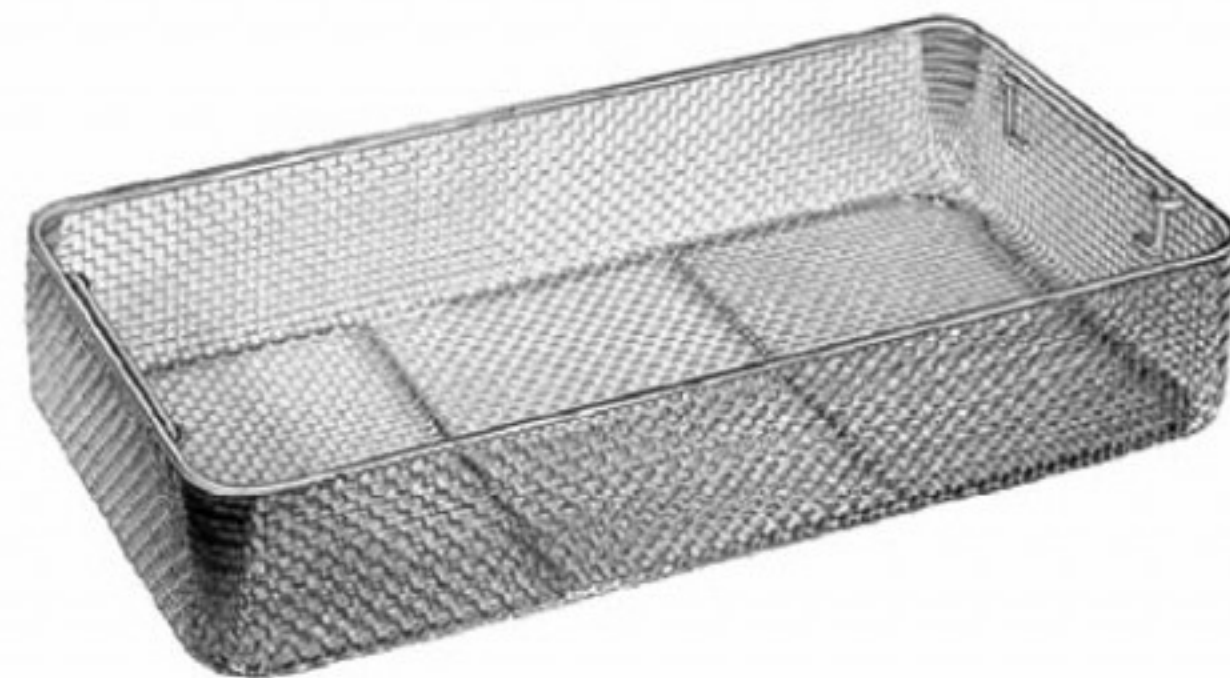

L(mm)	B(mm)	H(mm)	
485	255	50	SK 305/05

ZS 160/20 ENUCLEATION SET

Contents:		Qty
AA 150/14	HALSTED-MOSQUITO ART.FCPS STR 14,0 CM	2
AA 151/14	HALSTED-MOSQUITO ART.FCPS CVD 14,0 CM	2
AA 751/08	BACKHAUS TOWEL FORCEPS 8,0 CM	2
AB 785/01	GRAEFE FIX.FCPS W/O SPRING CATCH 11,0 CM	1
AB 828/10	PAUFIQUE SUTURE FORCEPS 1X2 TEETH 10,0 CM	1
AB 832/01	BLASCOVICS MUSCULAR FORCEPS FIG.1 9,0 CM	1
AC 461/11	STRABISMUS SCISSORS CVD BLUNT 11,5 CM	1
AC 467/10	IRIS SCISSORS CVD W LARGE BOWS 10,0 CM	1
AC 475/11	STEVENS TENOTOM.SCS.CVD POINTED 11,5 CM	1
AE 661/14	CASTROVIEJO NH CVD RA SMOOTH 14,0 CM	1
KP 015/03	GRAEFE STRABISMUS HOOK FIG. 3 15,0 CM	1
KP 200/15	COOK EYE SPECULA 15 MM 5,0 CM	1
KP 400/01	BUNGE EXENTERATION SPOON 14,0 CM 7,0 MM	1
KP 405/15	WELLS ENUCLEATION SPOON LARGE 15,0 CM	1
SK 105/05	WIRE BASKET, 255 X 245 X 50 MM	1

Sterilization Container KYE 200/11, if required



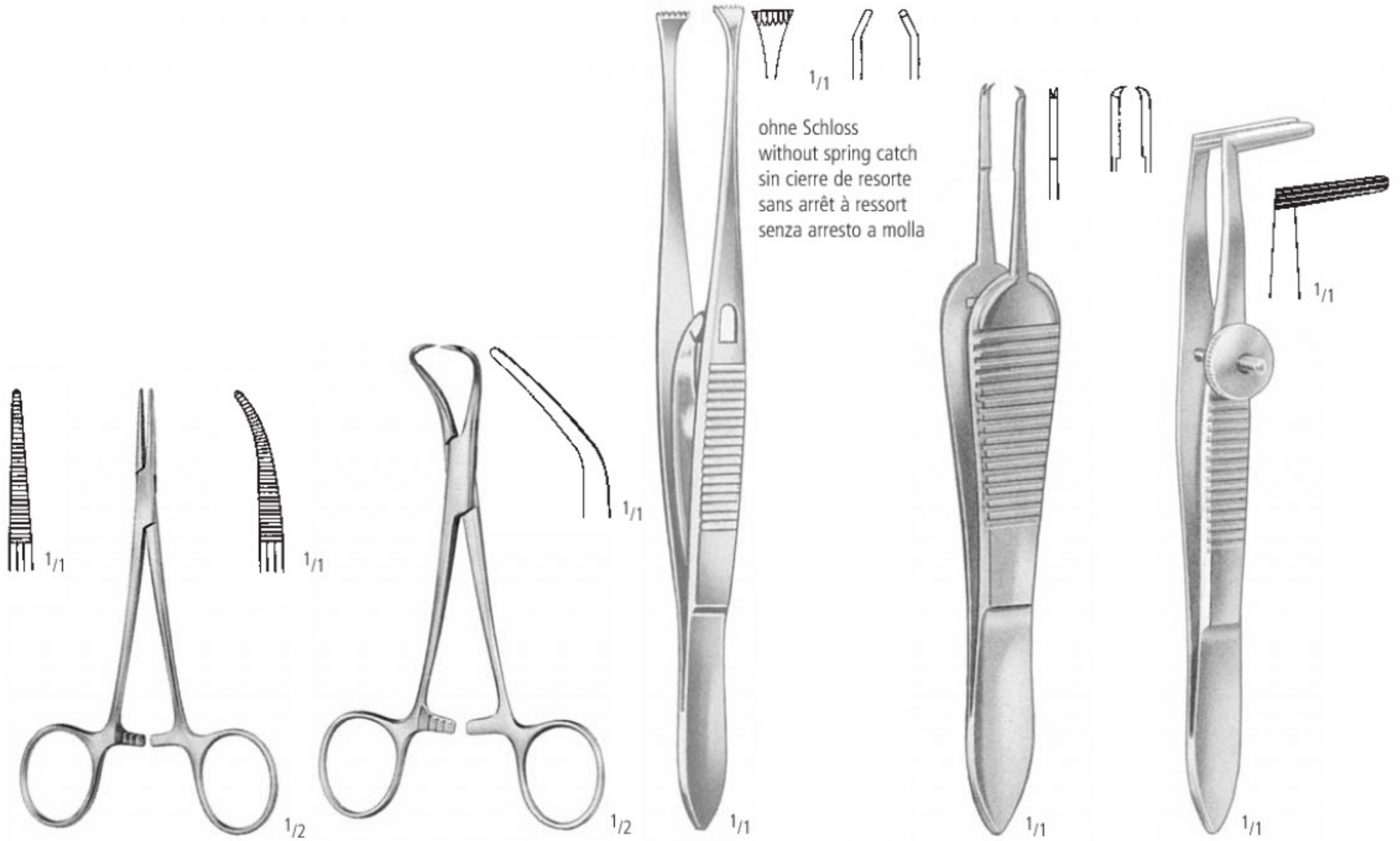

ohne Schloss
without spring catch
sin cierre de resorte
sans arrêt à ressort
senza arresto a molla

HALSTED-MOSQUITO
AA 150/14 AA 151/14
14,0 cm/5¹/₂"

BACKHAUS
AA 751/08
8,0 cm/3"

GRAEFE
AB 785/01
11,0 cm/4¹/₃"

PAUFIQUE 1:2
AB 828/10
10,0 cm/4"

BLASCOVICS
AB 832/01
9,0 cm/3¹/₂"

Strabismusscheren
Strabismus Scissors
Tijeras para estrabismos
Ciseaux à strabisme
Forbici per strabismo

mit großen Ringen
with large bows
con anillos grandes
avec grands anneaux
con anelli grandi

Sehnenscheren
Tenotomy Scissors
Tijeras para tenotomía
Ciseaux à ténotomie
Forbici per tenotomia

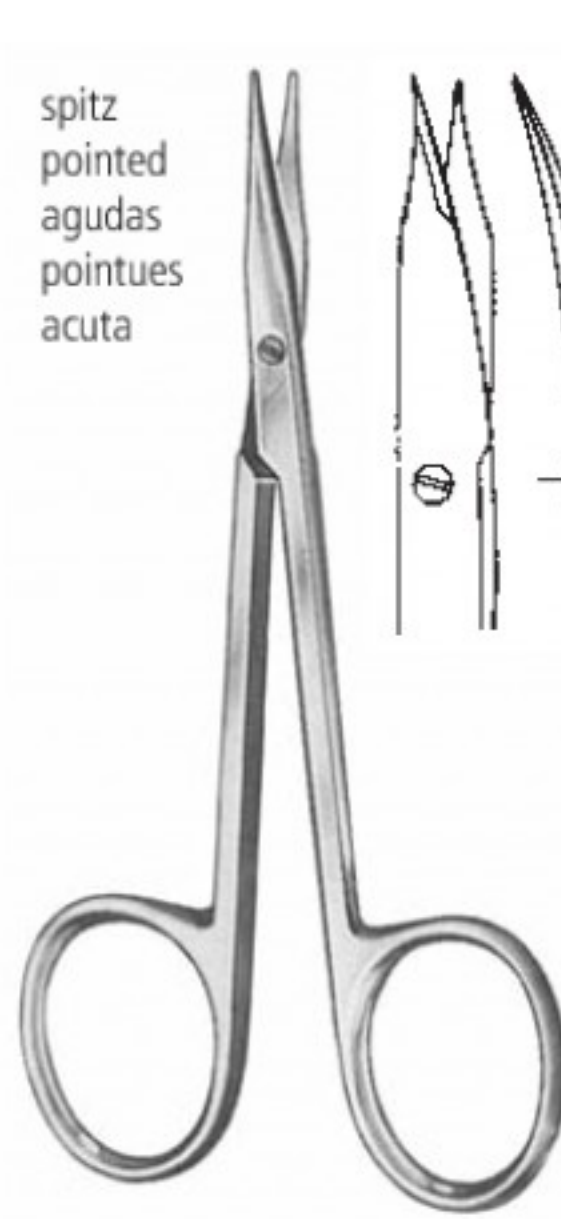
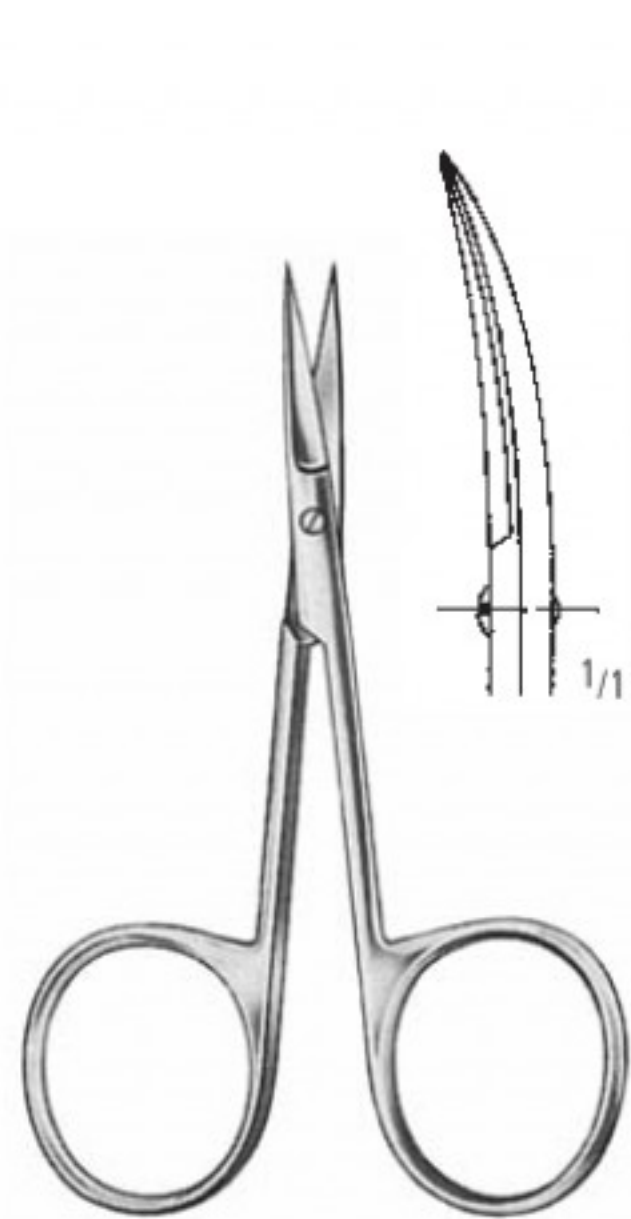

spitz
pointed
agudas
pointues
acuta

gebogen
curved
curvas
courbes
curve

AC 460/11
11,5 cm/4¹/₂"

AC 467/10
10,0 cm/4"

STEVENS
AC 475/11
11,5 cm/4¹/₂"

CASTROVIEJO
AE 661/14
14,0 cm/5¹/₂"

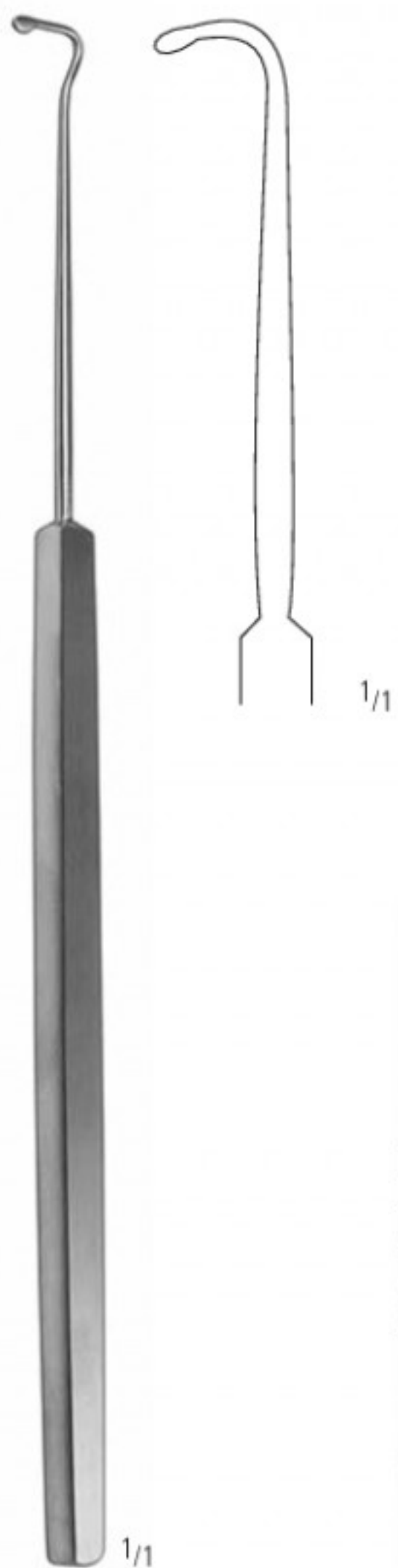

GRAEFE
 KP 015/03
 15,0 cm/6"
 Fig. 3

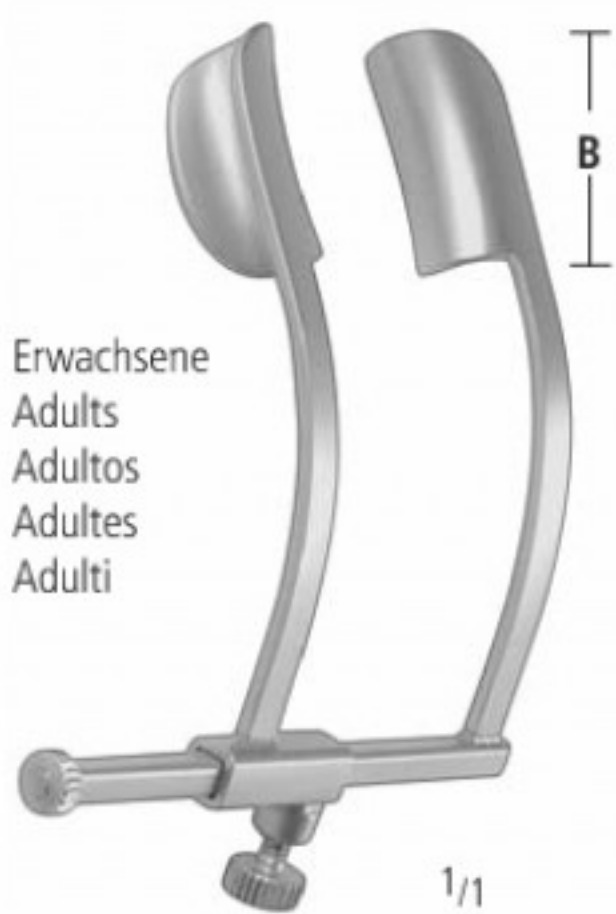

COOK
B
 15 mm
 KP 200/15
 5,0 cm/ 2"



BUNGE
 KP 400/01
 14,0 cm/5 1/2"

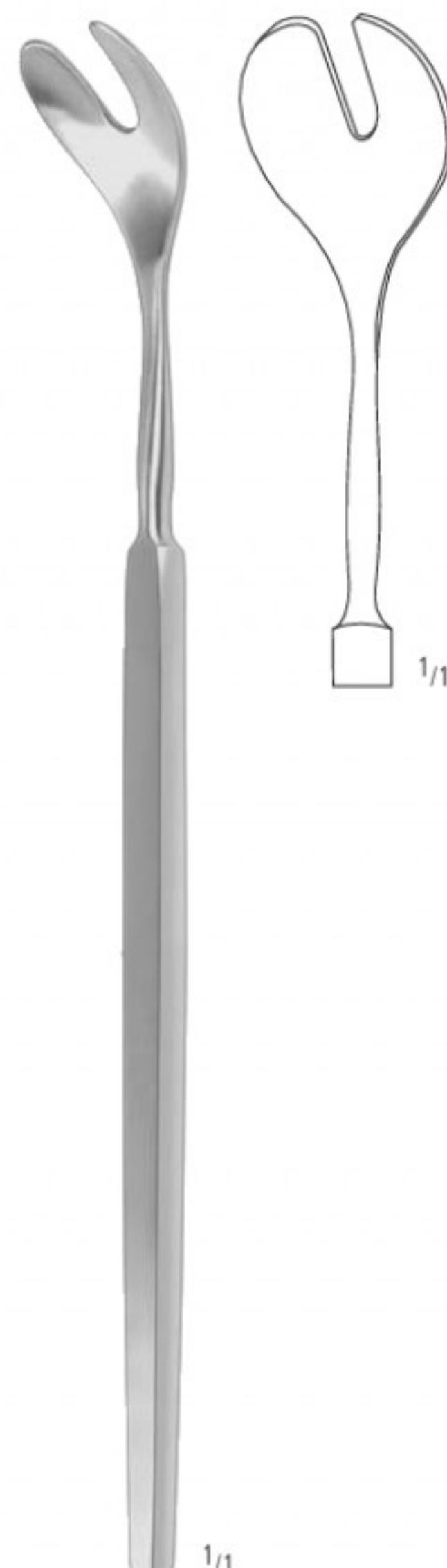

WELLS
 KP 405/15
 15,0 cm/6"



L(mm)	B(mm)	H(mm)	
255	245	50	SK 105/05

ZS 160/25 STITCH REMOVAL SET

Contents:

Qty

AB 750/07	BARRAQUER-KATZIN FIX.FCPS 1X2 T. 7,0 CM	1
AC 779/01	GILLS-WELSH CAPSULOTOMY SCISSORS 8,5 CM	1
KP 150/15	BARRAQUER-COLIBRI EYE SPECULA 15 MM 4,0 CM	1
SX 432/01	SILICON MAT 275X125 MM	1

Sterilization container KYE 351/01, if required

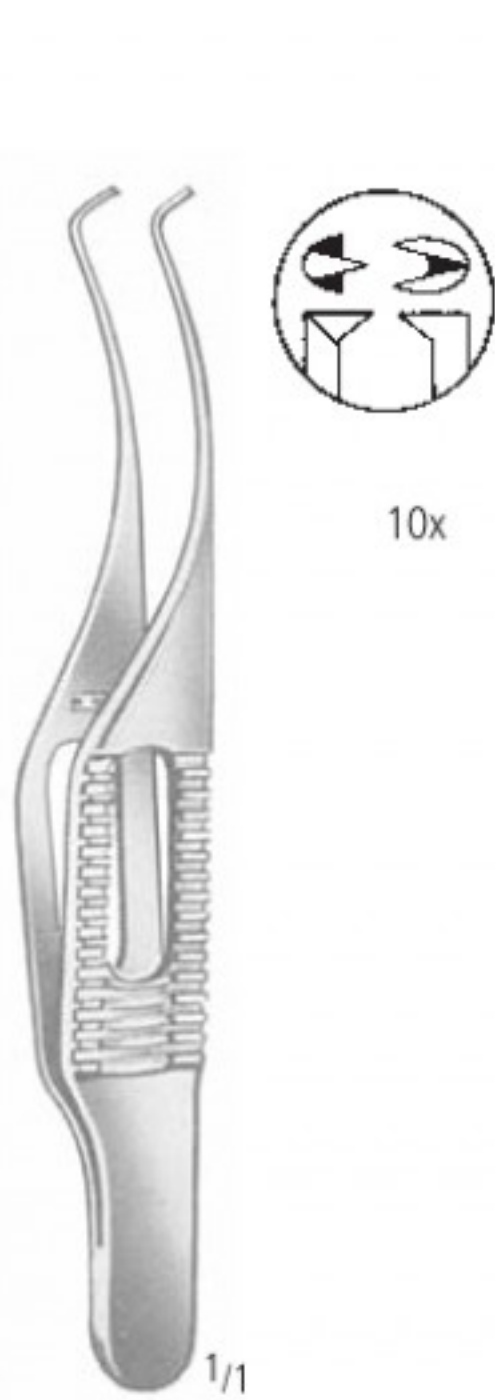

BARRAQUER-KATZIN 1:2
(Colibri)
AB 750/07
7,0 cm/2³/₄"



GILLS-WELSH
AC 779/01
8,5 cm/3¹/₃"

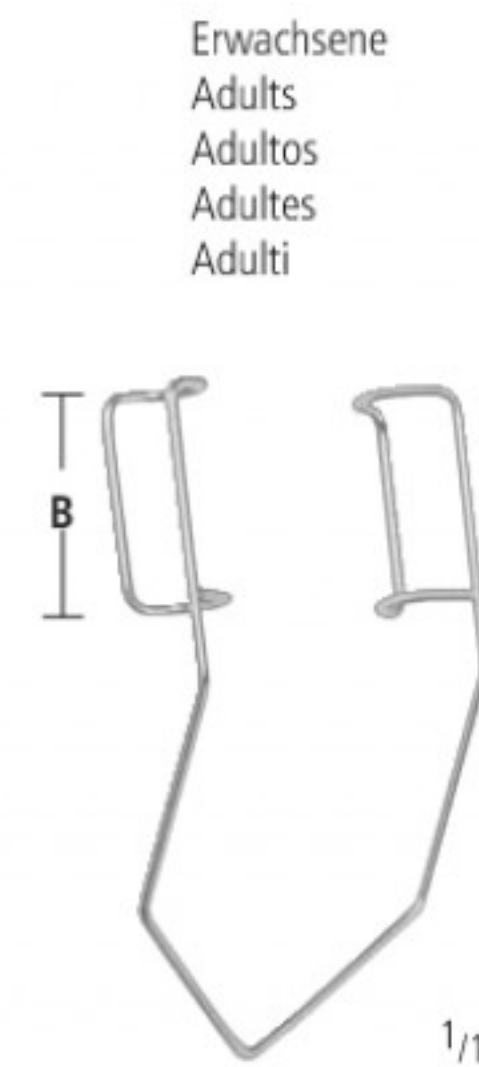

BARRAQUER-COLIBRI
B
15 mm KP 150/15
4,0 cm/1¹/₂"



L(mm)	B(mm)	
275	125	SX 432/01

ZS 160/30 FOREIGN BODY SET

Contents:

KP 150/15	BARRAQUER-COLIBRI EYE SPECULA 15 MM 4,0 CM
KP 350/12	FOREIGN BODY INSTRUMENT
KP 415/10	MEYHOEFER CHALAZION CURETTE
SX 432/01	SILICON MAT 275 X 125 MM

Qty

1
1
1
1

Sterilization container KYE 351/01, if required

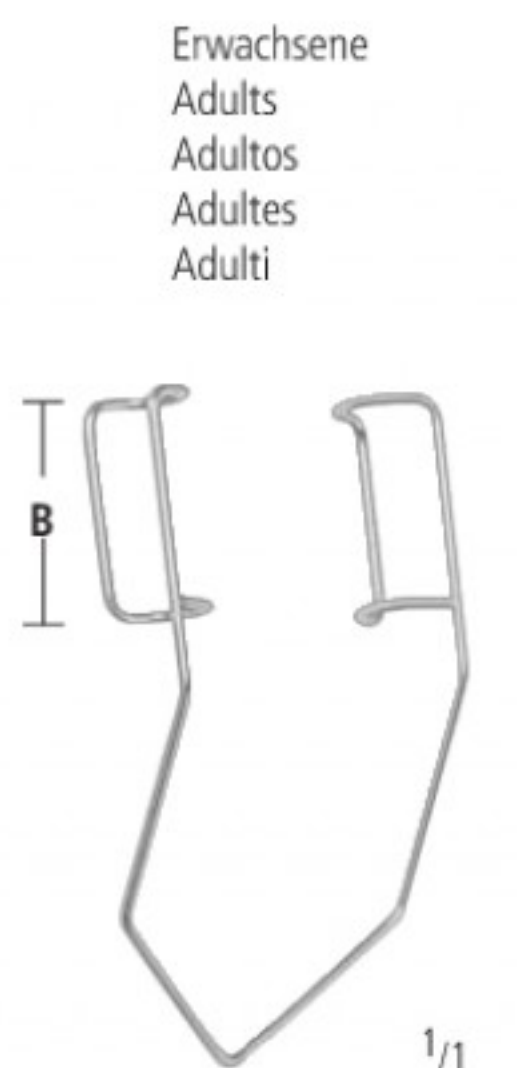

BARRAQUER-COLIBRI
B
15 mm KP 150/15
4,0 cm/1 1/2"

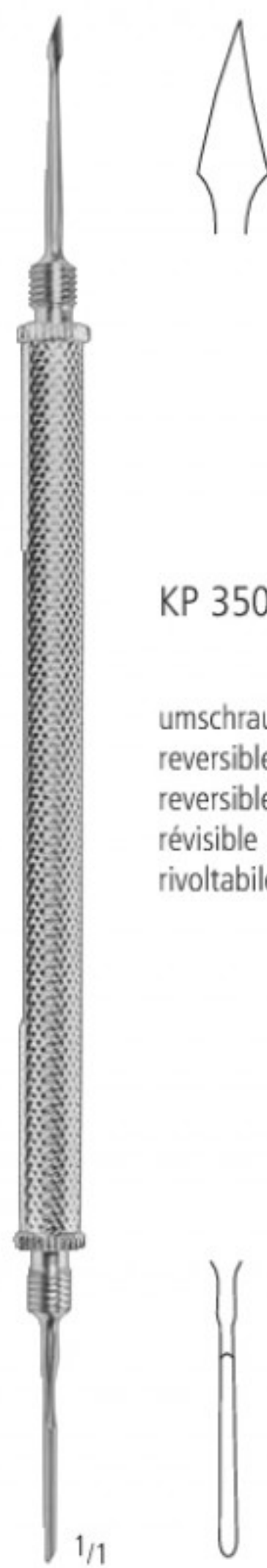

MEYHOEFER
13,0 cm/5"



L(mm)	B(mm)	
275	125	SX 432/01

ZS 160/35 AGLAUCOMA SET

Contents:		Qty
AA 114/10	HARTMANN FORCEPS STR 10,0 CM	1
AA 751/08	BACKHAUS TOWEL FORCEPS 8,0 CM	2
AB 710/10	GRAEFE IRIS FORCEPS STR SERR. 10,0 CM	1
AB 714/10	GRAEFE IRIS FORCEPS STR 1X2 TEETH 10,0 CM	1
AB 734/01	BONN IRIS FORCEPS W.GUIDE PIN 1X2T. 7,0 CM	1
AB 750/07	BARRAQUER-KATZIN FIX.FCPS 1X2 T. 7,0 CM	1
AB 792/11	ELSCHNIG FIXATION FORCPES 1X2 TEETH 11,0 CM	1
AB 825/02	BONN SUTURE FORCEPS 10,0 CM ULRTA FINE	2
AC 431/08	MOD.BONN SCISSORS CVD 8,0 CM	1
AC 768/05	BARRAQUER EYE SCISSORS 5,50 CM 5,0 MM	1
AC 776/02	VANNAS MOD.TÜBINGEN CURVED 8,5 CM	1
AC 782/11	WESTCOTT TENOTOMY SCISSORS BLUNT 11,0 CM	1
AE 605/11	BARRAQUER MICRO-NEEDLE HOLDER CVD 10,0 CM	1
AE 660/14	CASTROVIEJO NH STR RA SMOOTH 14,0 CM	1
AR 282/20	CASTROVIEJO CIRCLE 8,0 CM STRAIGHT	1
KP 130/01	HARMS TRABECULAR PROBE RIGHT 4,5 CM	1
KP 130/02	HARMS TRABECULAR PROBE LEFT 4,5 CM	1
KP 161/05	CORCELLE EYE SPECULA 8 MM, 5,0 CM	1
KP 373/01	PREMIUM DIAMOND KNIFE ANGLED SPEER 1,4 CM	1
KP 376/01	PREMIUM DIAMOND KNIFE 1,0 CM 45° 7 STEPS	1
KP 478/12	MOD.DORTMUND PHACO SPATULA 12,0 CM	1
KP 543/01	SCHIOETZ TONOMETER INCLINED SCALE	1
KP 611/00	ELLIOT TREPHINE HANDLE ONLY 3,0 CM	1
KP 612/10	ELLIOT SCLERAL TREPHINE Ø 1,0 MM	1
KP 700/00	BISHOP-HARMON ANTERIOR CHAMBER	1
KP 712/27	MCINTYRE ANTERIOR CHAMBER CANNULA 27G	2
KP 731/27	SAUTTER AIR INJECTION CANNULA 27G 3,5 CM	2
SK 305/05	WIRE BASKET, 485 X 255 X 50 MM	1

Sterilization Container KYE 200/61, if required



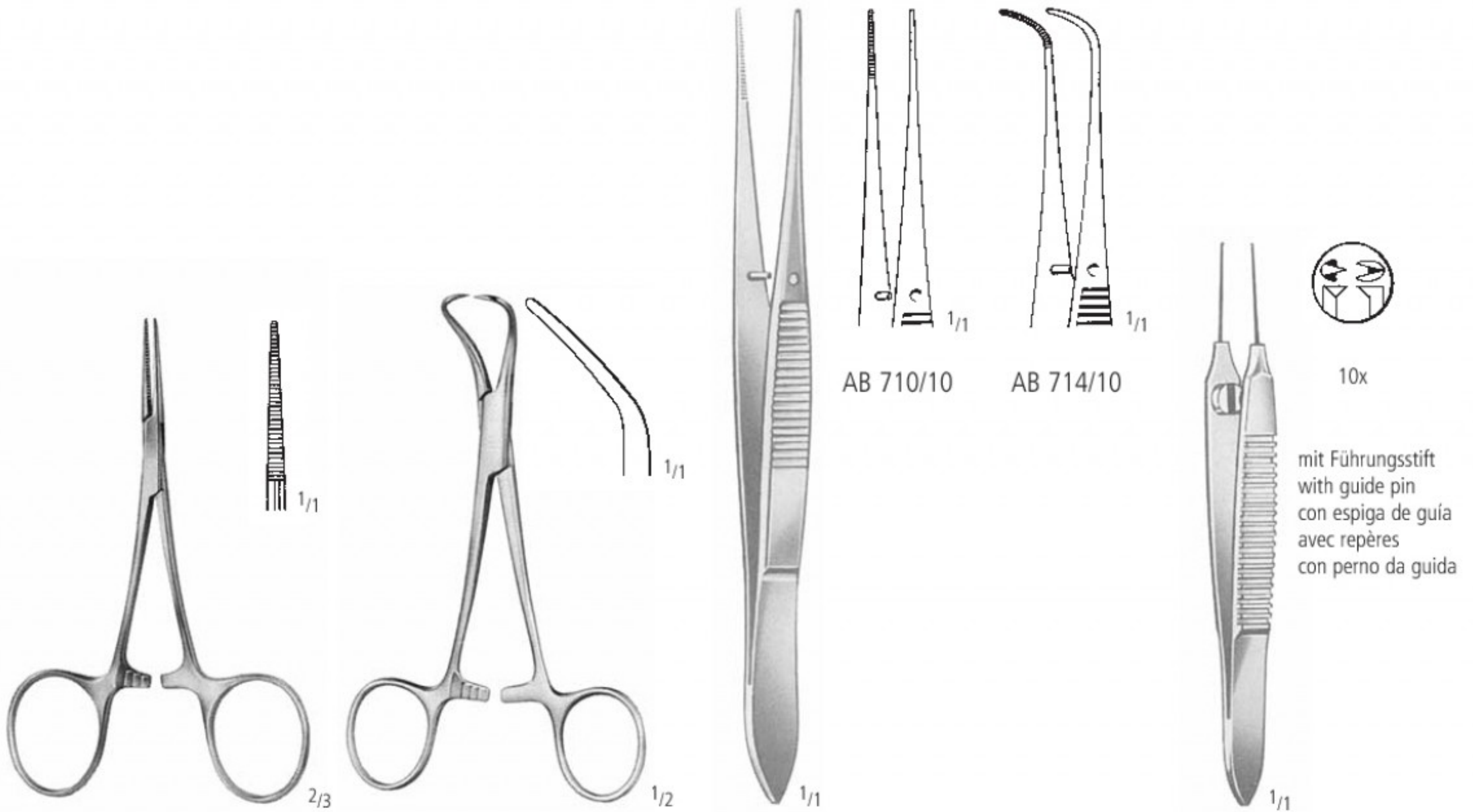

HARTMANN
AA 114/10
10,0 cm/4"

BACKHAUS
AA 751/08
8,0 cm/3"

GRAEFE
10,0 cm/4"

MOD. BONN 1:2
AB 734/01
7,0 cm/2³/₄"



BARRAQUER-KATZIN 1:2 (Colibri)
AB 750/07
7,0 cm/2³/₄"

ELSCHNIG 1:2
AB 792/11
11,0 cm/4¹/₃"

MOD. BONN
AB 825/02
10,0 cm/4"

MOD. BONN
AC 431/08
8,0 cm/3"

BARRAQUER
5 mm AC 768/05
5,5 cm/2¹/₄"

ZS 160/35 AGLAUCOMA SET

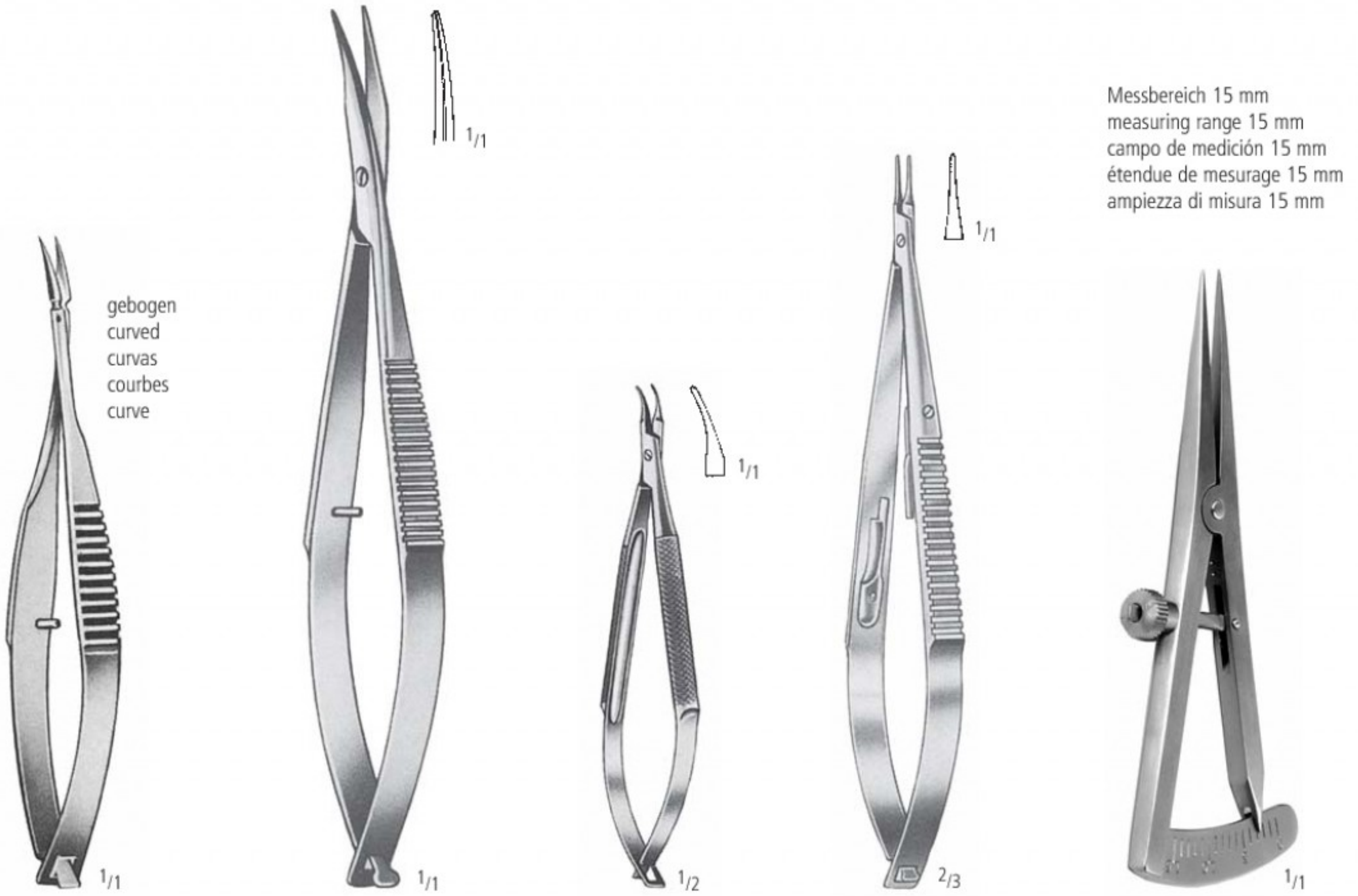

VANNAS MOD. TÜBINGEN
AC 776/02
8,5 cm/3¹/₃"

WESTCOTT
AC 782/11
11,0 cm/4¹/₃"

BARRAQUER
AE 605/13
13,0 cm/5"

CASTROVIEJO
AE 660/14
14,0 cm/5¹/₂"

CASTROVIEJO
AR 282/15
8,0 cm/ 3"

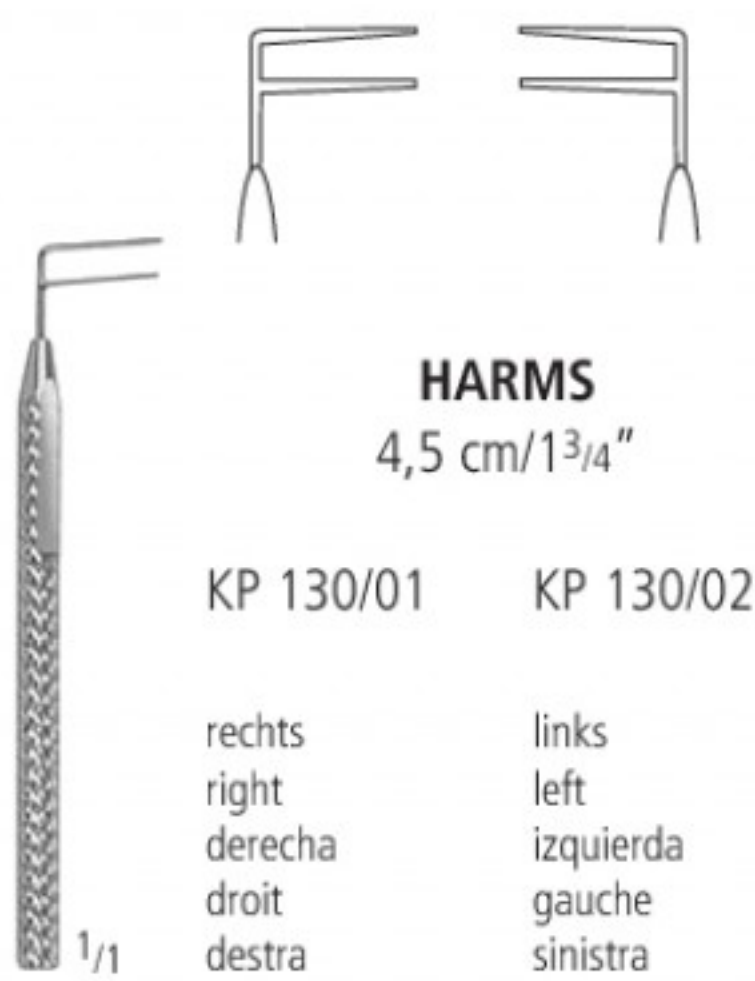

HARMS
4,5 cm/1³/₄"

KP 130/01 KP 130/02

rechts
right
derecha
droit
destra

links
left
izquierda
gauche
sinistra

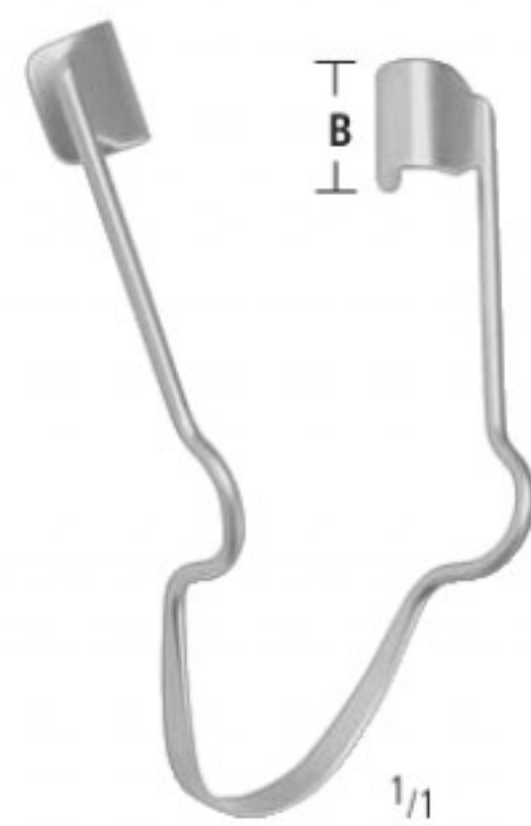

CORCELLE
KP 161/05
5,0 cm/ 2"
B = 8 mm

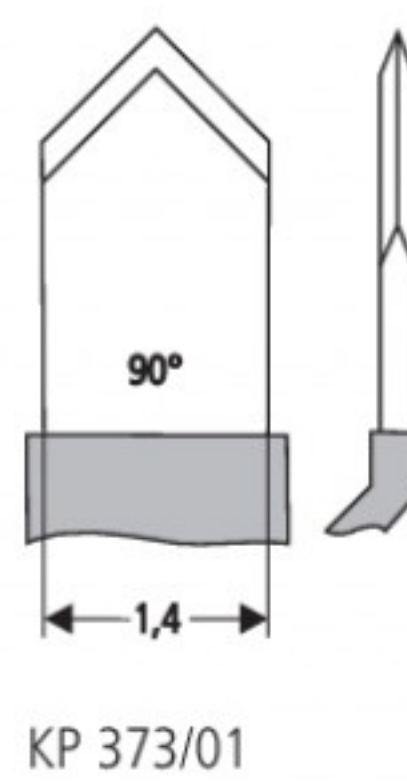

7 Stufen:
7 steps:
7 escalones:
7 étages:
7 gradi:
0 / 0,3 / 0,4 / 0,5 / 0,6 / 0,8 / 1,0 / 2,5 mm



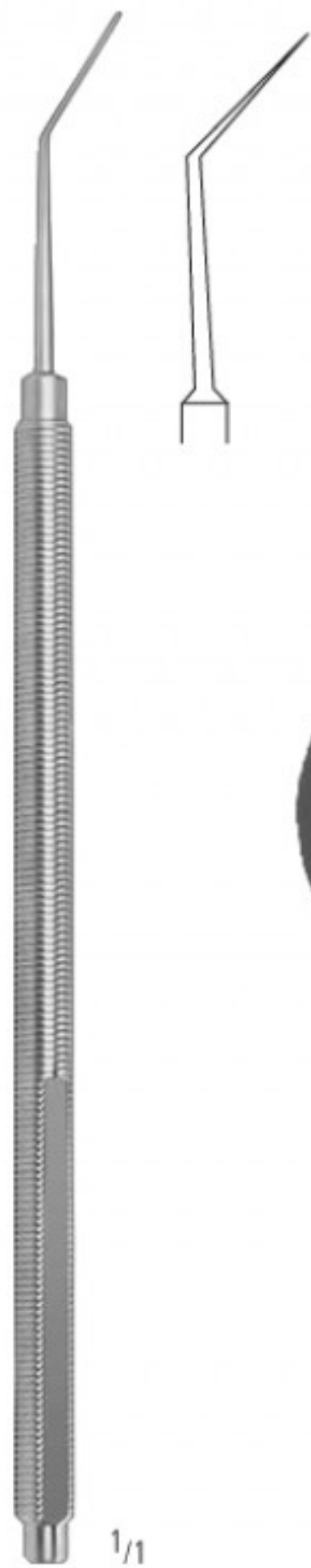

MOD. DORTMUND
 KP 478/12
 12,0 cm/ 4³/₄"
 0,6 x 12 mm



schräge Skala
 inclined scale
 graduado inclinado
 échelle oblique
 scala inclinata

SCHIOETZ
 KP 543/01
 13,0 cm/5"

Spezifikation Nr. 5, geeicht
 Specification No. 5, calibrated
 Especificación No. 5, calibrada
 Spécification No. 5, calibrée
 Specifica No. 5, calibrata



ELLIOT
 KP 611/00
 3,0 cm/1¹/₄"



ELLIOT
 KP 612/10
 Ø 1,0 mm



Set komplett
 Set complete
 Juego completo
 Jeu complet
 Set completo

BISHOP-HARMON
 KP 700/00



McINTYRE
 2,5 cm/1"
 KP 712/27
 27G

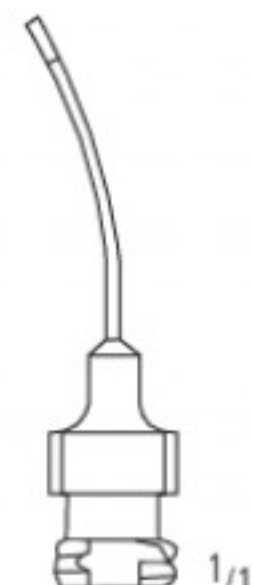

SAUTTER
 KP 731/27
 3,5 cm/1¹/₂"
 27G

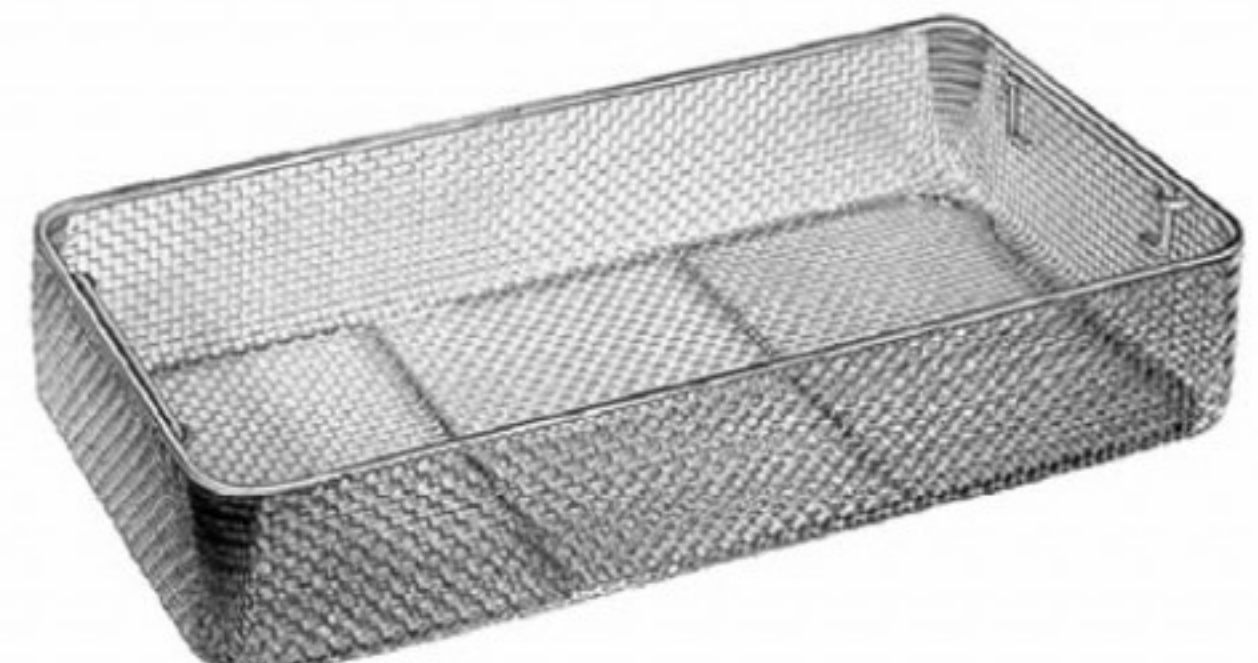

L(mm)	B(mm)	H(mm)	
485	255	50	SK 305/05

ZS 160/40 CATARACT E.C. SET

Contents:		Qty
AA 060/05	DIEFFENBACH BULLDOG CLAMPS STR 5,0 CM	2
AA 114/10	HARTMANN FORCEPS STR 10,0 CM	1
AA 751/08	BACKHAUS TOWEL FORCEPS 8,0 CM	2
AB 714/10	GRAEFE IRIS FORCEPS STR 1X2 TEETH 10,0 CM	1
AB 735/02	BONN MICRO IRIS FORCEPS ANGLED 7,0 CM	1
AB 750/07	BARRAQUER-KATZIN FIX.FCPS 1X2 T. 7,0 CM	1
AB 768/01	ARRUGA CAPSULAR FCPS NOT CALIBR. 10,0 CM	1
AB 792/11	ELSCHNIG FIXATION FORCPES 1X2 TEETH 11,0 CM	1
AB 819/02	MCPHERSON TYING FORCEPS ANGLED 10,5 CM	1
AB 825/02	BONN SUTURE FORCEPS 10,0 CM ULRTA FINE	1
AB 848/11	FAULKNER LENS HOLDING FORCEPS 11,0 CM	1
AC 431/08	MOD.BONN SCISSORS CVD 8,0 CM	1
AC 768/10	BARRAQUER EYE SCISSORS 5,5 CM 10 MM	1
AC 776/03	VANNAS MOD.TÜBINGEN ANGLED 8,5 CM	1
AC 778/02	VANNAS SEC.CATARACT SCISSORS,CVD. 8,0 CM	1
AC 782/11	WESTCOTT TENOTOMY SCISSORS BLUNT 11,0 CM	1
AC 785/01	CASTROVIEJO DELICATE EYE SCS. 10,0 CM RI.	1
AC 785/02	CASTROVIEJO DELICATE EYE SCS. 10,0 CM LE.	1
AC 797/02	WESTCOTT STRABISMUS SCS CVD SHARP 11,5 CM	1
AD 075/11	PCK=100 BLADES FIG.11	1
AD 554/13	BLADE BREAKER 13.0 CM DIA 8,0 MM	1
AE 603/10	BARRAQUER-TROUTMAN MICRO-NH CVD 10,0 CM	1
AE 660/14	CASTROVIEJO NH STR RA SMOOTH 14,0 CM	1
AE 688/14	KALT MICRO-NEEDLE HOLDER STR 14,0 CM	1
AR 282/20	CASTROVIEJO CIRCLE 8,0 CM STRAIGHT	1
KP 030/13	HIRSCHMANN IRIS HOOK 12,5 CM 45°	1
KP 071/25	SINSKEY LENS MANIPULATOR 12,0 CM	1
KP 154/04	BARRAQUER PHACO EYE SPECULA 4,0 CM	1
KP 440/13	SNELLEN LENS SCOOP SERRATED 13,0 CM	1
KP 478/12	MOD.DORTMUND PHACO SPATULA 12,0 CM	1
KP 545/02	MALONEY KERATOMETER INTRAOPERATIVE 2,0 CM	1
KP 700/00	BISHOP-HARMON ANTERIOR CHAMBER	1
KP 712/27	MCINTYRE ANTERIOR CHAMBER CANNULA 27G	1
KP 720/23	SIMCOE IRRIGATION AND ASPIRATION CANNULA	1
KP 731/27	SAUTTER AIR INJECTION CANNULA 27G 3,5 C	2
KP 755/23	KNOLLE-PEARCE LENS LOOP WITH IRRIGATION	1
KP 767/27	JENSEN CAPSULE POLISHER 27G DIAMOND	1
SK 305/05	WIRE BASKET, 485 X 255 X 50 MM	1

Sterilization Container KYE 200/61, if required



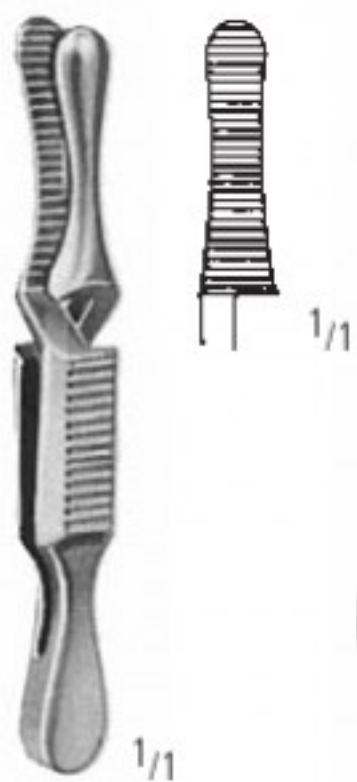

DIEFFENBACH
AA 060/05
5,0 cm/2"

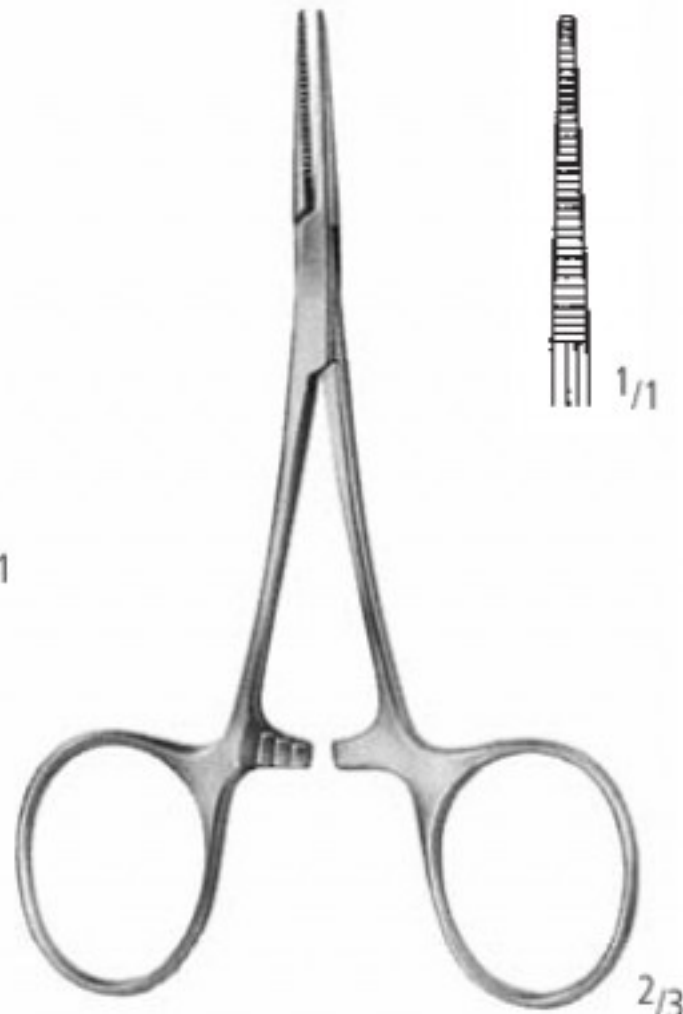

HARTMANN
AA 114/10
10,0 cm/4"

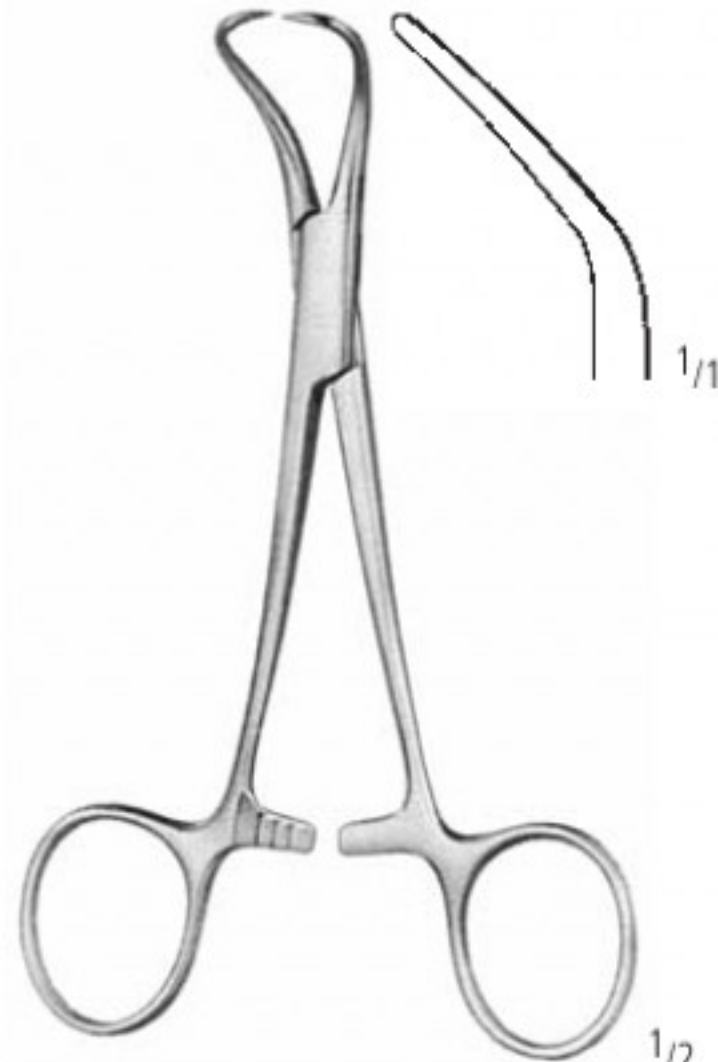

BACKHAUS
AA 751/08
8,0 cm/3"

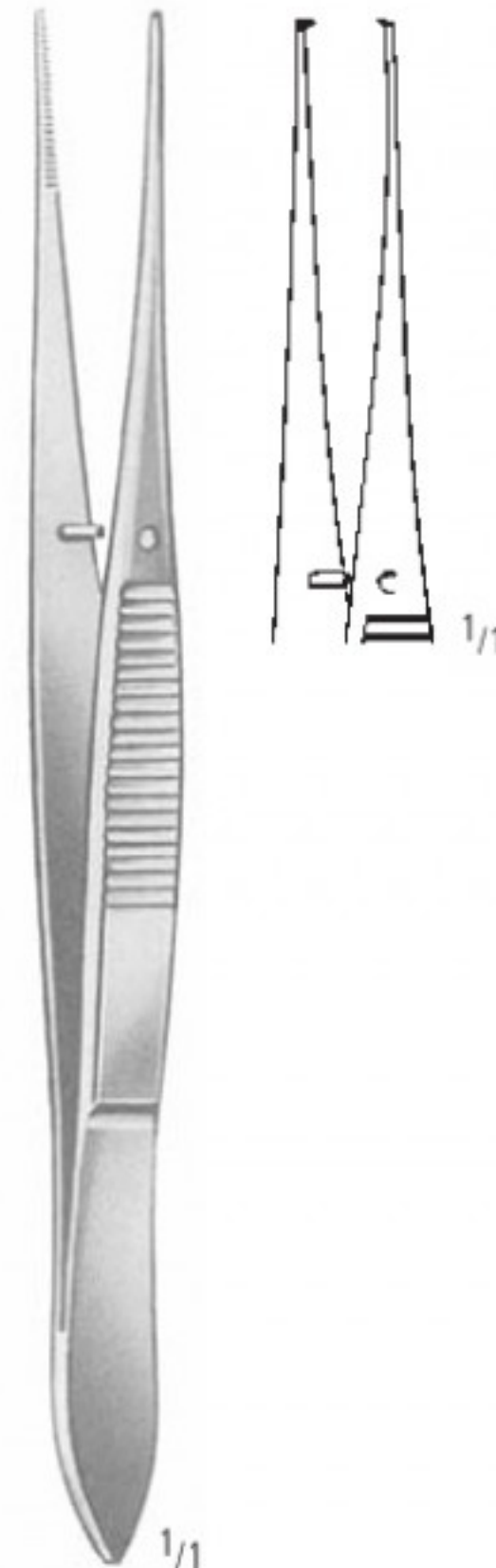

GRAEFE
AB 714/10
10,0 cm/4"



MOD. BONN
AB 735/02
7,0 cm/2³/₄"



BARRAQUER-KATZIN 1:2 (Colibri)
AB 750/07
7,0 cm/2³/₄"



ungeeicht
not calibrated
non calibrada
non calibrée
non calibrata

ARRUGA
AB 768/01
10,0 cm/4"



ELSCHNIG 1:2
AB 792/11
11,0 cm/4¹/₃"



McPHERSON
AB 819/02
10,0 cm/4"



MOD. BONN
AB 825/02
10,0 cm/4"



FAULKNER
AB 848/11
11,0 cm/4¹/₃"

sehr fein
extra delicate
muy finas
très fin
molto sottile

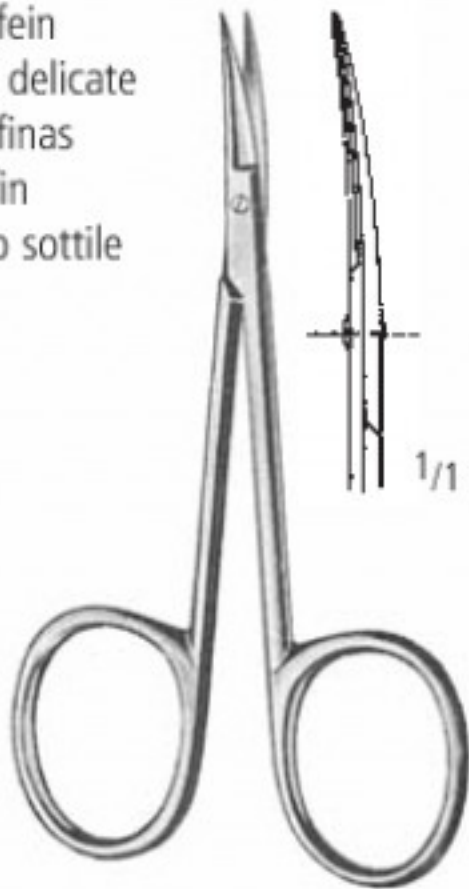

MOD. BONN
AC 431/08
8,0 cm/3"

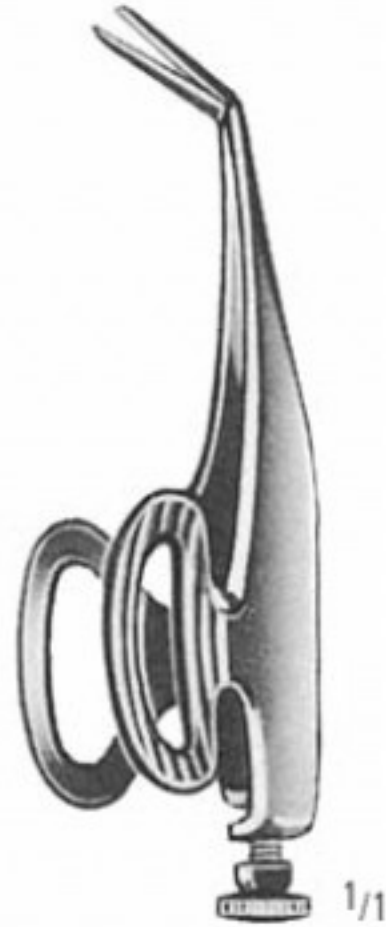

BARRAQUER
5,5 cm/2 1/4"
10 mm AC 768/10

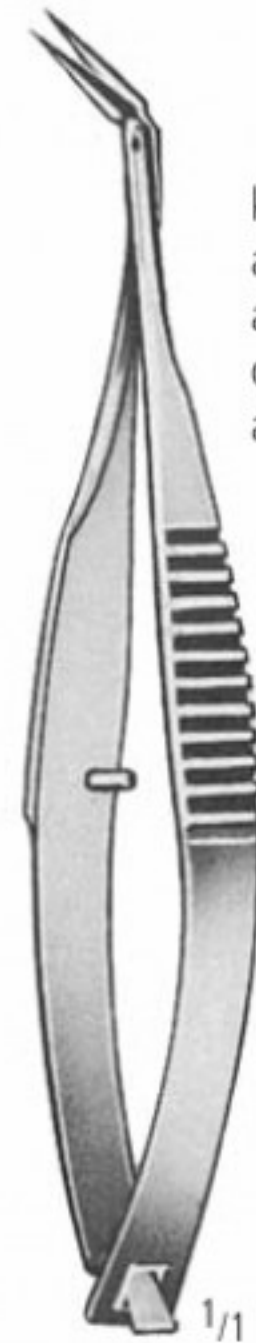

kniegebogen
angular
acodadas
coudés
angolato

VANNAS MOD. TÜBINGEN
AC 776/03
8,5 cm/3 1/3"

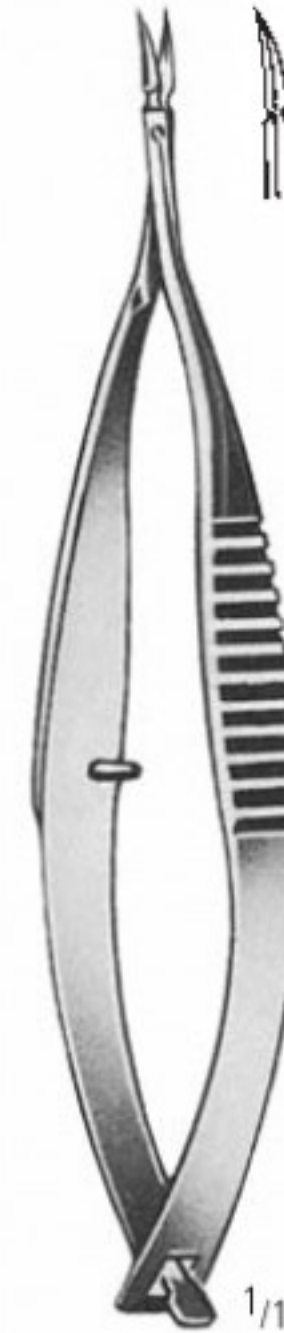

gebogen
curved
curvas
courbes
curve

VANNAS
AC 778/02
8,0 cm/3"

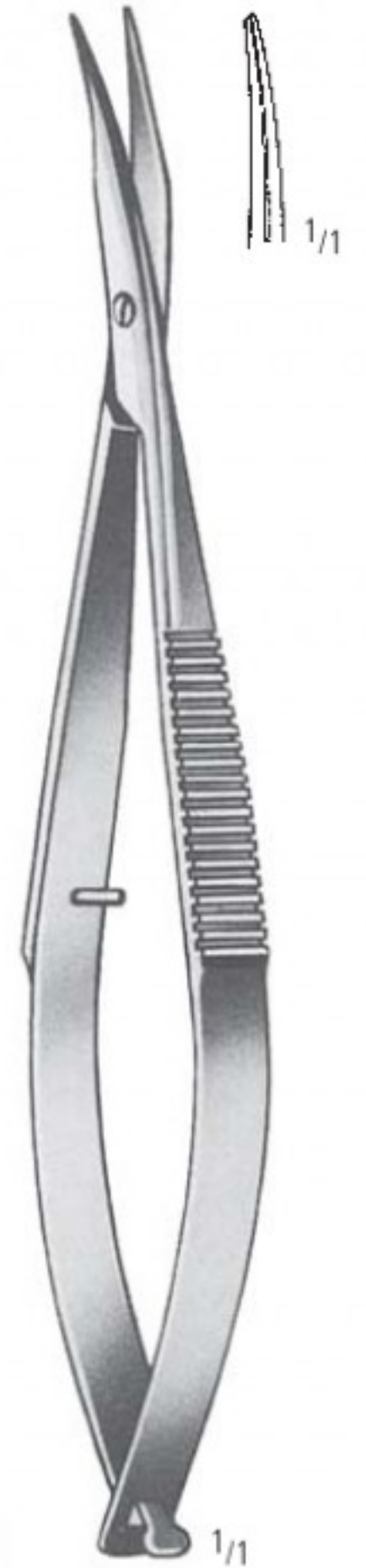

WESTCOTT
AC 782/11
11,0 cm/4 1/3"



CASTROVIEJO
AC 785/01
10,0 cm/4"

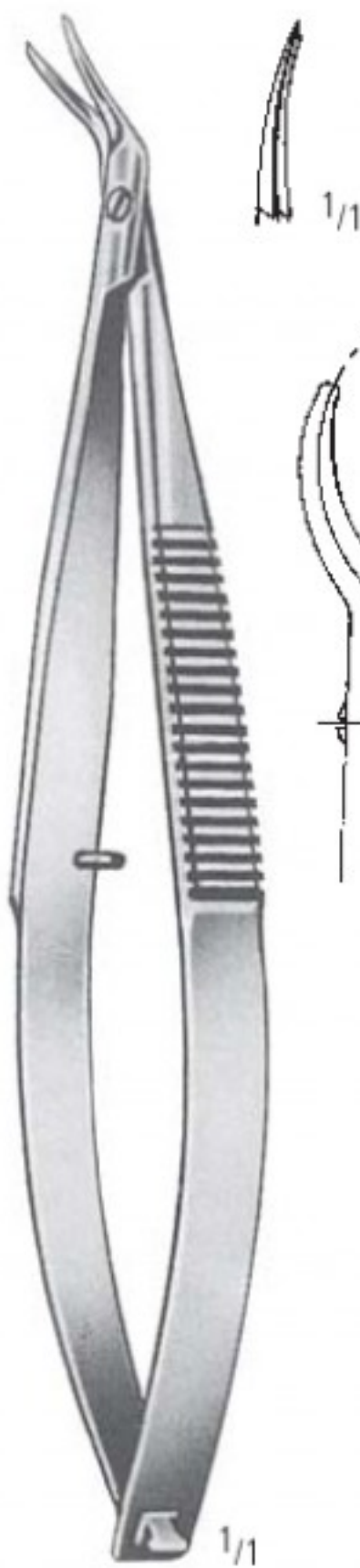

CASTROVIEJO
AC 785/02
10,0 cm/4"

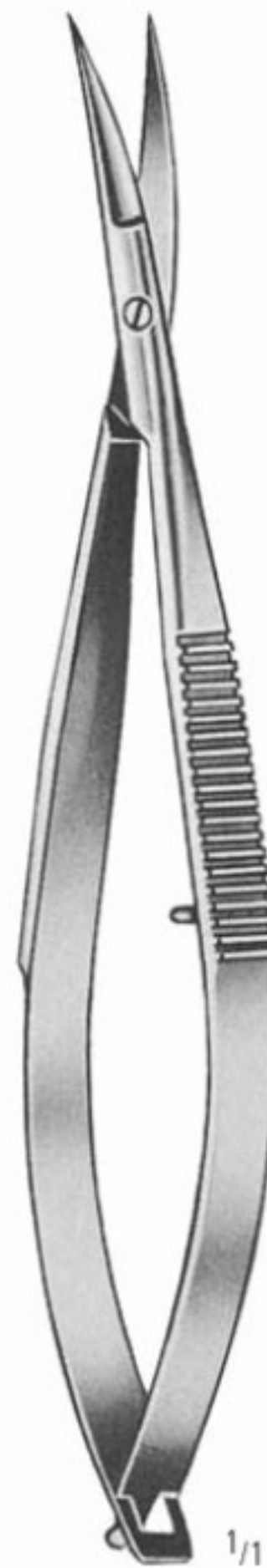

WESTCOTT
AC 797/02
11,5 cm/4 1/2"



Fig. 11
AD 075/11

steril
sterile
estériles
stériles
sterili



CASTROVIEJO
AD 554/13
Ø 8 mm
13,0 cm/5"

Messbereich 20 mm
measuring range 20 mm
campo de medición 20 mm
étendue de mesurage 20 mm
ampiezza di misura 20 mm



**BARRAQUER-
TROUTMAN**
AE 603/10
10,0 cm/4"



CASTROVIEJO
AE 660/14
14,0 cm/5 1/2"



KALT
AE 688/14
14,0 cm/5 1/2"



CASTROVIEJO
AR 282/20
8,0 cm/ 3"

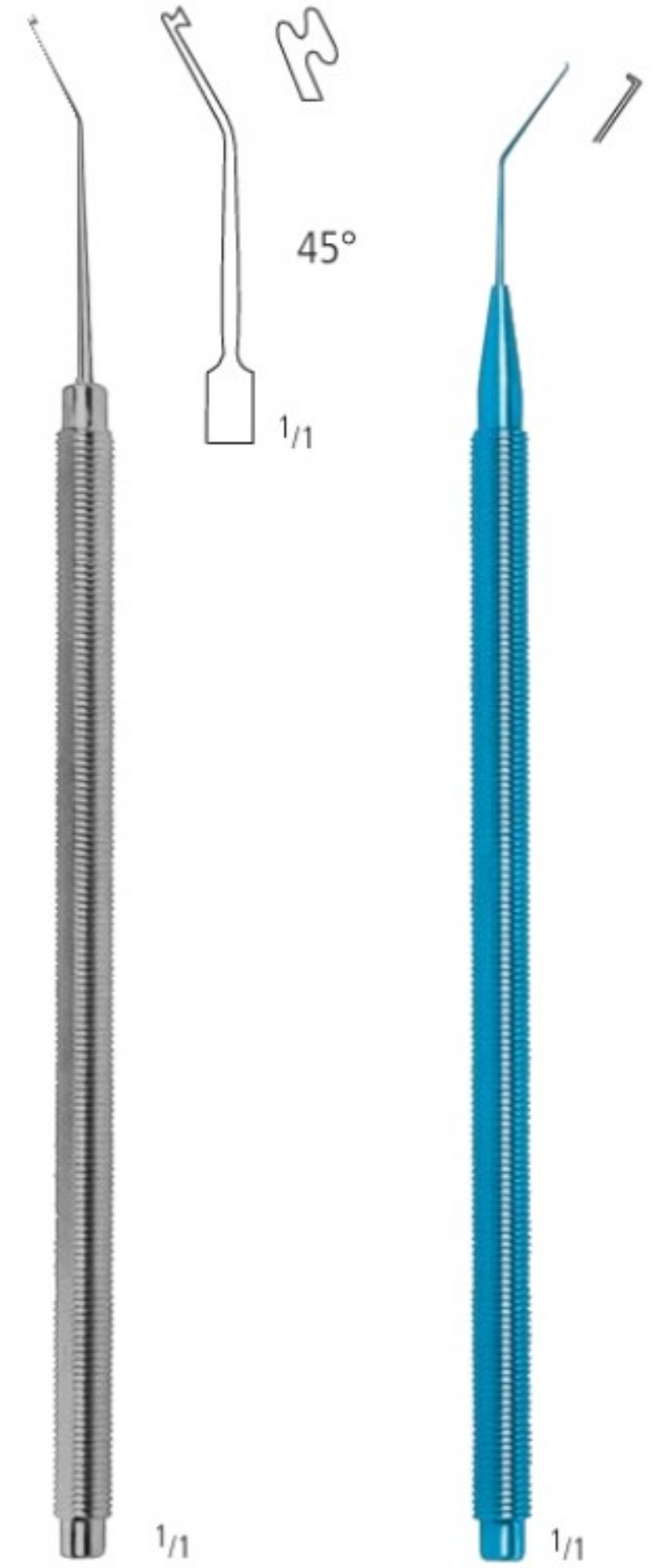

HIRSCHMANN
KP 030/13
12,5 cm/5"

SINSKEY
KP 071/25
Ø 0,25 mm
12,0 cm/4 3/4"



BARRAQUER PHAKO
KP 154/04
4,0 cm/1 1/2"



SNELLEN
KP 440/13
13,0 cm/5"

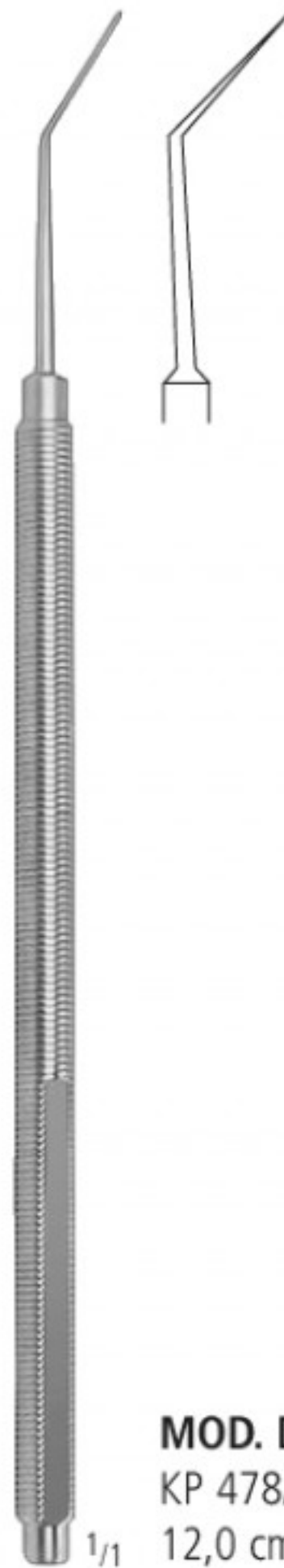

MOD. DORTMUND
KP 478/12
12,0 cm/ 4 3/4"
0,6 x 12 mm



MALONEY
KP 545/02
2,0 cm/ 3/4"



BISHOP-HARMON
KP 700/00

Set komplett
Set complete
Juego completo
Jeu complet
Set completo

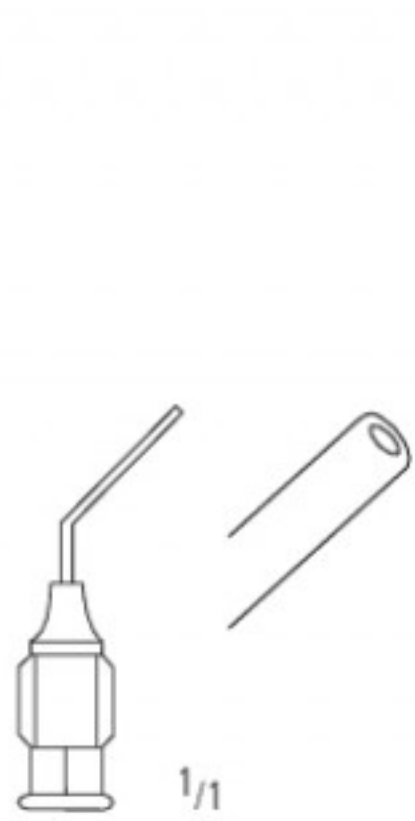

McINTYRE
2,5 cm/1"
KP 712/27
27G



SIMCOE
KP 720/23
3,0 cm/1 1/4"
25/23G

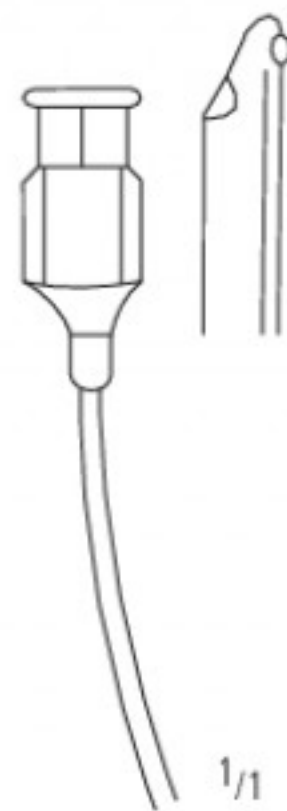

SAUTTER
KP 731/27
3,5 cm/1 1/2"
27G

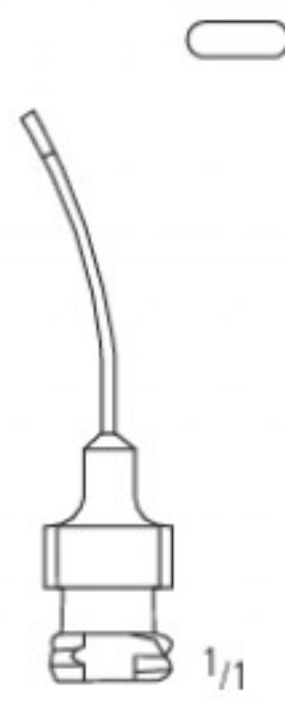

KNOLLE-PEARCE
KP 755/23
5,0 cm/2"
23G

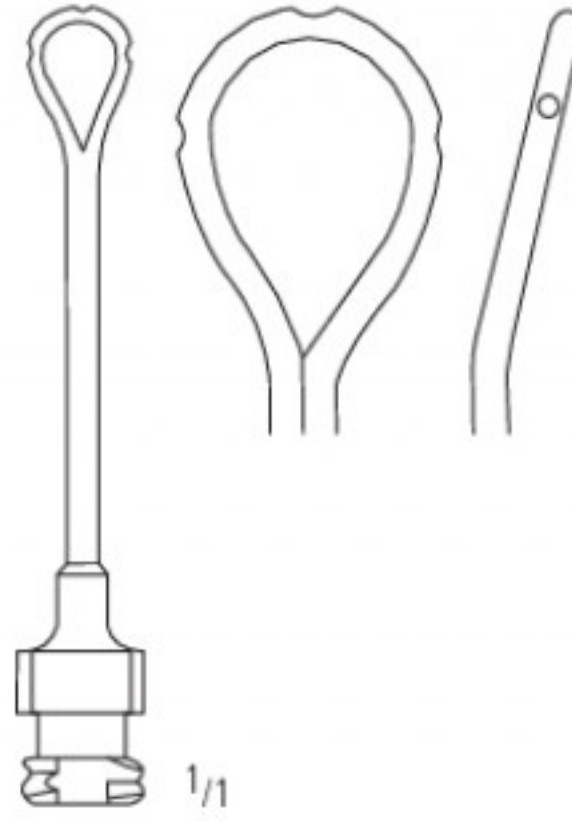

JENSEN
KP 767/27
4,5 cm/2"
27G

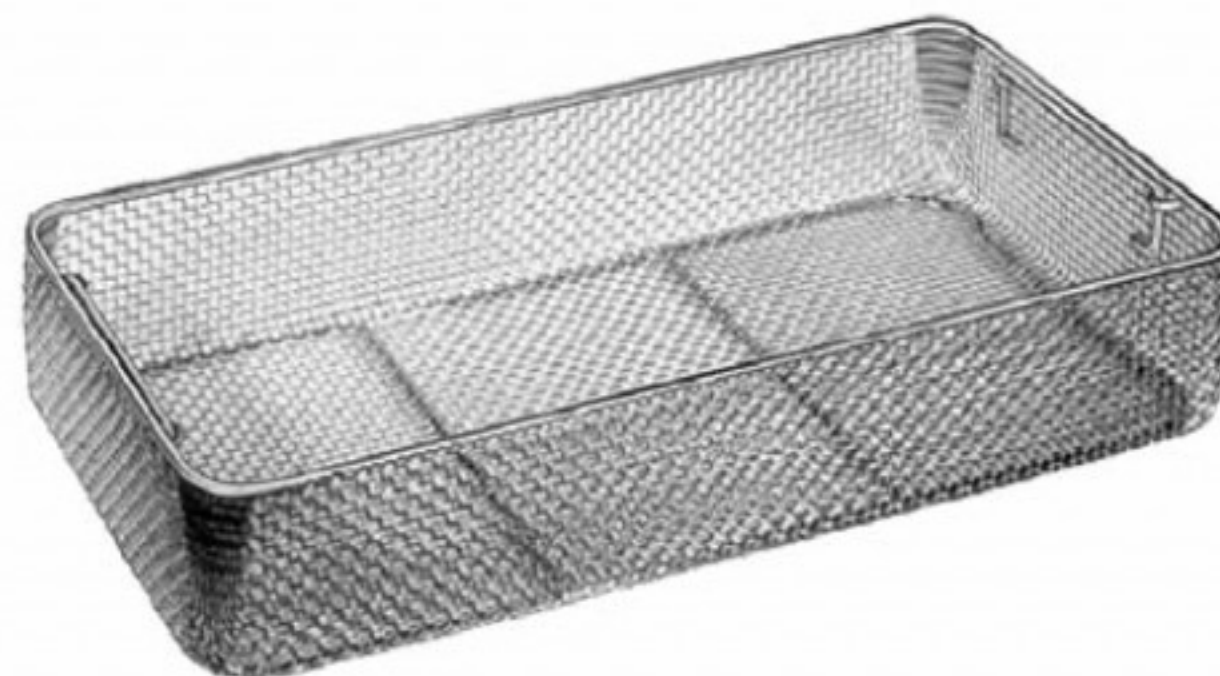

L(mm)	B(mm)	H(mm)	
485	255	50	SK 305/05

ZS 160/45 CATARACT PHACOEMULSIFICATION SET

Contents:		Qty
AA 060/05	DIEFFENBACH BULLDOG CLAMPS STR 5,0 CM	2
AA 150/14	HALSTED-MOSQUITO ART.FCPS STR 14,0 CM	1
AA 751/15	BACKHAUS TOWEL FORCEPS 15,0 CM	2
AB 714/10	GRAEFE IRIS FORCEPS STR 1X2 TEETH 10,0 CM	1
AB 750/07	BARRAQUER-KATZIN FIX.FCPS 1X2 T. 7,0 CM	1
AB 767/02	CASTROVIEJO CAPSULAR FCPS CROSSED 10,0 CM	1
AB 768/01	ARRUGA CAPSULAR FCPS NOT CALIBR. 10,0 CM	1
AB 792/11	ELSCHNIG FIXATION FORCPES 1X2 TEETH 11,0 CM	1
AB 819/02	MCPHERSON TYING FORCEPS ANGLED 10,5 CM	1
AB 825/02	BONN SUTURE FORCEPS 10,0 CM ULRTA FINE	1
AB 848/11	FAULKNER LENS HOLDING FORCEPS 11,0 CM	2
AB 852/02	MCDONALD IOL CAPSULORHEXIS FORCEPS 10,0 CM	1
AC 431/08	MOD.BONN SCISSORS CVD 8,0 CM	1
AC 776/04	VANNAS MOD.TÜBINGEN ANGLED O.FL. 8,5 CM	1
AC 778/03	VANNAS SEC.CATARACT SCISSORS,ANGULAR, 8,0 CM	1
AC 782/11	WESTCOTT TENOTOMY SCISSORS BLUNT 11,0 CM	1
AD 075/11	PCK=100 BLADES FIG.11	1
AD 550/09	BLADE BREAKER 9.0 CM DIA 5,5 MM	1
AD 551/09	BLADE BREAKER CVD 9.0 CM DIA 5,5 MM	1
AE 605/14	BARRAQUER MICRO-NEEDLE HOLDER CVD 14,0 CM	1
AE 660/14	CASTROVIEJO NH STR RA SMOOTH 14,0 CM	1
AE 688/14	KALT MICRO-NEEDLE HOLDER STR 14,0 CM	1
AR 282/20	CASTROVIEJO CIRCLE 8,0 CM STRAIGHT	1
KP 030/13	HIRSCHMANN IRIS HOOK 12,5 CM 45°	1
KP 040/02	JAFFE-BECHERT LENS NUCLEUS ROTATOR 12,0 CM	1
KP 067/60	NAGAHARA PHACO SPLITTER 12,0 CM 60°	1
KP 071/25	SINSKEY LENS MANIPULATOR 12,0 CM	1
KP 154/04	BARRAQUER PHACO EYE SPECULA 4,0 CM	1
KP 210/02	LIEBERMAN EYE SPECULA 15 MM K-SHAPE 8,0 CM	1
KP 335/12	MOD. HAMBURG KERATOME 12,0 CM	1
KP 370/04	PREMIUM DIAMOND KNIFE ANGLED LANCE 1,4 CM	1
KP 371/01	PREMIUM DIAMOND KNIFE STR.TRI-FACET 1,0 CM	1
KP 371/02	PREMIUM DIAMOND KNIFE ANGLED 2,0 CM	1
KP 545/02	MALONEY KERATOMETER INTRAOPERATIVE 2,0 CM	1
KP 550/12	THORNTON FIXATION RING FG-HINGE Ø13,0 MM	1
KP 700/00	BISHOP-HARMON ANTERIOR CHAMBER	1
KP 712/27	MCINTYRE ANTERIOR CHAMBER CANNULA 27G	1
KP 731/27	SAUTTER AIR INJECTION CANNULA 27G 3,5 CM	1
KP 767/27	JENSEN CAPSULE POLISHER 27G DIAMOND	2
SK 305/05	WIRE BASKET, 485 X 255 X 50 MM	1

Sterilization Container KYE 200/61, if required



ZS 160/45 CATARACT PHACOEMULSIFICATION SET



DIEFFENBACH
AA 060/05
5,0 cm/2"

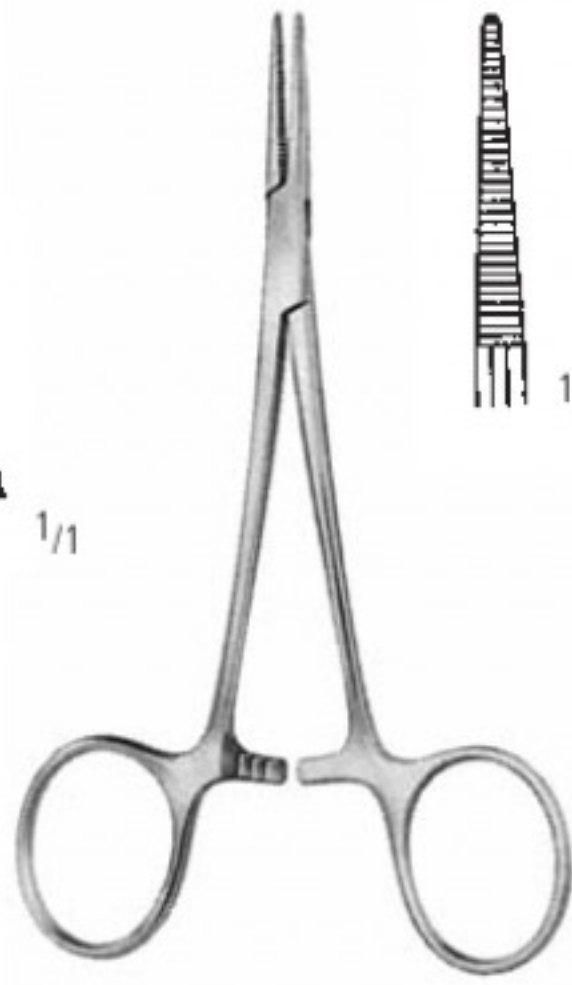
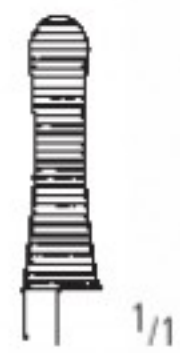

HALSTED-MOSQUITO
AA 150/14
14,0 cm/5¹/₂"

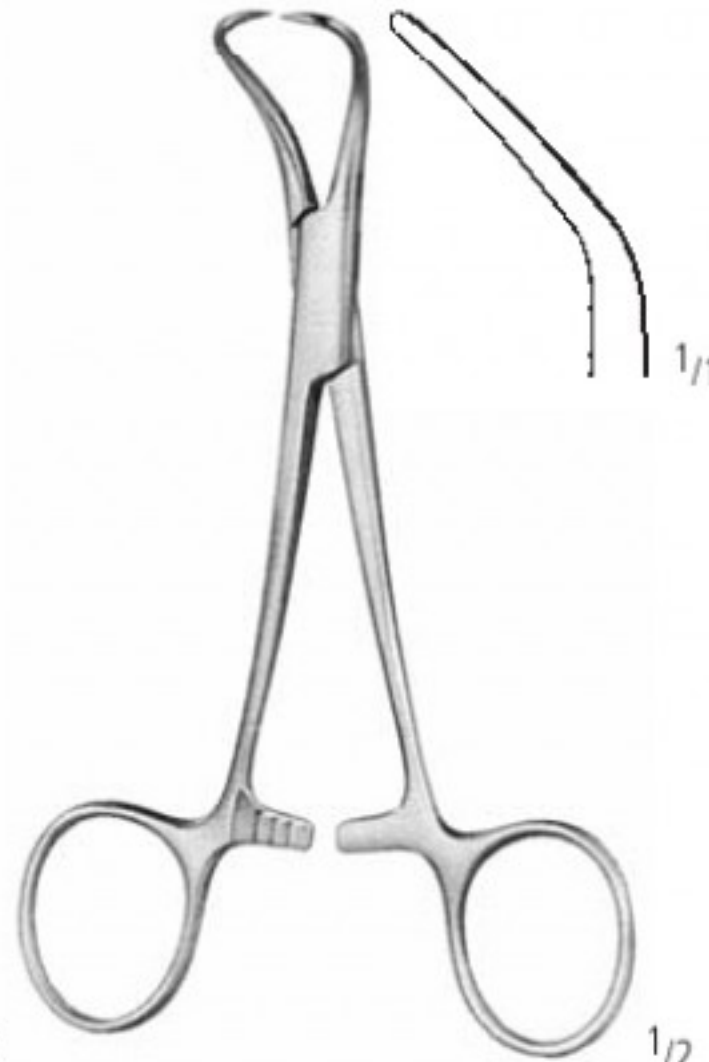

BACKHAUS
AA 751/15
15,0 cm/6"



GRAEFE
AB 714/10
10,0 cm/4"



BARRAQUER-KATZIN 1:2 (Colibri)
AB 750/07
7,0 cm/2³/₄"



10x



CASTROVIEJO
AB 767/02
10,0 cm/4"



ARRUGA
AB 768/01
10,0 cm/4"

ungeeicht
not calibrated
non calibrada
non calibrée
non calibrata



ELSCHNIG 1:2
AB 792/11
11,0 cm/4¹/₃"



McPHERSON
AB 819/02
10,0 cm/4"



MOD. BONN
AB 825/02
10,0 cm/4"



10 x
0,12 mm



FAULKNER
AB 848/11
11,0 cm/4¹/₃"



McDONALD
AB 852/02
10,0 cm/4"

ZS 160/45 CATARACT PHACOEMULSIFICATION SET

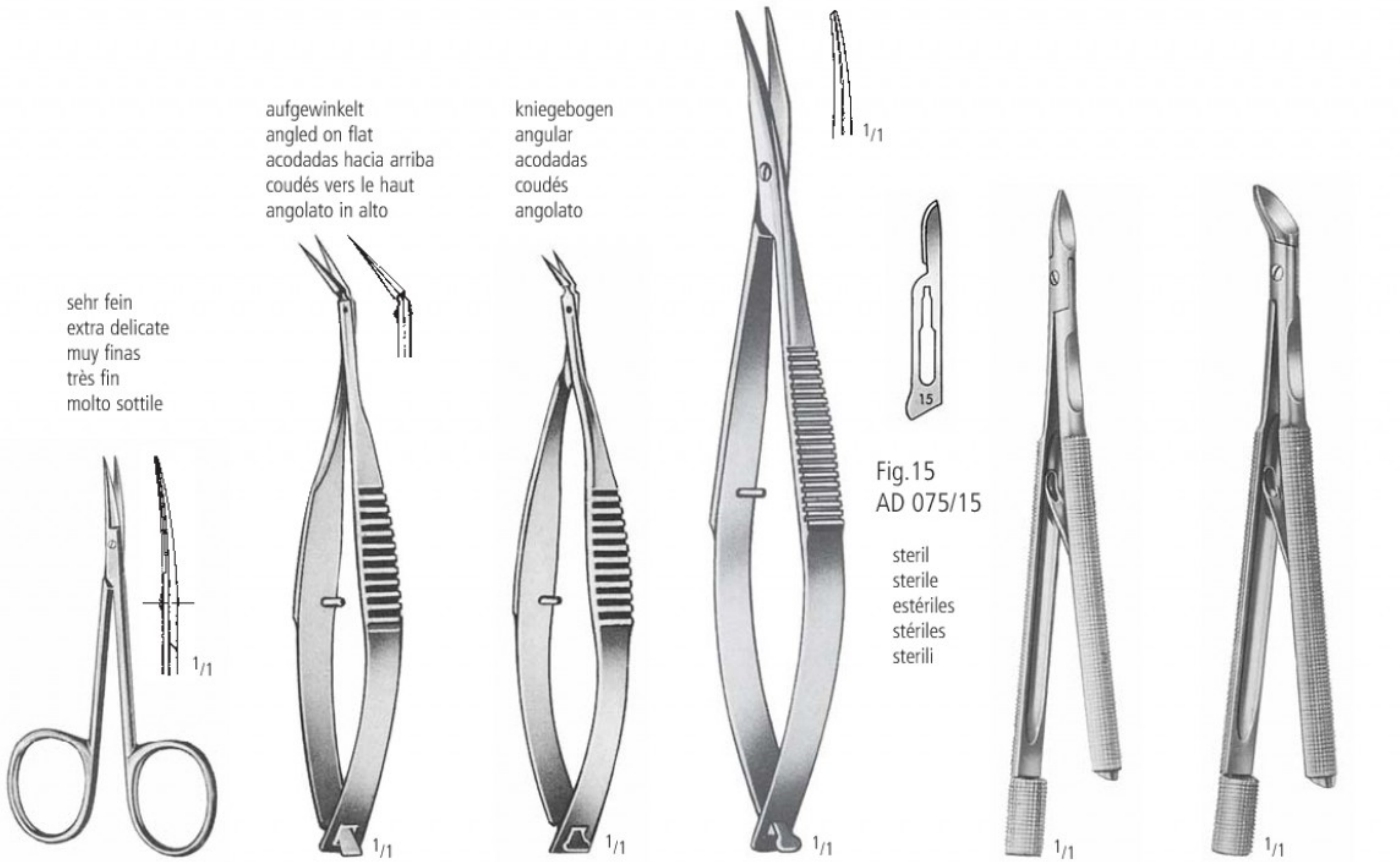

MOD. BONN
AC 431/08
8,0 cm/3"

VANNAS MOD. TÜBINGEN
AC 776/04
8,5 cm/3¹/₃"

VANNAS
AC 778/03
8,0 cm/3"

WESTCOTT
AC 782/11
11,0 cm/4¹/₃"

TROUTMAN-CHRIS
AD 550/09
Ø 5,5 mm
9,0 cm/3¹/₂"

TROUTMAN-CHRIS
AD 551/09
Ø 5,5 mm
9,0 cm/3¹/₂"

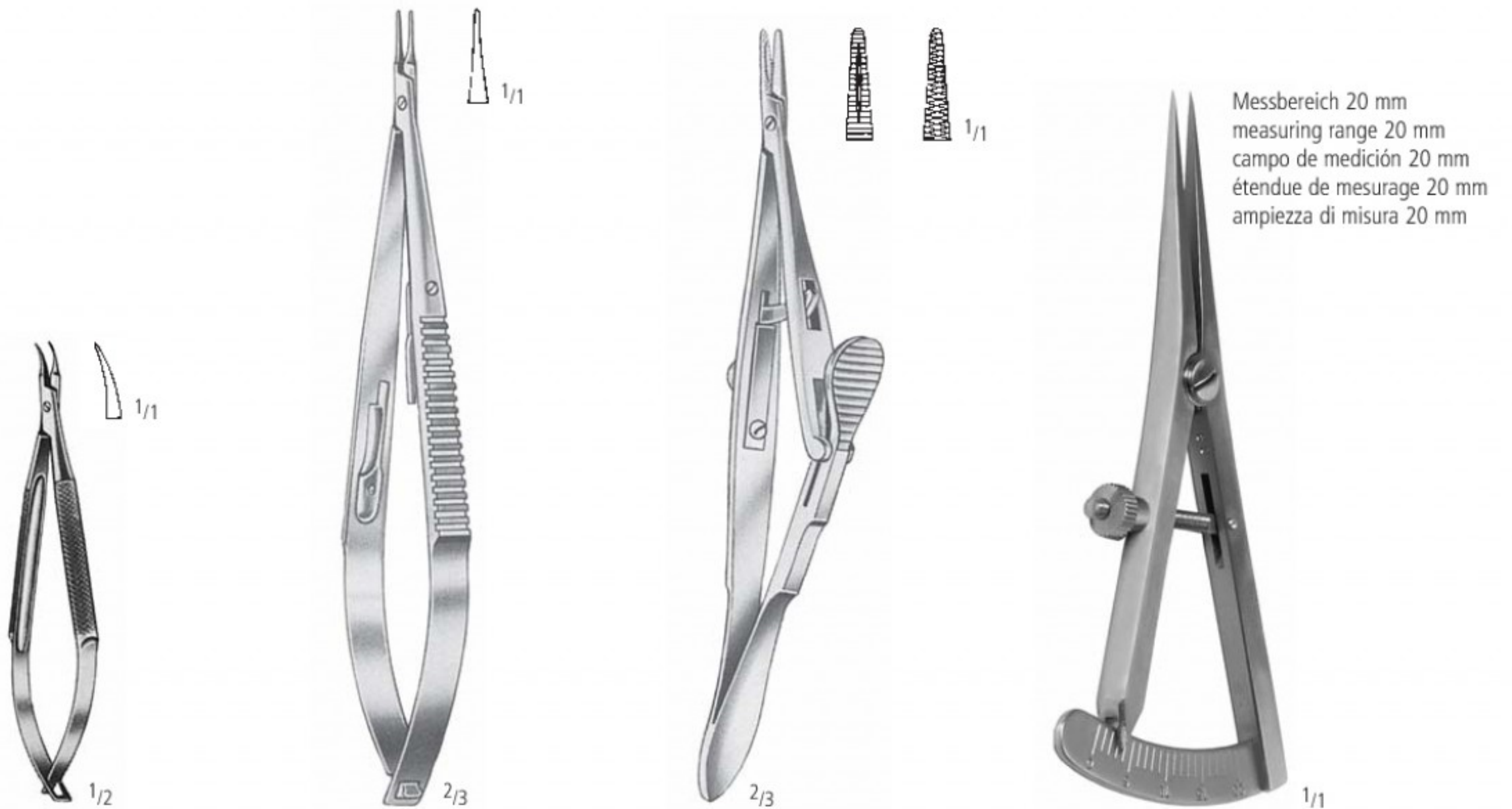

BARRAQUER
AE 605/11
11,0 cm/4¹/₃"

CASTROVIEJO
AE 660/14
14,0 cm/5¹/₂"

KALT
AE 688/14
14,0 cm/5¹/₂"

CASTROVIEJO
AR 282/20
8,0 cm/ 3"

ZS 160/45 CATARACT PHACOEMULSIFICATION SET

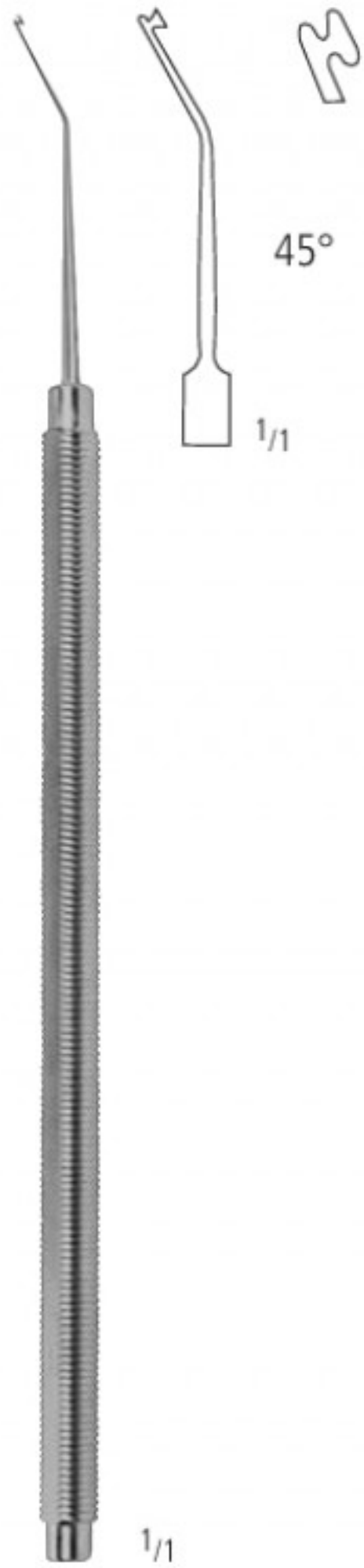

HIRSCHMANN
KP 030/13
12,5 cm/5"

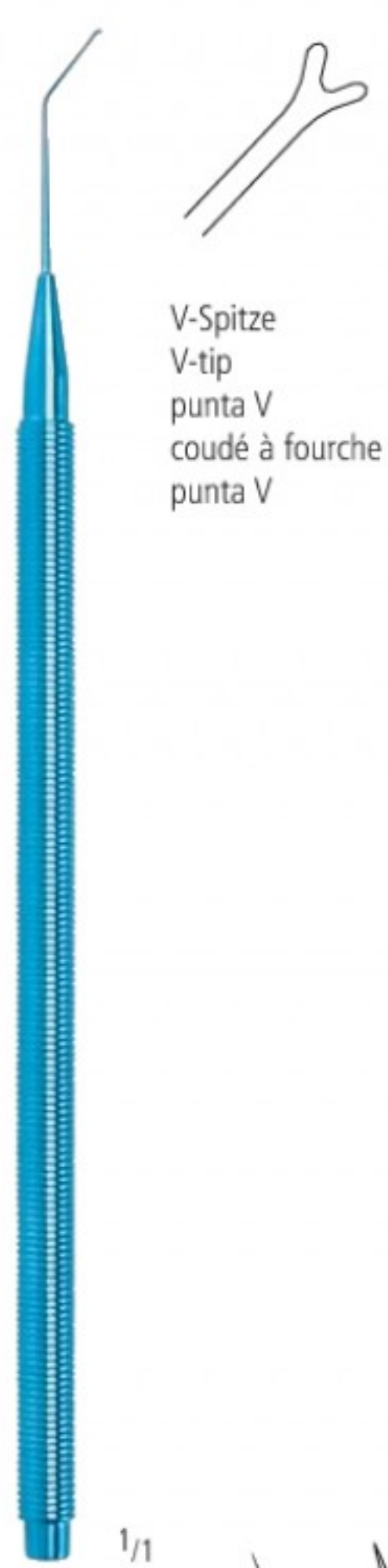

V-Spitze
V-tip
punta V
coudé à fourche
punta V

JAFFE-BECHERT
KP 040/02
12,0 cm/4³/₄"
L = 9 mm

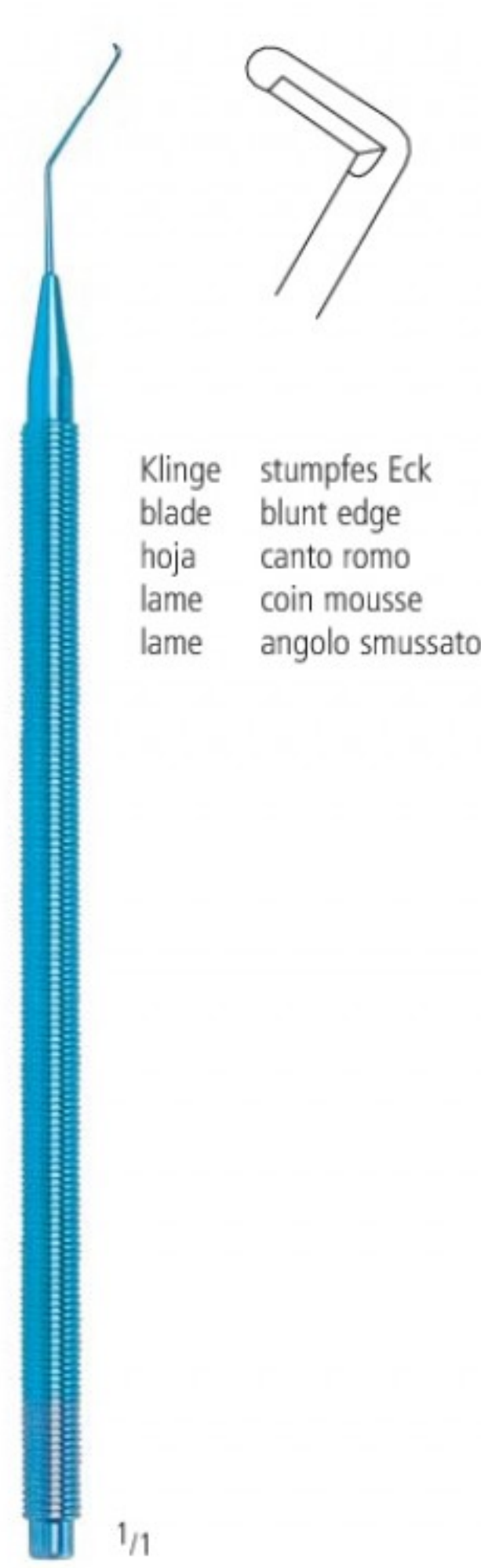

Klinge
blade
hoja
lame
lame

stumpfes Eck
blunt edge
canto romo
coin mousse
angolo smussato

NAGAHARA
KP 067/60
12,0 cm/4³/₄"
60°

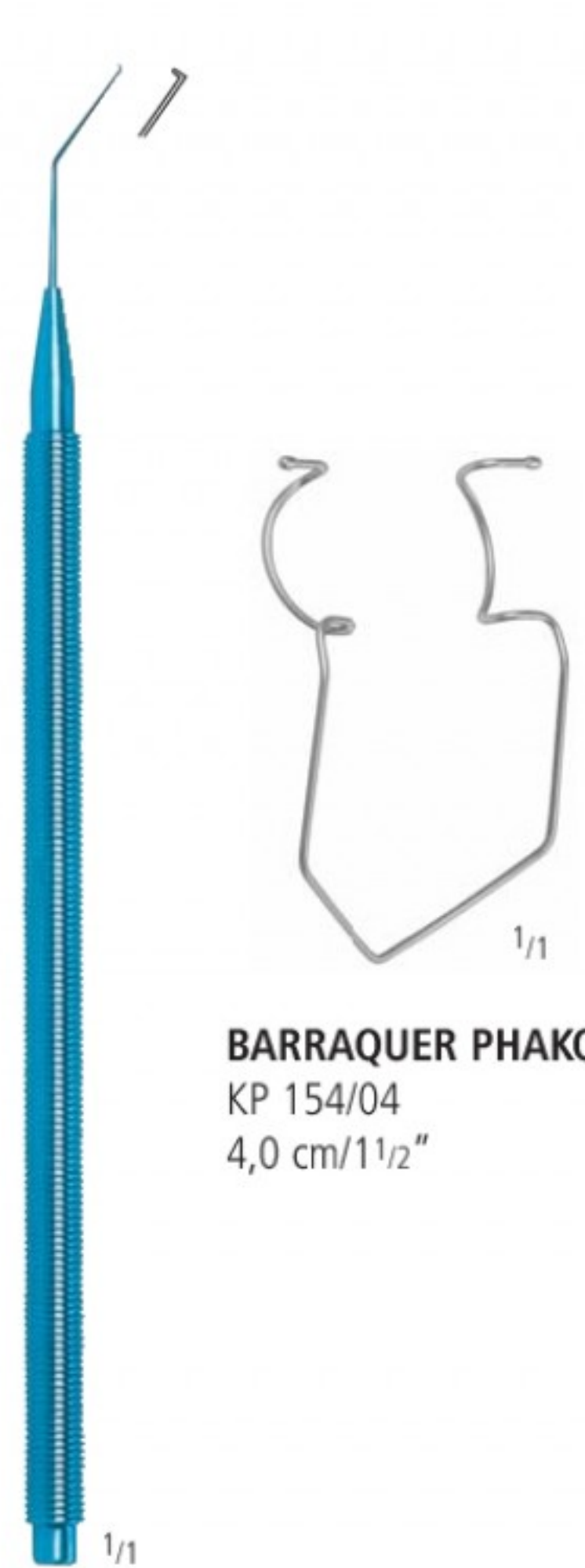

BARRAQUER PHAKO
KP 154/04
4,0 cm/1¹/₂"

SINSKEY
KP 071/25
12,0 cm/4³/₄"
Ø 0,25 mm



K-förmig
K-shaped
forma K
forme K
forme K

LIEBERMAN
KP 210/02
8,0 cm/3¹/₄"
B = 15 mm

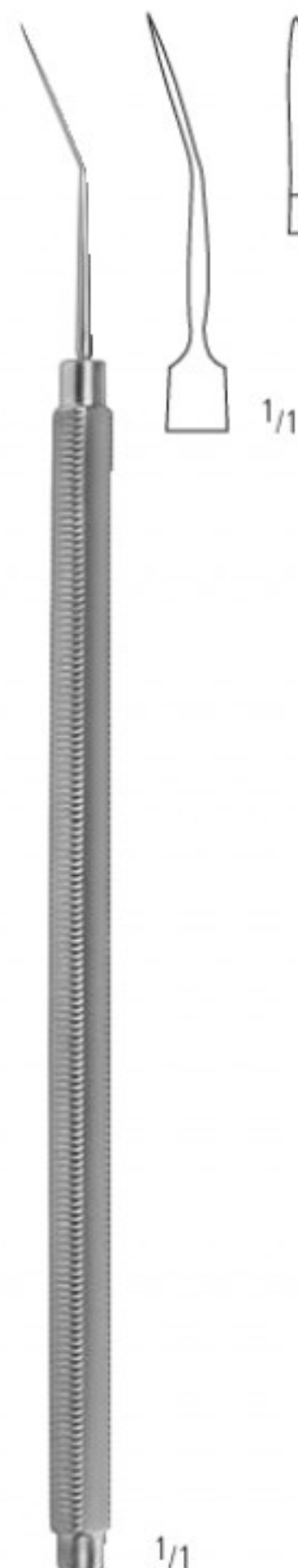

60°
1,4
KP 370/04

MOD. HAMBURG
KP 335/12
12,0 cm/ 4³/₄"



3F
1,0
KP 371/01

2,0
KP 371/02

ZS 160/45 CATARACT PHACOEMULSIFICATION SET



MALONEY
KP 545/02
2,0 cm/3/4"

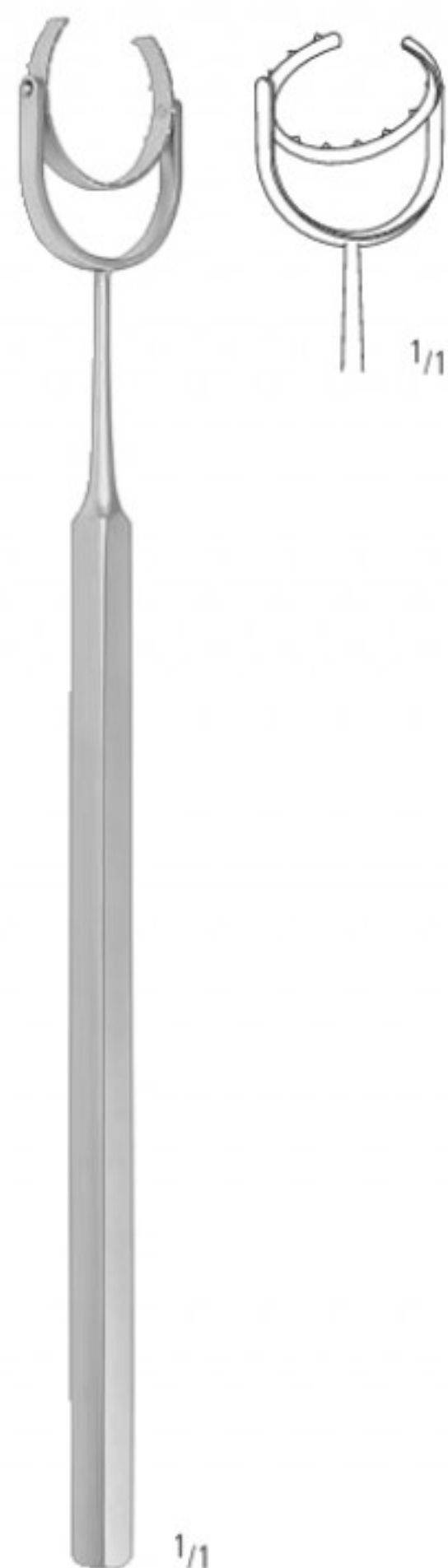

THORNTON
KP 550/12
12,0 cm/4 3/4"
Ø 13 mm

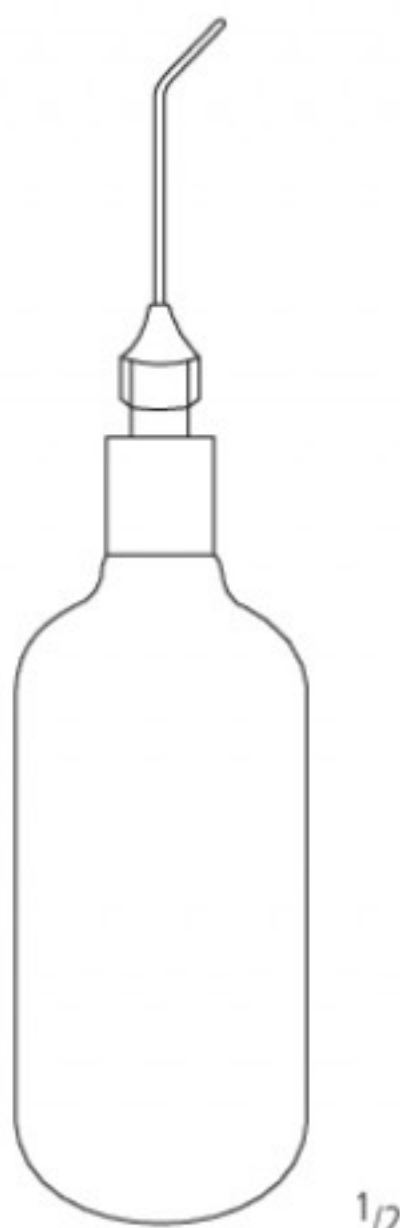

BISHOP-HARMON
KP 700/00

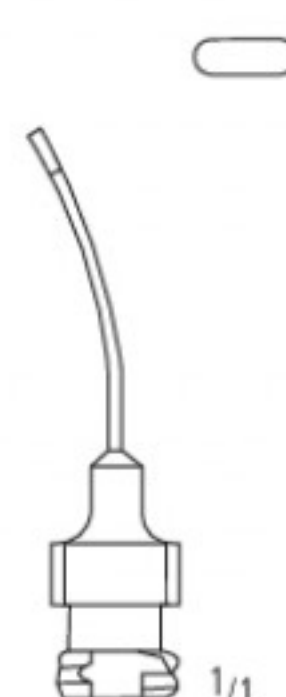

SAUTTER
KP 731/27
3,5 cm/1 1/2"
27G

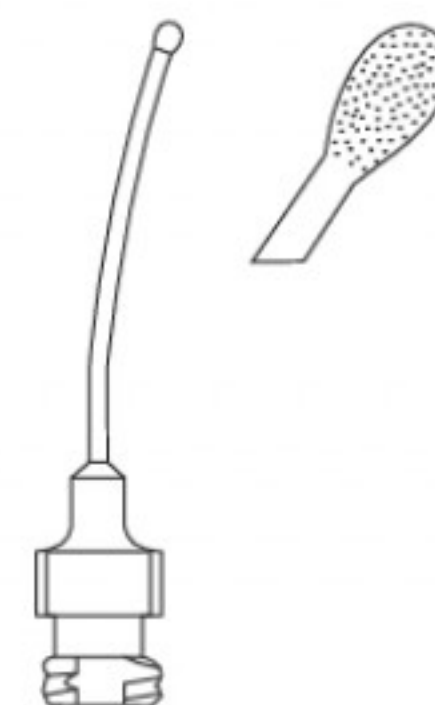

JENSEN
KP 767/27
4,5 cm/2"
27G

Set komplett
Set complete
Juego completo
Jeu complet
Set completo

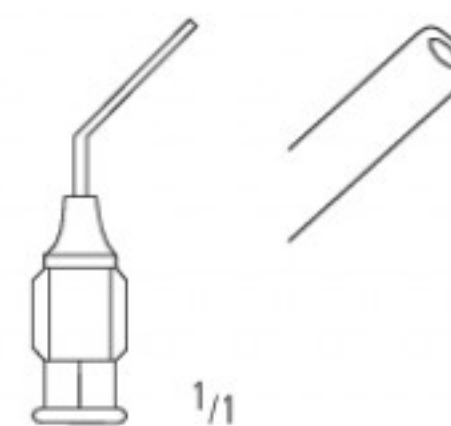

McINTYRE
2,5 cm/1"
KP 712/27
27G

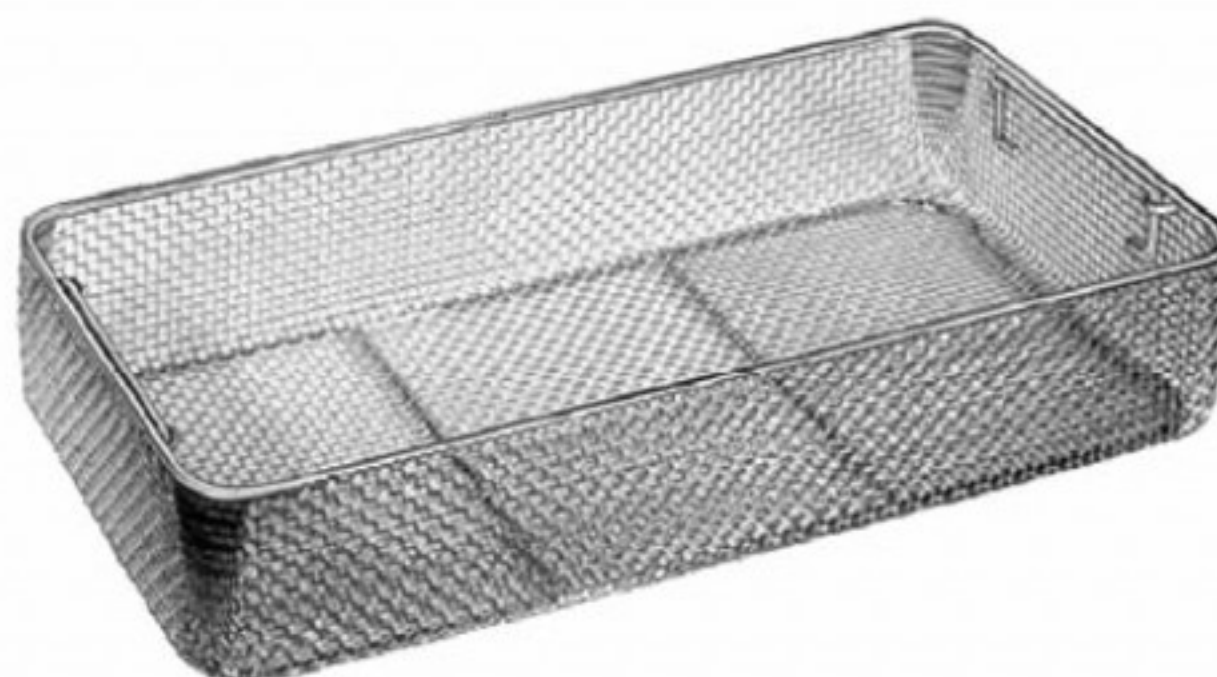

L(mm)	B(mm)	H(mm)	
485	255	50	SK 305/05

ZS 160/50 KERATOPLASTY

Contents:		Qty
AA 150/14	HALSTED-MOSQUITO ART.FCPS STR 14,0 CM	1
AA 751/15	BACKHAUS TOWEL FORCEPS 15,0 CM	2
AB 714/10	GRAEFE IRIS FORCEPS STR 1X2 TEETH 10,0 CM	1
AB 750/07	BARRAQUER-KATZIN FIX.FCPS 1X2 T. 7,0 CM	1
AB 792/11	ELSCHNIG FIXATION FORCPES 1X2 TEETH 11,0 CM	1
AB 816/10	CASTROVIEJO SUTURE FORCEPS 1.0MM 10,0 CM	1
AB 825/02	BONN SUTURE FORCEPS 10,0 CM ULRTA FINE	2
AC 431/08	MOD.BONN SCISSORS CVD 8,0 CM	1
AC 778/01	VANNAS SEC.CATARACT SCISSORS,STR. 8,0 CM	1
AC 782/11	WESTCOTT TENOTOMY SCISSORS BLUNT 11,0 CM	1
AC 785/01	CASTROVIEJO DELICATE EYE SCS.10,0 CM RIGHT	1
AC 791/01	KATZIN MICRO SCISSORS LEFT 11,0 CM	1
AC 791/02	KATZIN MICRO SCISSORS RIGHT 11,0 CM	1
AE 605/14	BARRAQUER MICRO-NEEDLE HOLDER CVD 14,0 CM	1
AE 660/14	CASTROVIEJO NH STR RA SMOOTH 14,0 CM	1
AE 688/14	KALT MICRO-NEEDLE HOLDER STR 14,0 CM	1
KP 150/15	BARRAQUER-COLIBRI EYE SPECULA 15 MM 4,0 CM	1
KP 325/05	BONN SCLERA KNIFE 5MM 12,5 CM	1
KP 370/02	PREMIUM DIAMOND KNIFE STR. 1,0 CM 45°	1
KP 508/10	BORES AXIS MARKER 10,0 CM	1
KP 535/12	ANIS SUTURE PLACEMENT MARKER 8 BLADES	1
KP 545/02	MALONEY KERATOMETER INTRAOPERATIVE 2,0 CM	1
KP 603/70	FRANCESCHETTI CERATOPLASTY TREPHINE	1
KP 603/80	FRANCESCHETTI CERATOPLASTY TREPHINE	1
KP 640/14	FLIERINGA SCLERAL FIXATION RING Ø 14,0 MM	1
KP 640/16	FLIERINGA SCLERAL FIXATION RING Ø 16,0 MM	1
KP 640/18	FLIERINGA SCLERAL FIXATION RING Ø 18,0 MM	1
KP 640/20	FLIERINGA SCLERAL FIXATION RING Ø 20,0 MM	1
KP 700/00	BISHOP-HARMON ANTERIOR CHAMBER	1
KP 731/27	SAUTTER AIR INJECTION CANNULA 27G 3,5 CM	2
SK 305/05	WIRE BASKET, 485 X 255 X 50 MM	1

Sterilization Container KYE 200/61, if required



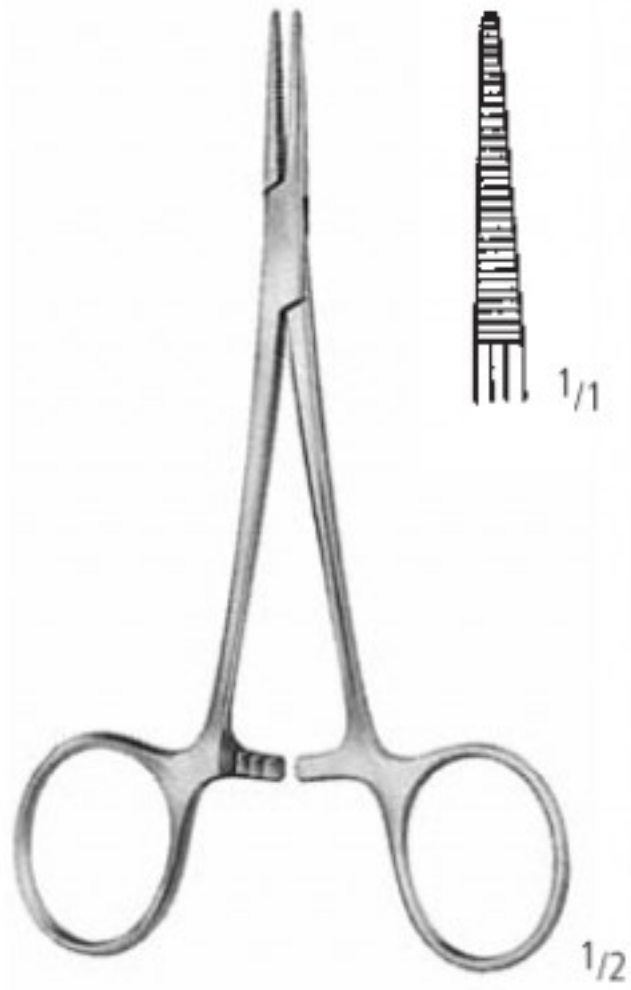

HALSTED-MOSQUITO
AA 150/14
14,0 cm/5¹/₂"

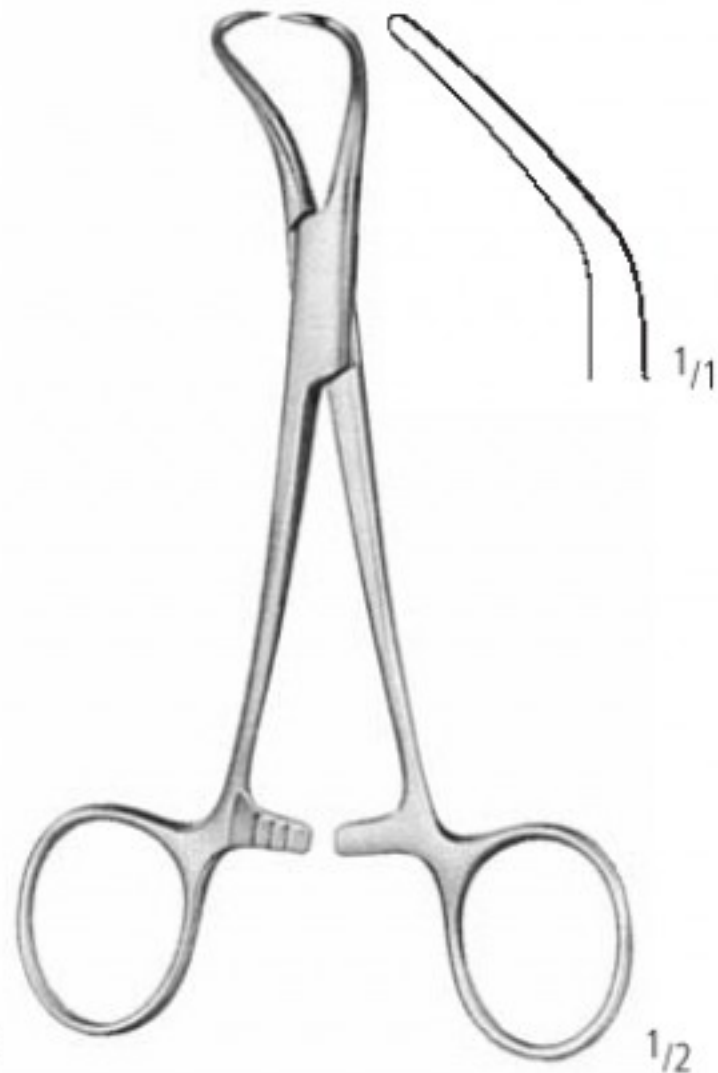

BACKHAUS
AA 751/15
15,0 cm/6"

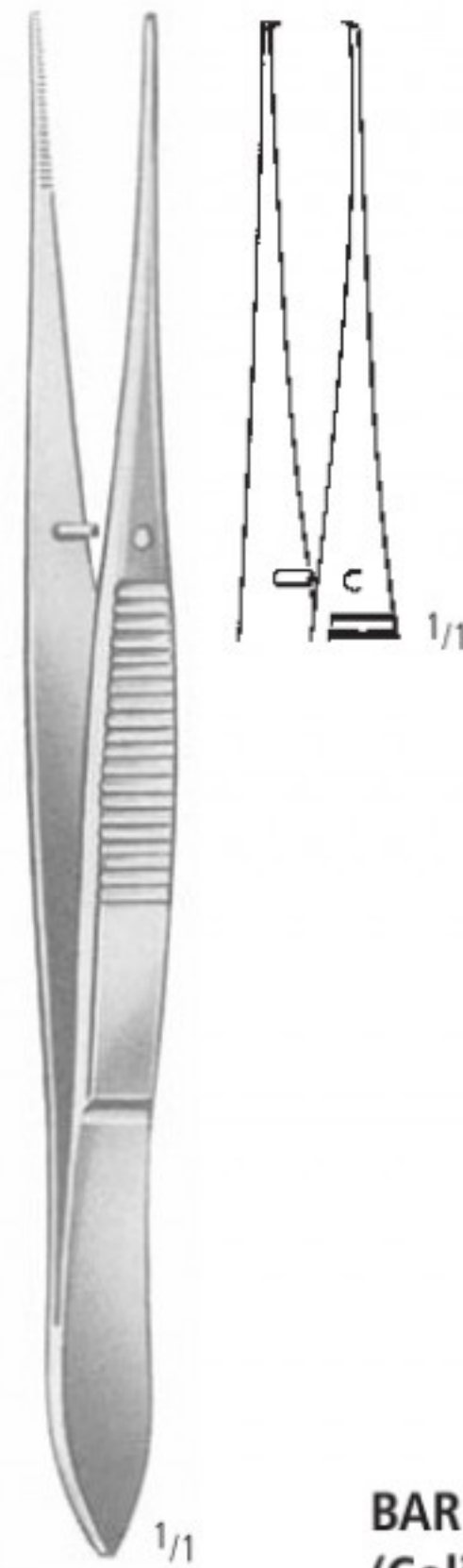

GRAEFE
AB 714/10
10,0 cm/4"



BARRAQUER-KATZIN 1:2 (Colibri)
AB 750/07
7,0 cm/2³/₄"



ELSCHMIG 1:2
AB 792/11
11,0 cm/4¹/₃"



CASTROVIEJO 1:2
AB 816/10
1,00 mm
10,0 cm/4"



MOD. BONN
AB 825/02
10,0 cm/4"

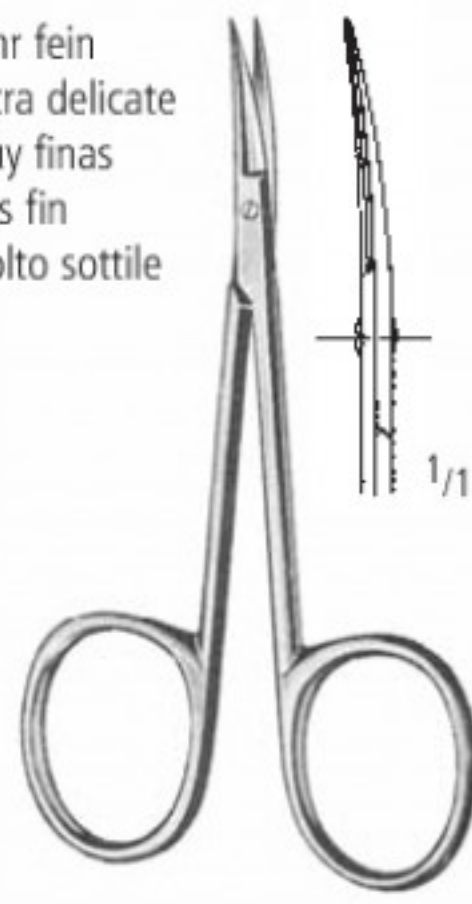

MOD. BONN
AC 431/08
8,0 cm/3"

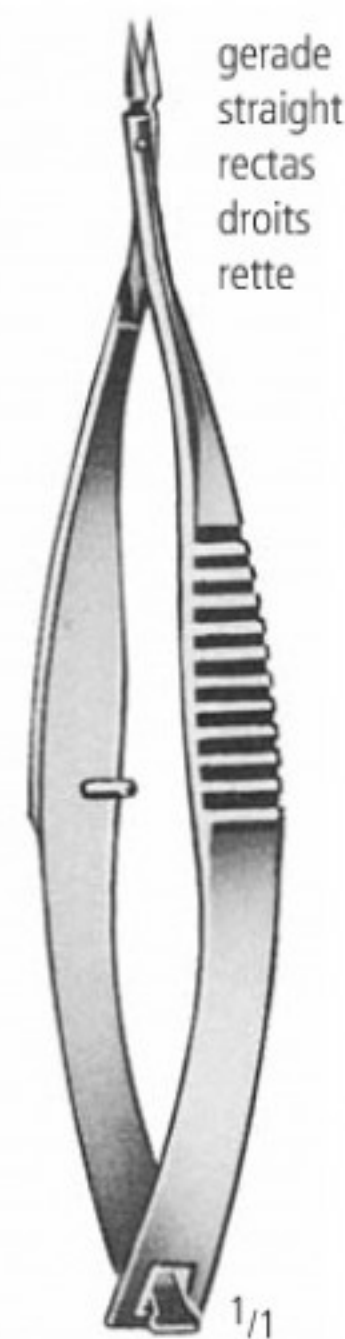

VANNAS
AC 778/01
8,0 cm/3"



WESTCOTT
AC 782/11
11,0 cm/4¹/₃"

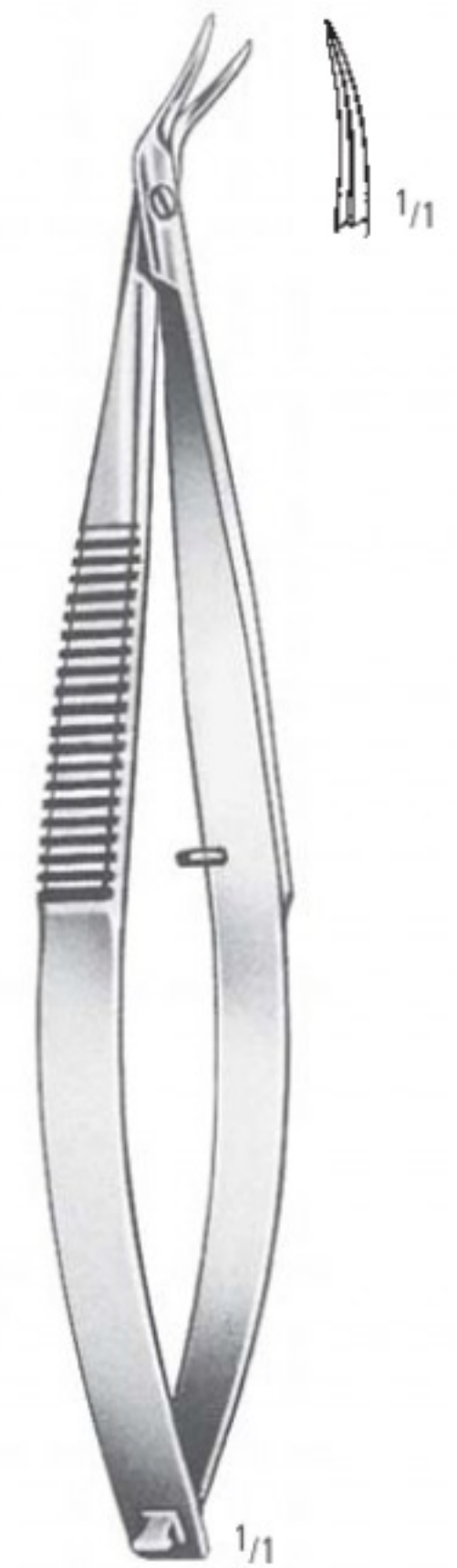

CASTROVIEJO
AC 785/01
10,0 cm/4"

sehr fein
extra delicate
muy finas
très fin
molto sottile

gerade
straight
rectas
droits
rette

ZS 160/50 KERATOPLASTY

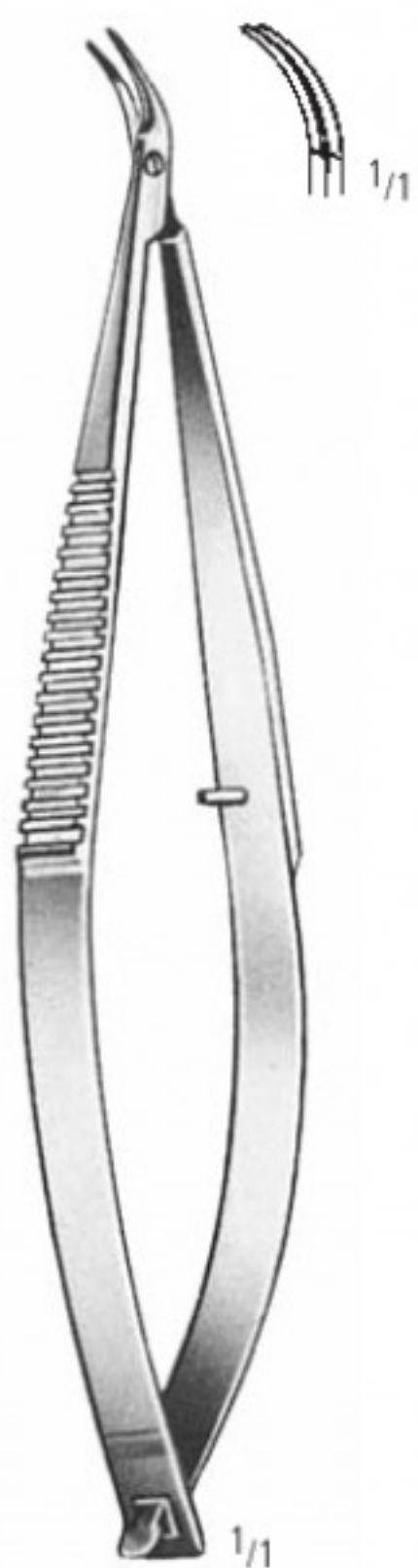

KATZIN
AC 791/01
11,0 cm/4¹/₃"

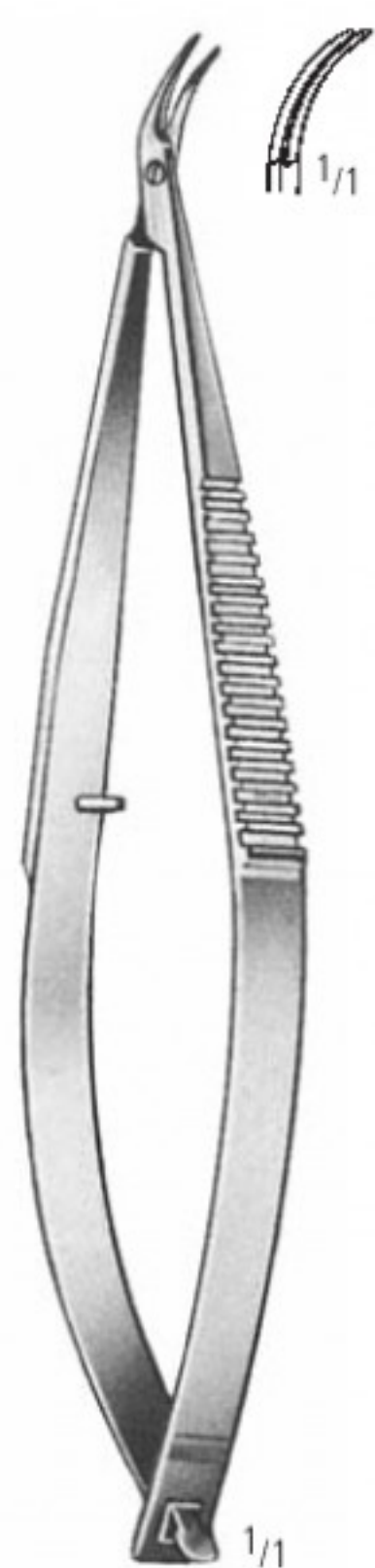

KATZIN
AC 791/02
11,0 cm/4¹/₃"



BARRAQUER
AE 605/11
11,0 cm/4¹/₃"



CASTROVIEJO
AE 660/14
14,0 cm/5¹/₂"



KALT
AE 688/14
14,0 cm/5¹/₂"



BARRAQUER-COLIBRI
B
15 mm KP 150/15
4,0 cm/1¹/₂"

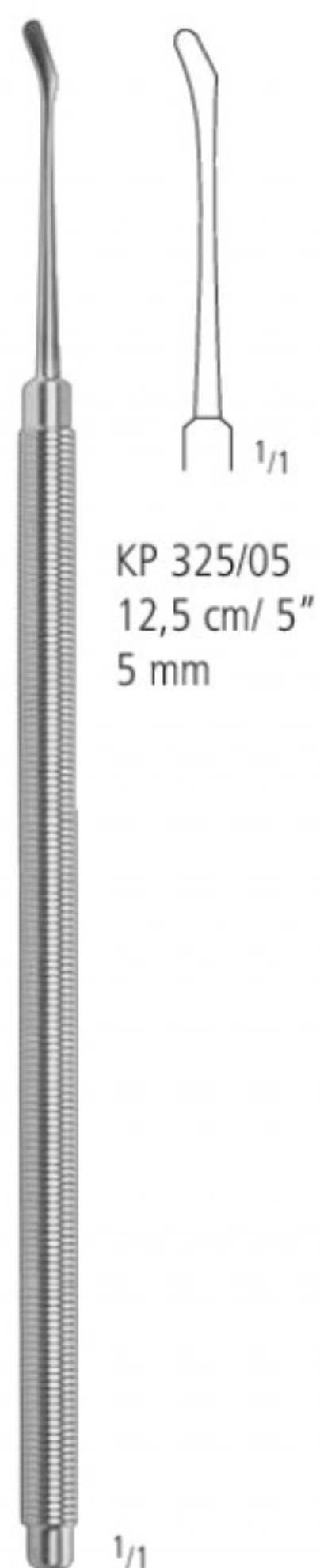

BONN

KP 325/05
12,5 cm/ 5"
5 mm



KP 370/02

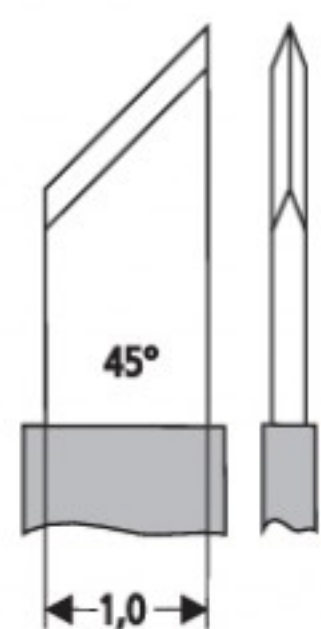

BORES
KP 508/10
10,0 cm/4"



ANIS
KP 535/12
12,0 cm/4³/₄"



MALONEY
KP 545/02
2,0 cm/3¹/₄"



mm Ø
7,0 KP 603/70
8,0 KP 603/80
FRANCESCETTI
7,5 cm/3"

Set komplett
Set complete
Juego completo
Jeu complet
Set completo



FLIERINGA

mm Ø

- 14 KP 640/14
- 16 KP 640/16
- 18 KP 640/18
- 20 KP 640/20



BISHOP-HARMON
KP 700/00

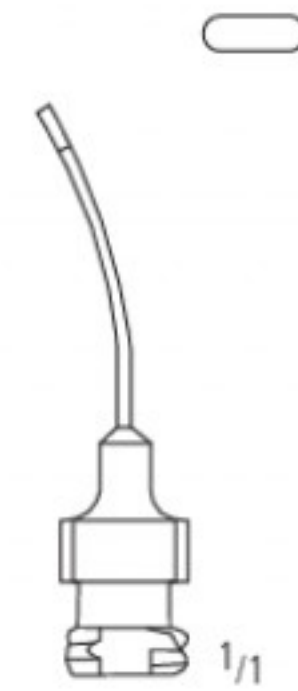

SAUTER
KP 731/27
3,5 cm/1 1/2"
27G

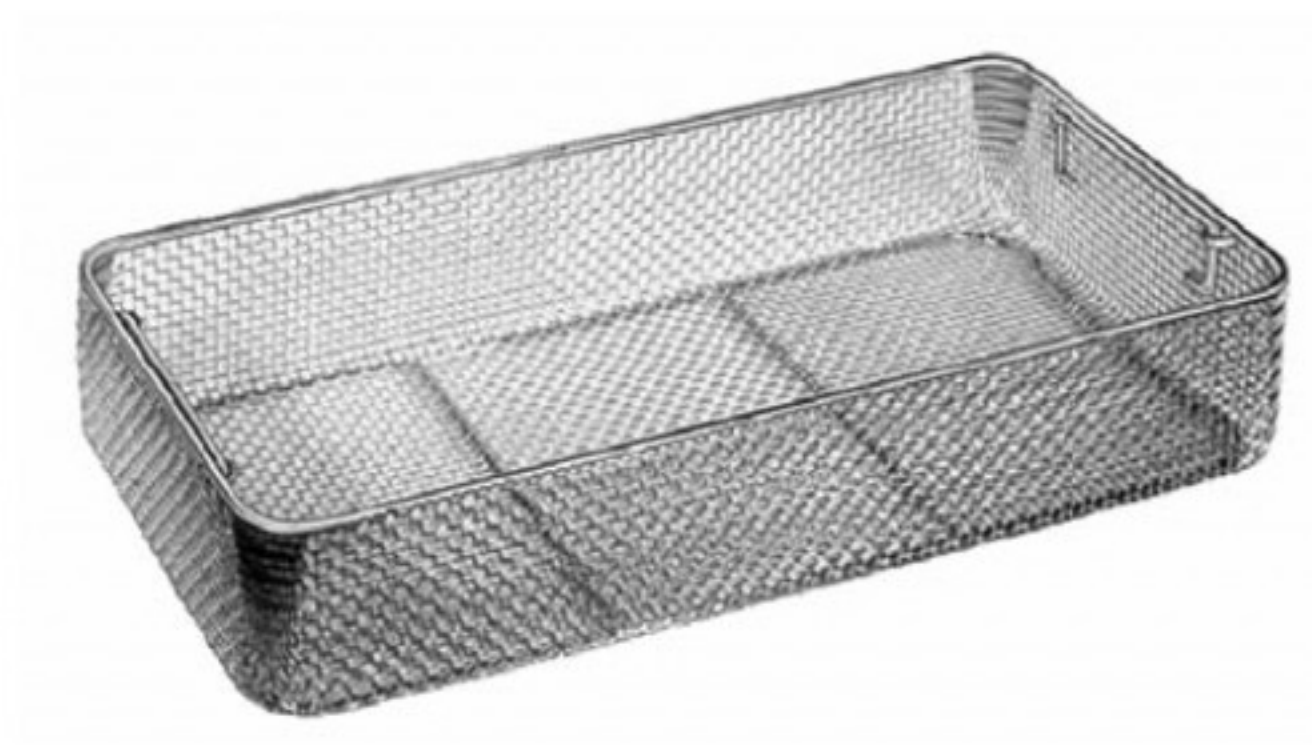

L(mm)	B(mm)	H(mm)	
485	255	50	SK 305/05

ZS 160/55 LASIK SET

Contents:		Qty
AB 819/02	MCPHERSON TYING FORCEPS ANGLED 10,5 CM	1
KP 210/02	LIEBERMAN EYE SPECULA 15 MM K-SHAPE 8,0 CM	1
KP 211/08	LIEBERMAN EYE SPECULA 15 MM 8,0 CM ASP.	1
KP 270/10	LASIK FLAP SMOOTHER 10,0 CM	1
KP 487/14	CASTROVIEJO CYCLODIALYSIS SPATULA 13,5 CM	1
KP 489/12	BARRAQUER-FINO CYCLODIALYSIS SPATULA 11,5 CM	1
KP 516/11	LU CORNEAL MARKER LASIK Ø 8,5MM 10,5 CM	1
KP 550/12	THORNTON FIXATION RING FG-HINGE Ø 13,0 MM	1
KP 701/19	BISHOP-HARMON IRRIGATION CANNULA 19G 4,0 CM	1
KP 731/27	SAUTTER AIR INJECTION CANNULA 27G 3,5 CM	1
SK 105/05	WIRE BASKET, 255 X 245 X 50 MM	1

Sterilization Container KYE 200/11, if required



ZS 160/55 LASIK SET



McPHERSON
AB 819/02
10,0 cm/4"



LIEBERMAN
KP 210/02
8,0 cm/3¹/₄"
B = 15 mm



LIEBERMAN
KP 211/08
8,0 cm/3¹/₄"
B = 15 mm



LASIK
KP 270/10
10,0 cm/4"



CASTROVIEJO
KP 487/14
13,5 cm/5¹/₄"
0,5 x 10/16 mm



BARRAQUER-FINO
KP 489/12
11,5 cm/4¹/₂"
0,25 x 12 mm

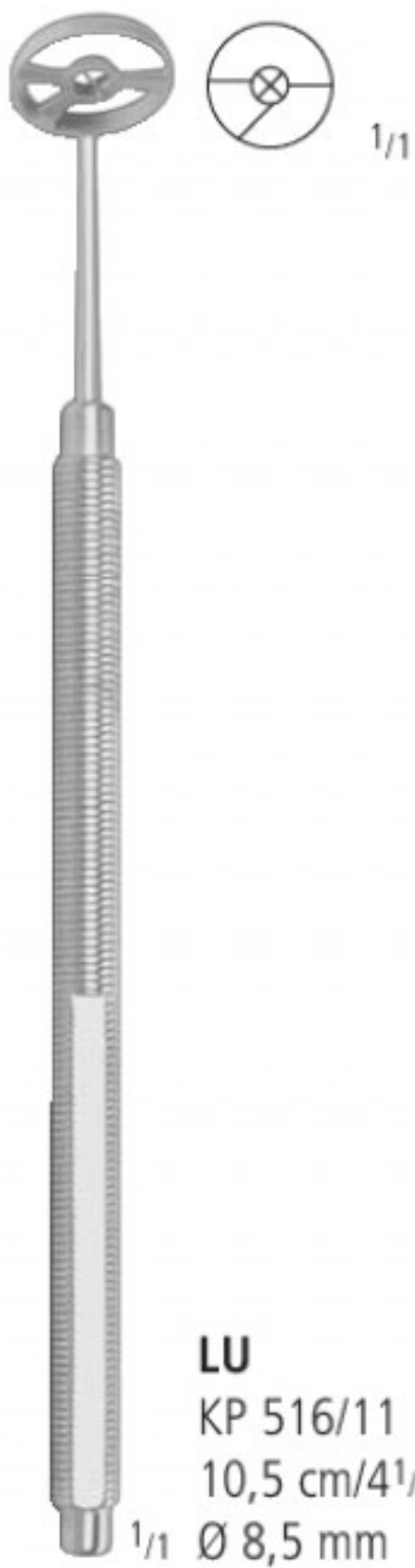

LU
KP 516/11
10,5 cm/4¹/₄"
Ø 8,5 mm

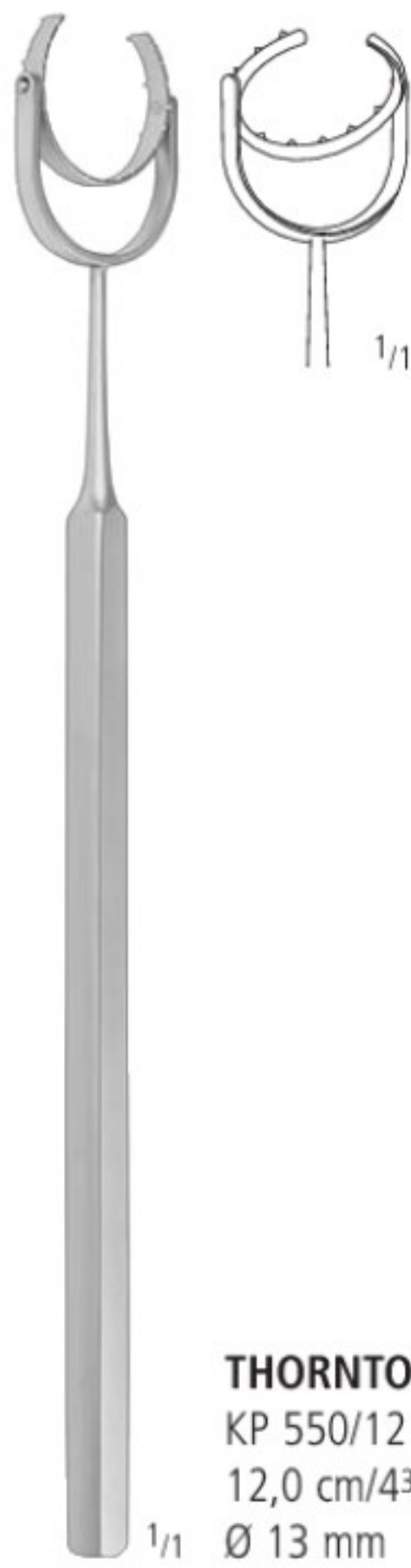

THORNTON
KP 550/12
12,0 cm/4³/₄"
Ø 13 mm

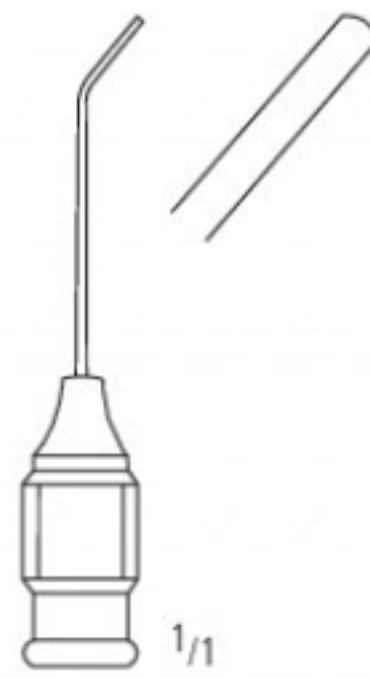

BISHOP-HARMON
KP 701/19
4,0 cm/1¹/₂"
19G

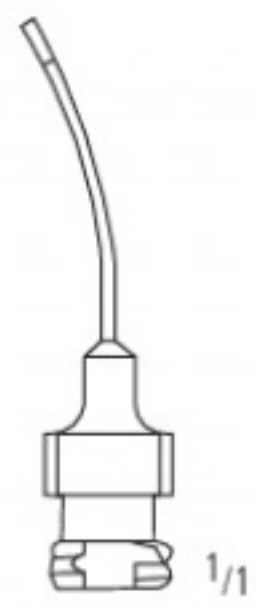

SAUTTER
KP 731/27
3,5 cm/1¹/₂"
27G



L(mm)	B(mm)	H(mm)	
255	245	50	SK 105/05

ZS 160/60 LID-CONJUNCTIVA / TRICHIASIS-PTOSIS SET

Contents:		Qty
AA 150/14	HALSTED-MOSQUITO ART.FCPS STR 14,0 CM	2
AA 151/14	HALSTED-MOSQUITO ART.FCPS CVD 14,0 CM	2
AA 711/09	JONES TOWEL FORCEPS 9,0 CM	2
AB 628/09	ZIEGLER CILIA FORCEPS 9,0 CM	1
AB 785/01	GRAEFE FIX.FCPS W/O SPRING CATCH 11,0 CM	1
AB 816/01	CASTROVIEJO SUTURE FORCEPS 10,0 CM	2
AB 824/02	BONACCOLTO SUTURE FORCEPS 10,0 CM FINE	1
AB 829/01	HARMS TYING FORCEPS STRAIGHT 10,0 CM	1
AB 840/01	DESMARRES CHALAZION FORCEPS FIG.1 9,0 CM	1
AB 841/01	LAMBERT CHALAZION FORCEPS 9,0 CM ROUND	1
AB 844/20	BERKE PTOSIS FORCEPS 11,0 CM, 20 MM	1
AC 450/10	IRIS SCISSORS STR SH/SH 10,5 CM	1
AC 475/10	STEVENS TENOTOM.SCS POINTED CVD 10,5 CM	1
AC 782/11	WESTCOTT TENOTOMY SCISSORS BLUNT 11,0 CM	1
AC 797/01	WESTCOTT STRABISMUS SCS STR SHARP 11,5 CM	1
AE 663/14	CASTROVIEJO NH CVD RA SERRATED 14,0 CM	1
AE 688/14	KALT MICRO-NEEDLE HOLDER STR 14,0 CM	1
AK 074/01	GUTHRIE DELICATE HOOK FIG.1 16,0 CM	1
AK 078/13	KNAPP DELICATE HOOK BLUNT 13,0 CM	1
AK 090/12	DESMARRES RETRACTOR 12 MM 13,0 CM	1
AK 090/14	DESMARRES RETRACTOR 14 MM 13,0 CM	1
AK 090/16	DESMARRES RETRACTOR 16 MM 13,0 CM	1
AR 282/20	CASTROVIEJO CIRCLE 8,0 CM STRAIGHT	1
KP 015/01	GRAEFE STRABISMUS HOOK #1 13,0 CM	1
KP 015/02	GRAEFE STRABISMUS HOOK #2 14,0 CM	1
KP 248/11	JAEGER LID PLATE 11,0 CM	1
KP 325/05	BONN SCLERA KNIFE 5MM 12,5 CM	1
KP 415/10	MEYHOEFER CHALAZION CURETTE 13,0 CM	1
KP 415/20	MEYHOEFER CHALAZIONCURETTE 13,0 CM 2,0 MM	1
KP 415/25	MEYHOEFER CHALAZIONCURETTE 13,0 CM 2,5 MM	1
KP 415/35	MEYHOEFER CHALAZIONCURETTE 13,0 CM 3,5 MM	1
KP 700/00	BISHOP-HARMON ANTERIOR CHAMBER	1
SK 305/05	WIRE BASKET, 485 X 255 X 50 MM	1

Sterilization Container KYE 200/61, if required



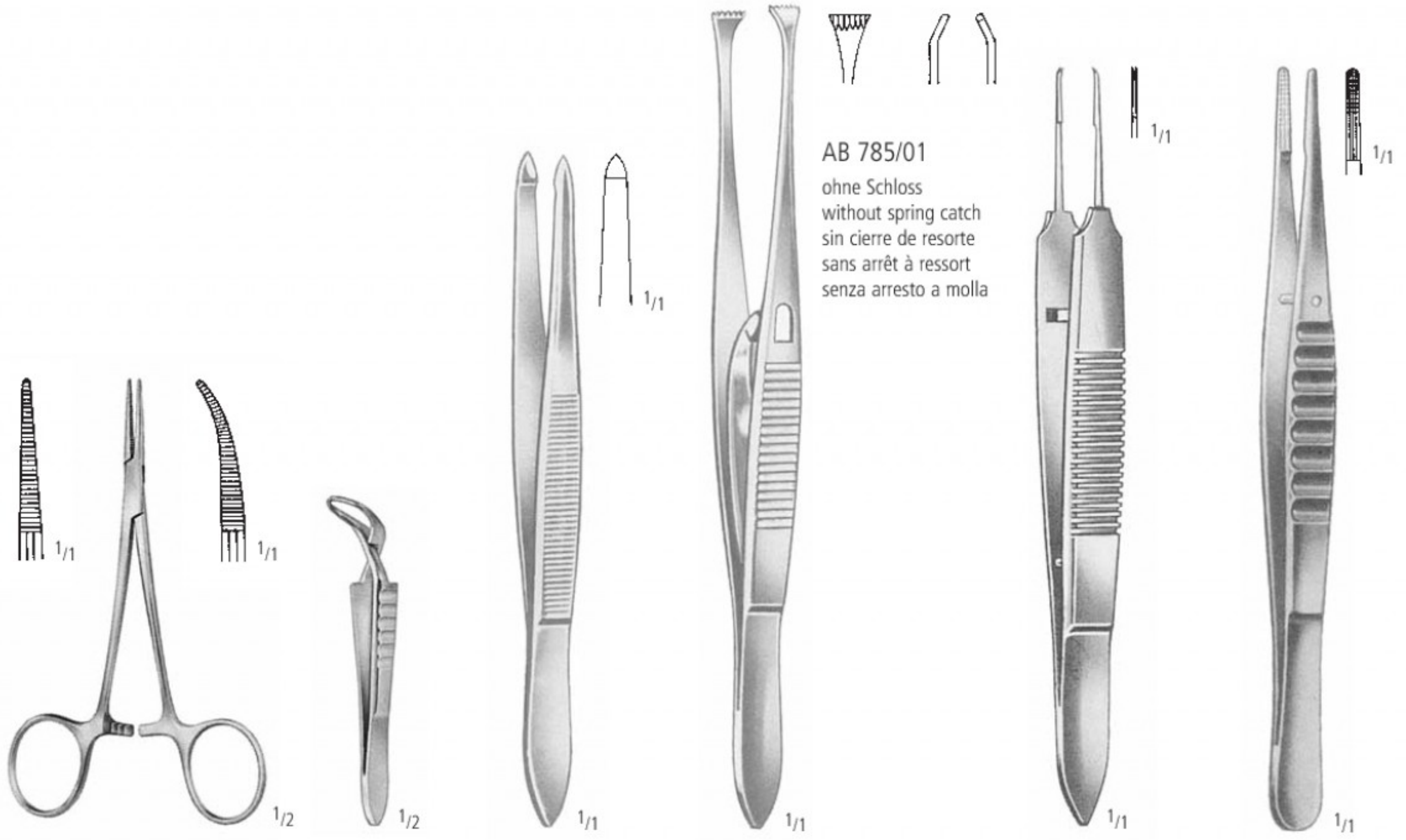

AB 785/01
ohne Schloss
without spring catch
sin cierre de resorte
sans arrêt à ressort
senza arresto a molla

HALSTED-MOSQUITO
AA 150/14 AA 151/14
14,0 cm/5¹/₂"

JONES
AA 711/09
9,0 cm/3¹/₂"

ZIEGLER
AB 628/09
9,0 cm/3¹/₂"

GRAEFE
11,0 cm/4¹/₃"

CASTROVIEJO 1:2
AB 816/01
0,12 mm
10,0 cm/4"

BONACCOLTO
AB 824/02
10,0 cm/4"

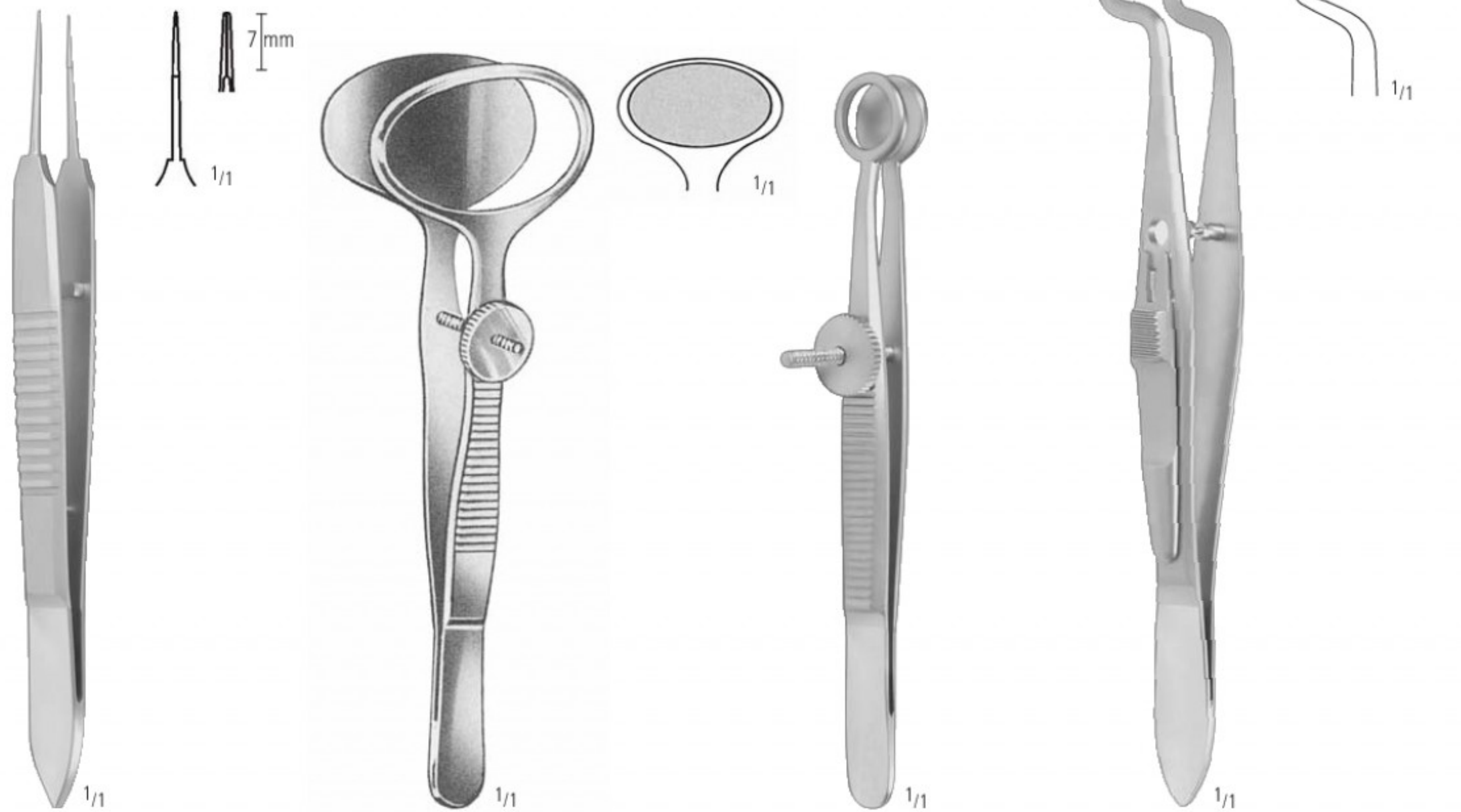

HARMS
AB 829/01
10,0 cm/4"

DESMARRES
AB 840/01
9,0 cm/3¹/₂"

LAMPERT
AB 841/01
9,0 cm/3¹/₂"

BERKE
AB 844/20
11,0 cm/4¹/₃"
20 mm

ZS 160/60 LID-CONJUNCTIVA / TRICHIASIS-PTOSIS SET

Irisscheren
Iris Scissors
Tijeras para iridectomía
Ciseaux à iridectomie
Forbici per iridectomia

Sehnenscheren
Tenotomy Scissors
Tijeras para tenotomía
Ciseaux à ténonomie
Forbici per tenotomia

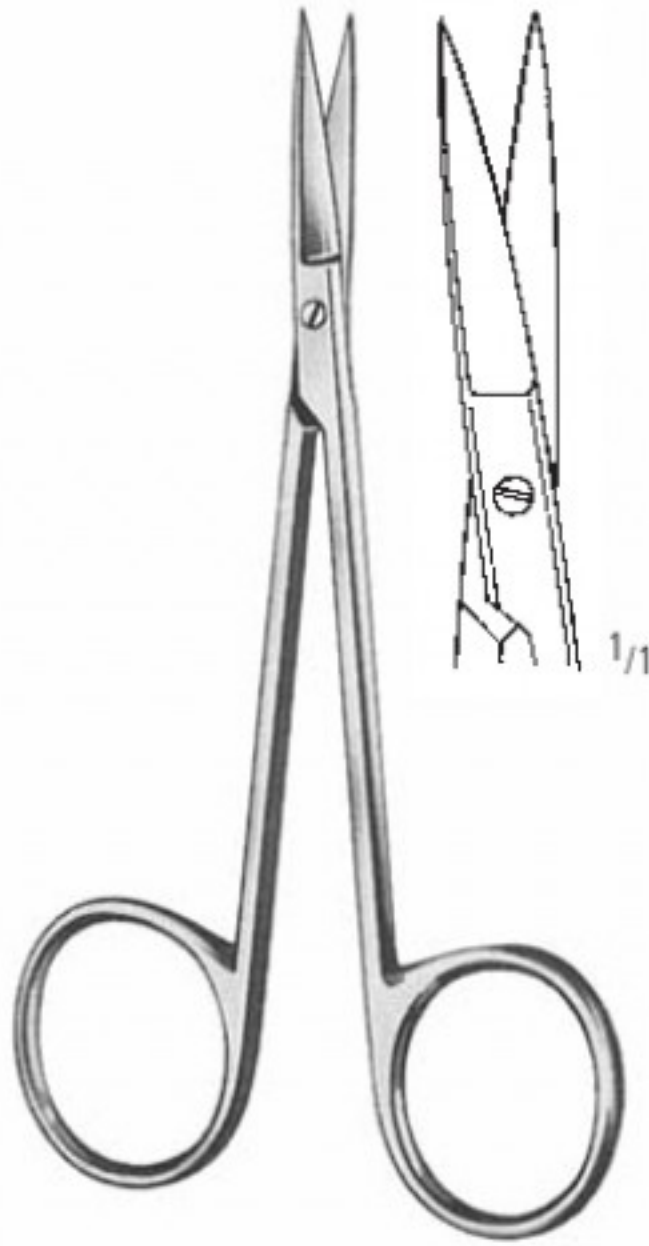

AC 450/10
10,5 cm/4 1/4"

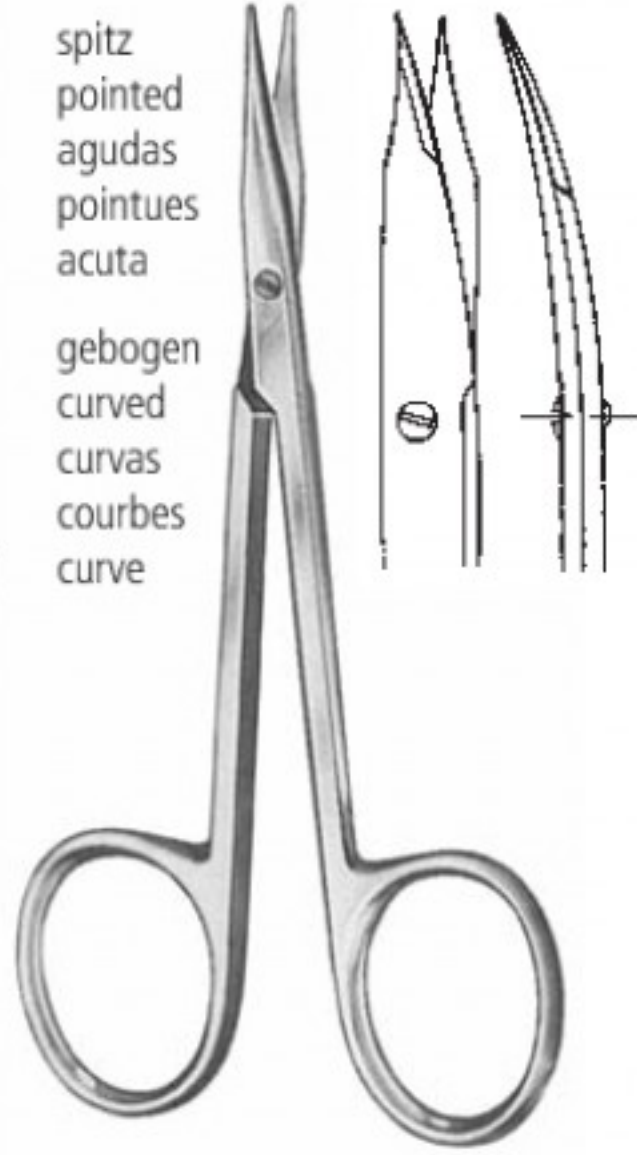

STEVENS
AC 475/10
10,5 cm/4 1/4"



WESTCOTT
AC 782/11
11,0 cm/4 1/3"



WESTCOTT
AC 797/01
11,5 cm/4 1/2"



CASTROVIEJO
AE 663/14
14,0 cm/5 1/2"



KALT
AE 688/14
14,0 cm/5 1/2"

spitz
pointed
agudas
pointues
acuta

gebogen
curved
curvas
courbes
curve

Messbereich 20 mm
measuring range 20 mm
campo de medición 20 mm
étendue de mesurage 20 mm
ampiezza di misura 20 mm



GUTHRIE
AK 074/01
16,0 cm/6 1/4"



KNAPP
AK 078/13
13,0 cm/5"



DESMARRES
13,0 cm/5"



CASTROVIEJO
AR 282/20
8,0 cm/ 3"



GRAEFE
KP 015/01
13,0 cm/5"
Fig. 1

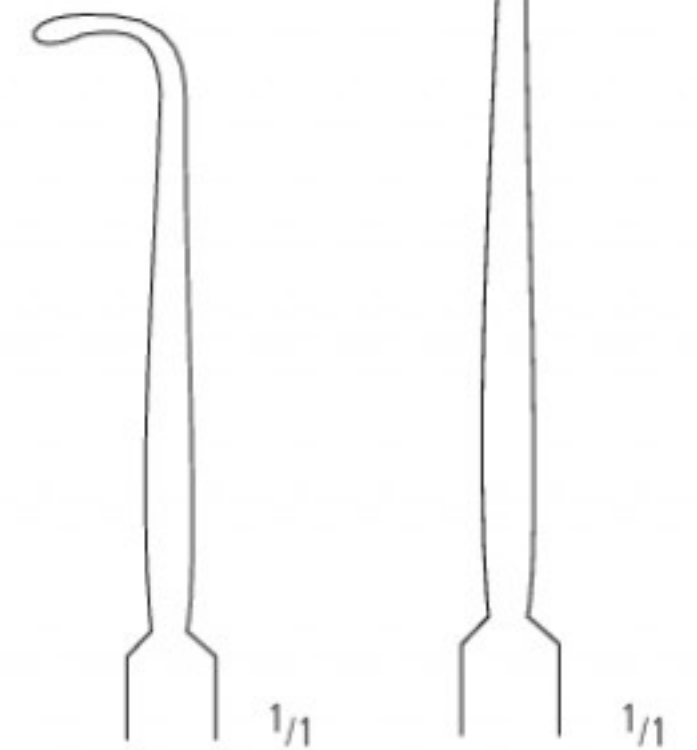

GRAEFE
KP 015/02
14,0 cm/5 1/2"
Fig. 2



JAEGER
KP 248/11
11,0 cm/4 1/2"

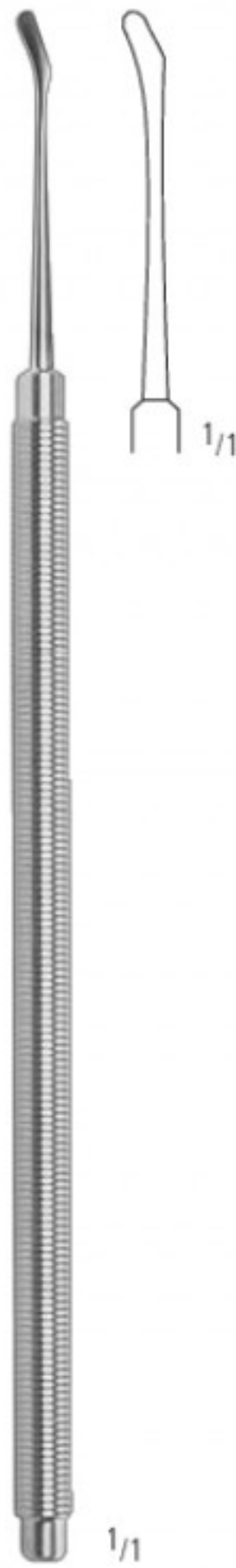

BONN
KP 325/05
12,5 cm/ 5"
5 mm



MEYHOEFER
13,0 cm/5"

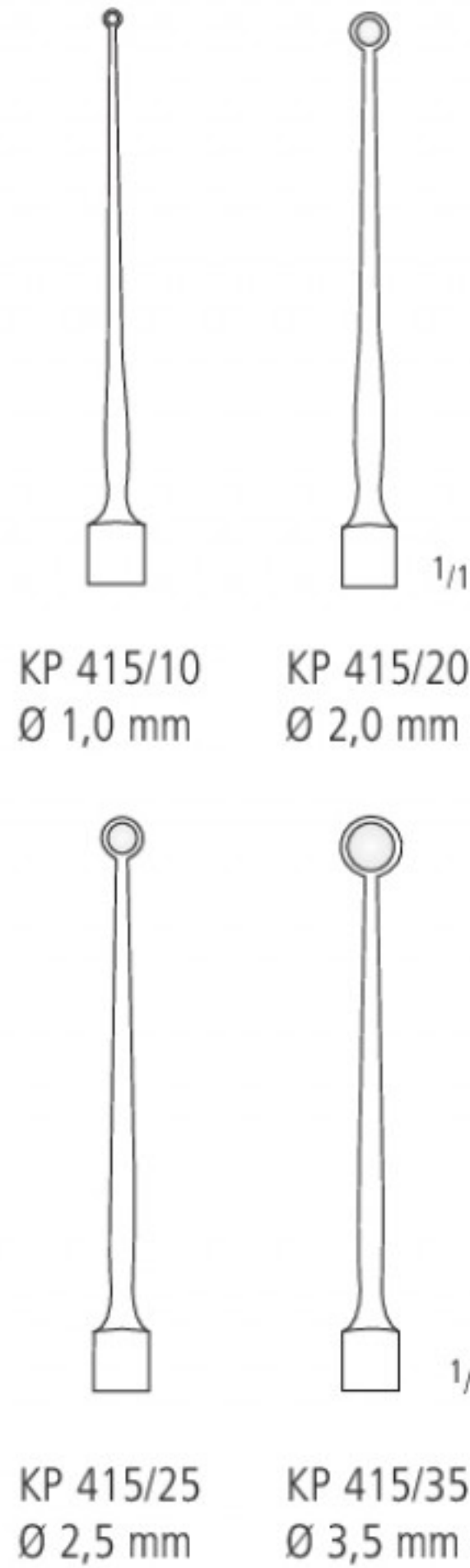

KP 415/10
Ø 1,0 mm

KP 415/20
Ø 2,0 mm

KP 415/25
Ø 2,5 mm

KP 415/35
Ø 3,5 mm

Set komplett
Set complete
Juego completo
Jeu complet
Set completo



BISHOP-HARMON
KP 700/00

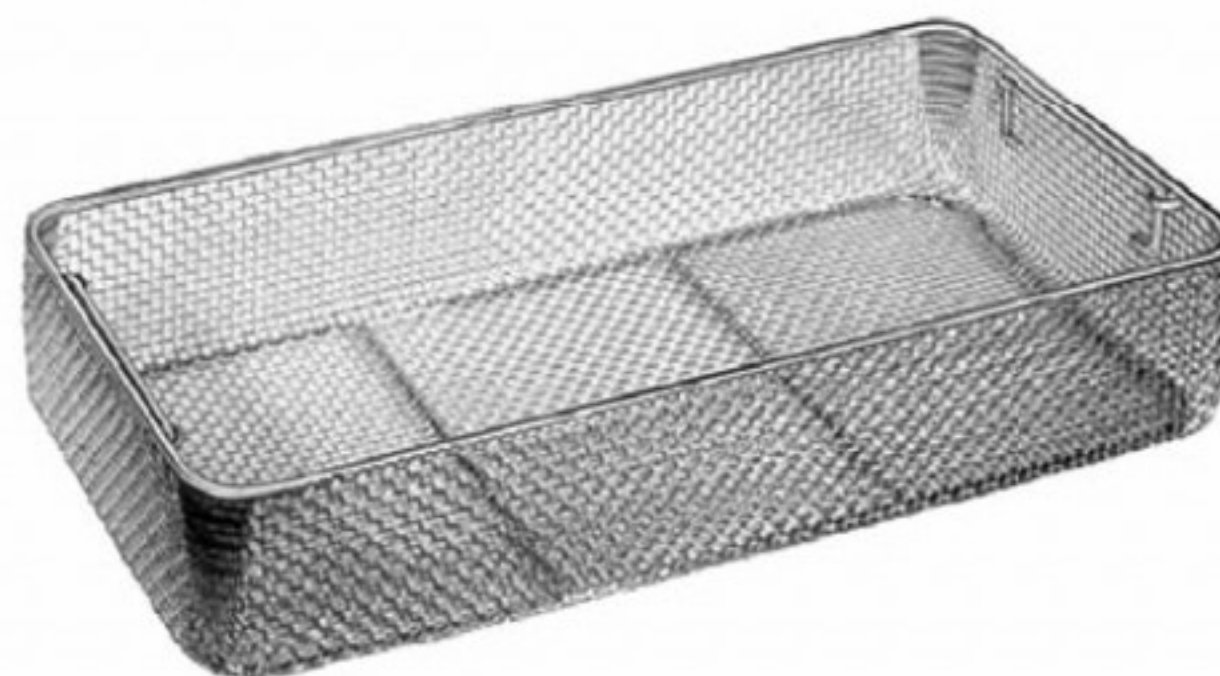

L(mm)	B(mm)	H(mm)	
485	255	50	SK 305/05

ZS 160/65 EMERGENCY SET

Contents:		Qty
AA 060/03	DIEFFENBACH BULLDOG CLAMPS STR 3,5 CM	2
AA 150/12	HALSTED-MOSQUITO FCPS STR 12,5 CM	2
AA 151/12	HALSTED-MOSQUITO FCPS CVD 12,5 CM	2
AA 711/09	JONES TOWEL FORCEPS 9,0 CM	2
AB 710/10	GRAEFE IRIS FORCEPS STR SERR. 10,0 CM	1
AB 734/01	BONN IRIS FORCEPS W.GUIDE PIN 1X2T. 7,0 CM	1
AB 738/08	BISHOP-HARMAN IRIS FORCEPS 1X2 T. 8,5 CM	1
AB 750/07	BARRAQUER-KATZIN FIX.FCPS 1X2 T. 7,0 CM	1
AB 796/02	LESTER FIXATION FORCEPS 1X2 TEETH 9,0 CM	1
AB 816/01	CASTROVIEJO SUTURE FORCEPS 0,12 MM 10,0 CM	2
AB 820/10	KELMAN-MCPHERSON TYING FORCEPS 10,0 CM	1
AB 828/10	PAUFIQUE SUTURE FORCEPS 1X2 TEETH 10,0 CM	1
AC 431/08	MOD.BONN SCISSORS CVD 8,0 CM	1
AC 466/10	IRIS SCISSORS STR W LARGE BOWS 10,0 CM	1
AC 475/11	STEVENS TENOTOM.SCS.CVD POINTED 11,5 CM	1
AC 768/05	BARRAQUER EYE SCISSORS 5,5 CM 5 MM	1
AC 782/11	WESTCOTT TENOTOMY SCISSORS BLUNT 11,0 CM	1
AC 797/01	WESTCOTT STRABISMUS SCS STR SHARP 11,5 CM	1
AD 540/00	RAZER BLADES, PACKING UNIT 10 PIECES	1
AD 550/09	BLADE BREAKER 9.0 CM DIA 5,5 MM	1
AE 600/10	BARRAQUER-TROUTMAN MICRO-NH STR RA 10,0 CM	1
AE 602/10	BARRAQUER-TROUTMAN MICRO-NH STR 10,0 CM	1
AE 660/14	CASTROVIEJO NH STR RA SMOOTH 14,0 CM	1
AK 090/10	DESMARRES RETRACTOR 10 MM 13,0 CM	1
AK 090/12	DESMARRES RETRACTOR 12 MM 13,0 CM	1
AK 090/14	DESMARRES RETRACTOR 14 MM 13,0 CM	1
AR 250/15	MEASURING INSTRUMENT 15,0 CM	1
AR 282/20	CASTROVIEJO CIRCLE 8,0 CM STRAIGHT	1
KP 002/12	JAMESON MUSCLE HOOK 12,0 CM	1
KP 010/14	GASS RETINAL DETACHMENT HOOK 14,0 CM	1
KP 015/02	GRAEFE STRABISMUS HOOK #2 14,0 CM	1
KP 018/12	STEVENS TENOTOMY HOOK 12,0 CM	1
KP 023/01	FIXATION HOOK RIGHT 11,0 CM	1
KP 150/05	BARRAQUER-COLIBRI EYE SPECULA 5,0 MM 3,0 CM	1
KP 150/10	BARRAQUER-COLIBRI EYE SPECULA 10,0 MM 3,0 CM	1
KP 154/04	BARRAQUER PHACO EYE SPECULA 4,0 CM	1
KP 212/08	LIEBERMAN EYE SPECULA 15,0 MM 8,0 CM	1
KP 280/14	SCHOCKET SCLERAL DEPRESSOR 14,0 CM	1
KP 542/01	SCHIOETZ TONOMETER STRAIGHT SCALE	1
KP 700/00	BISHOP-HARMON ANTERIOR CHAMBER	1
KP 731/27	SAUTTER AIR INJECTION CANNULA 27G 3,5 CM	1
SK 305/05	WIRE BASKET, 485 X 255 X 50 MM	1

Sterilization Container KYE 200/61, if required



Irispinzetten
Iris Forceps
Pinzas para iris
Pinces à iris
Pinze per iride

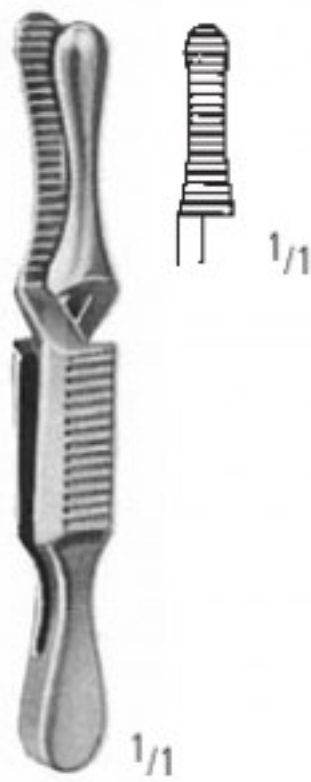

DIEFFENBACH
AA 060/03
3,5 cm/1 1/2"

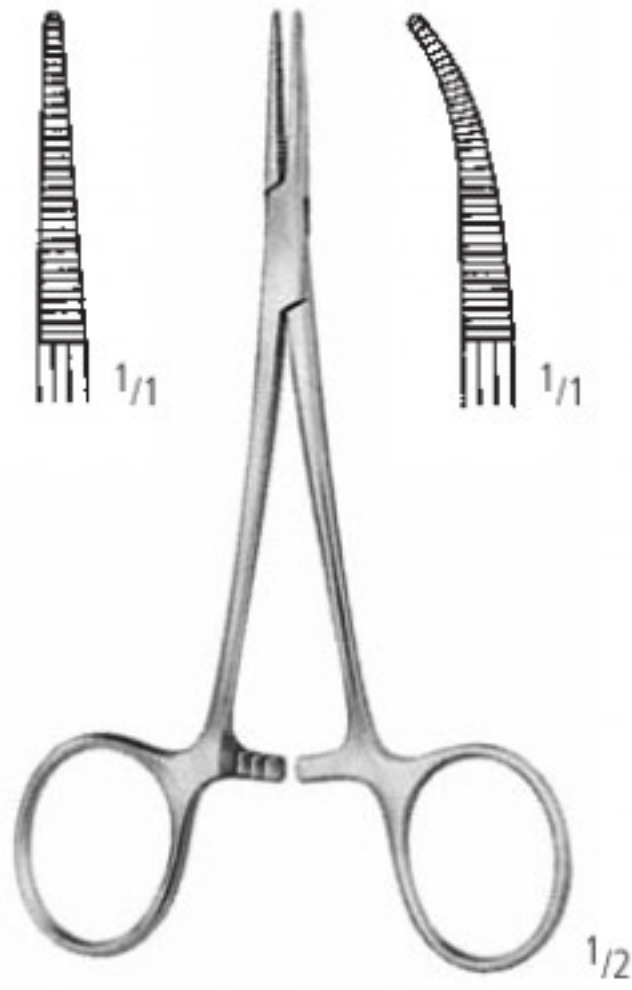

HALSTED-MOSQUITO
AA 150/12 AA 151/12
12,5 cm/5"



JONES
AA 711/09
9,0 cm/3 1/2"



GRAEFE
AB 710/10
10,0 cm/4"



MOD. BONN 1:2
AB 734/01
7,0 cm/2 3/4"



mit Führungstift
with guide pin
con espiga de guía
avec repères
con perno da guida



BISHOP-HARMAN 1:2
AB 738/08
8,5 cm/3 1/3"

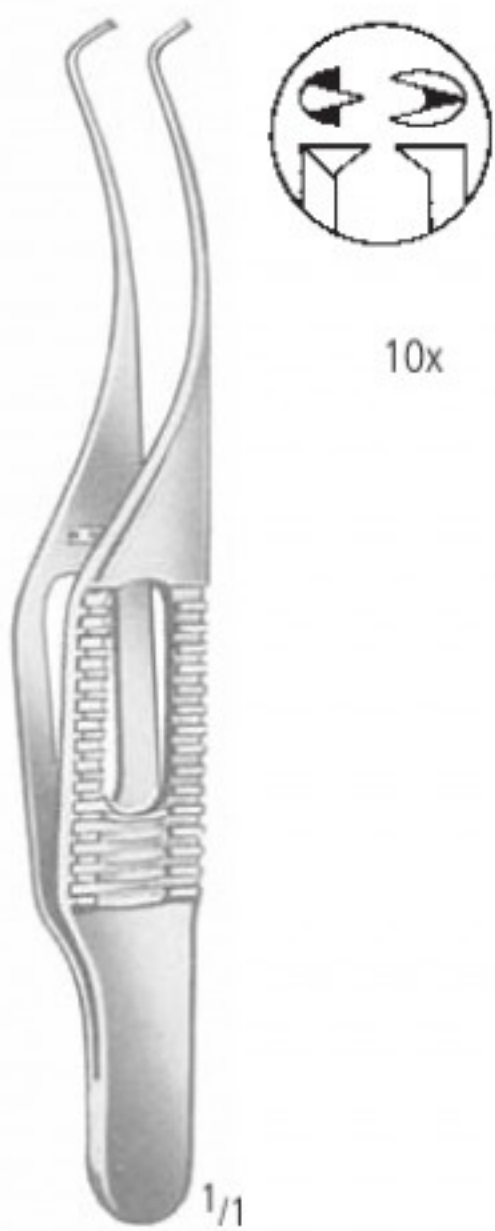

BARRAQUER-KATZIN 1:2
(Colibri)
AB 750/07
7,0 cm/2 3/4"



LESTER
AB 796/02
9,0 cm/3 1/2"



CASTROVIEJO 1:2
AB 816/01
0,12 mm
10,0 cm/4"

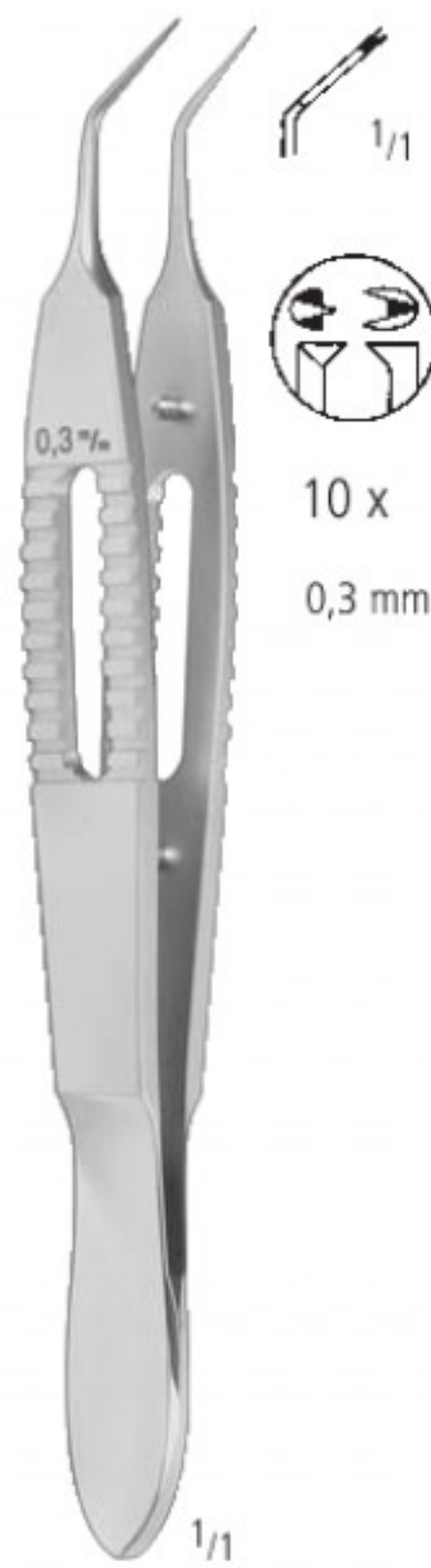

KELMAN-McPHERSON 1:2
AB 820/10
10,0 cm/4"

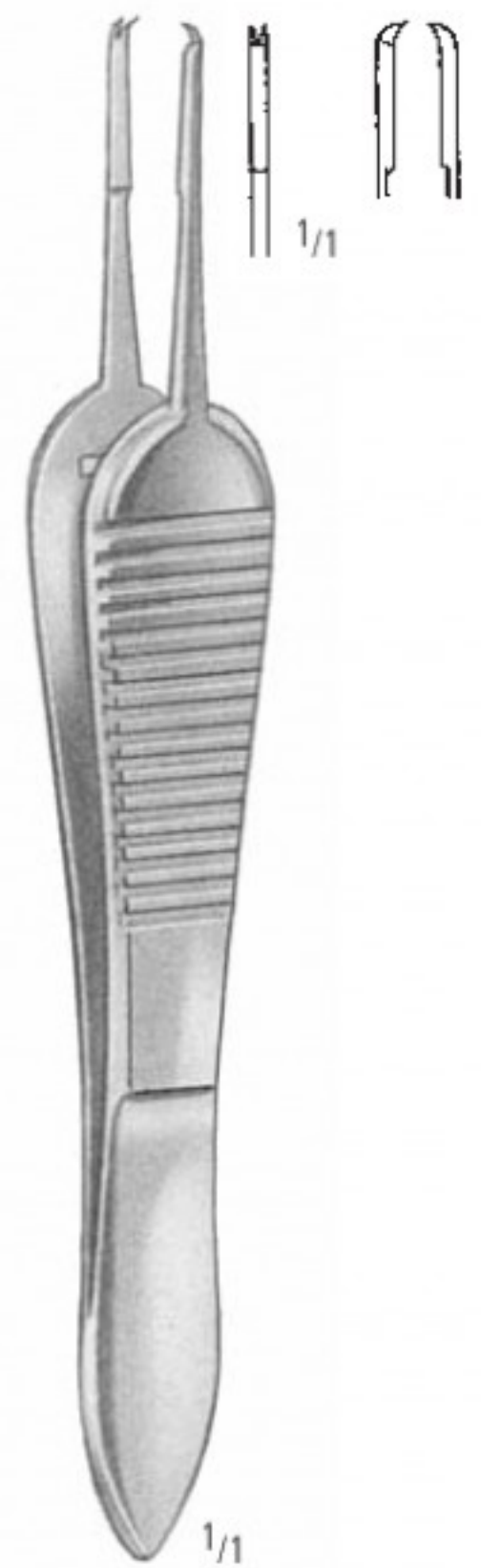

PAUFIGUE 1:2
AB 828/10
10,0 cm/4"

mit großen Ringen
with large bows
con anillos grandes
avec grands anneaux
con anelli grandi

Sehnenscheren
Tenotomy Scissors
Tijeras para tenotomía
Ciseaux à ténatomie
Forbici per tenotomia

spitz
pointed
agudas
pointues
acuta

gebogen
curved
curvas
courbes
curve

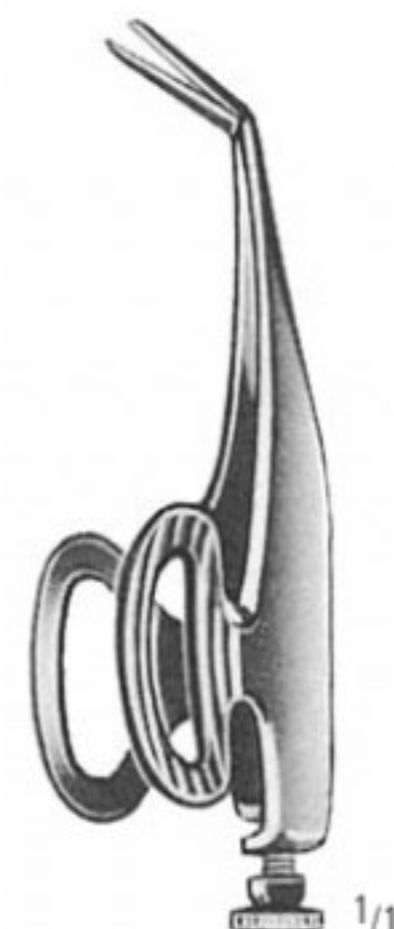
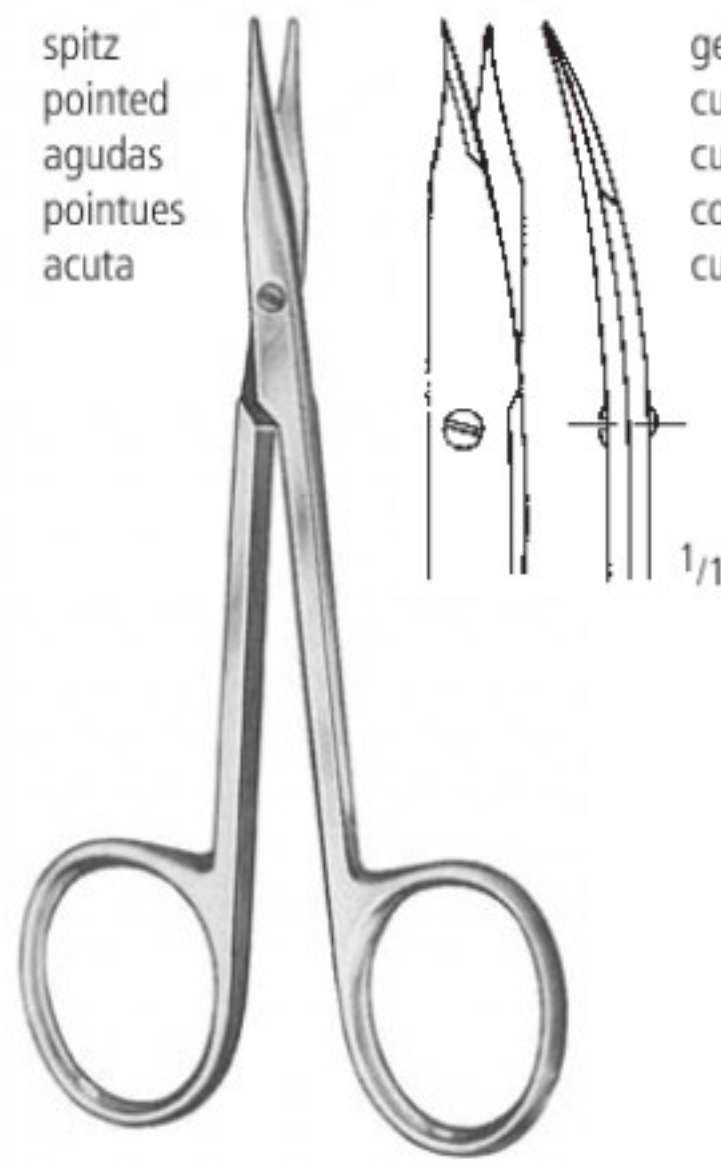
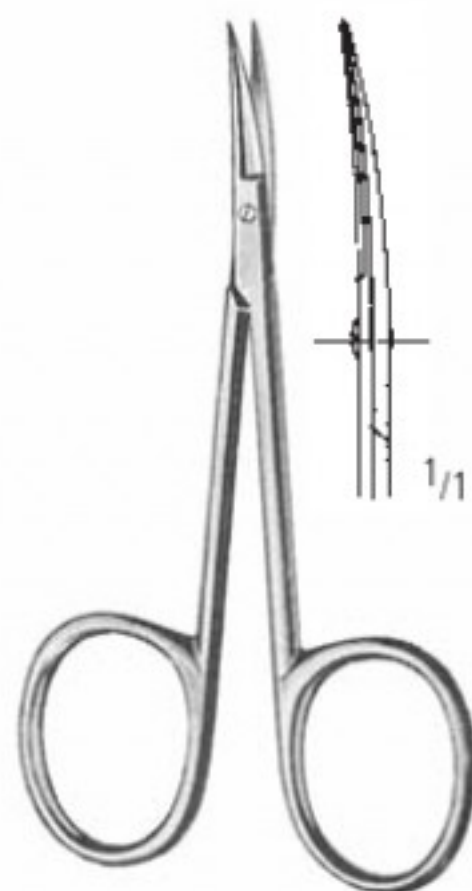

MOD. BONN
AC 431/08
8,0 cm/3"

AC 466/10
10,0 cm/4"

STEVENS
AC 475/11
11,5 cm/4 1/2"

BARRAQUER
5,5 cm/2 1/4"
5 mm AC 768/05

RASIERKLINGEN, VERPACKUNGSEINHEIT 10 STCK
RAZOR BLADES, PACKING UNIT 10 PIECES
HOJAS DE AFEITAR, UNIDAD DE VENTA 10 PZ
LAMES DE RASOIR, UNITÉ À 10 PIÈCES
LAMETTE DA BARBA, UNITÀ DI VENDITA 10 PZ

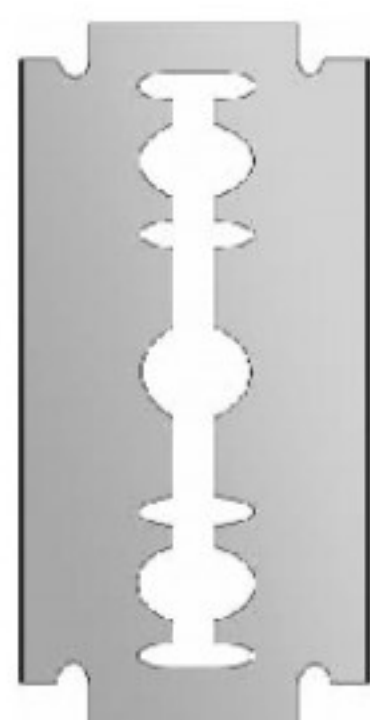

AD 540/00

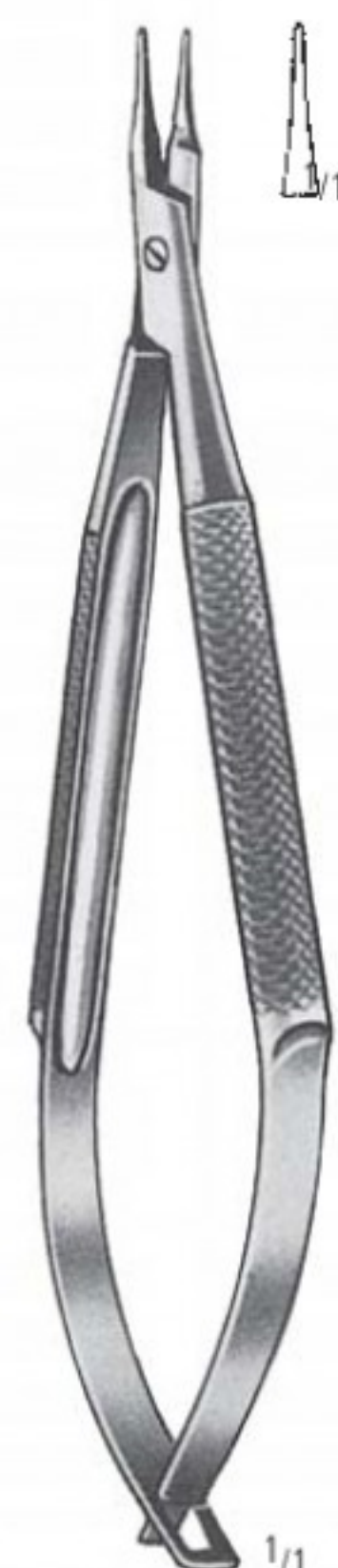

WESTCOTT
AC 782/11
11,0 cm/4 1/3"

WESTCOTT
AC 797/01
11,5 cm/4 1/2"

TROUTMAN-CHRIS
AD 550/09
Ø 5,5 mm
9,0 cm/3 1/2"

BARRAQUER-TROUTMAN
AE 600/10
10,0 cm/4"

BARRAQUER-TROUTMAN
AE 602/10
10,0 cm/4"

CASTROVIEJO
AE 660/14
14,0 cm/5 1/2"



DESMARRES
13,0 cm/5"

AK 090/10
10 mm

AK 090/12
12 mm

AK 090/14
14 mm



Messbereich 20 mm
measuring range 20 mm
campo de medición 20 mm
étendue de mesurage 20 mm
ampiezza di misura 20 mm



CASTROVIEJO
AR 282/20
8,0 cm/ 3"



JAMESON
KP 002/12
12,0 cm/4³/₄"

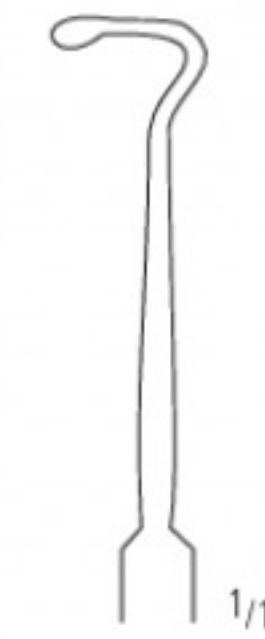

GASS
KP 010/14
14,0 cm/5¹/₂"

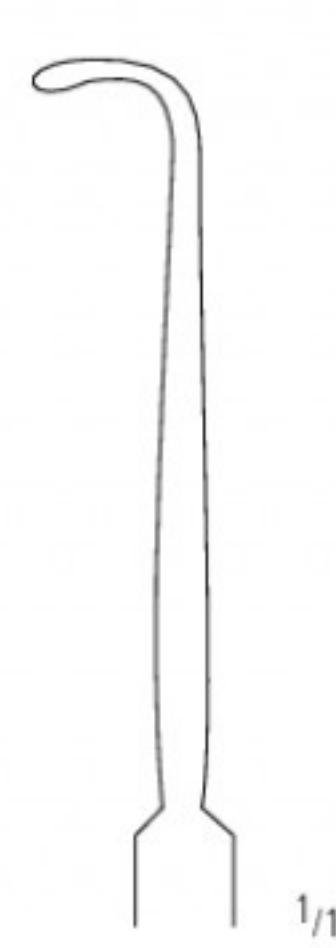

GRAEFE
KP 015/02
14,0 cm/5¹/₂"
Fig. 2

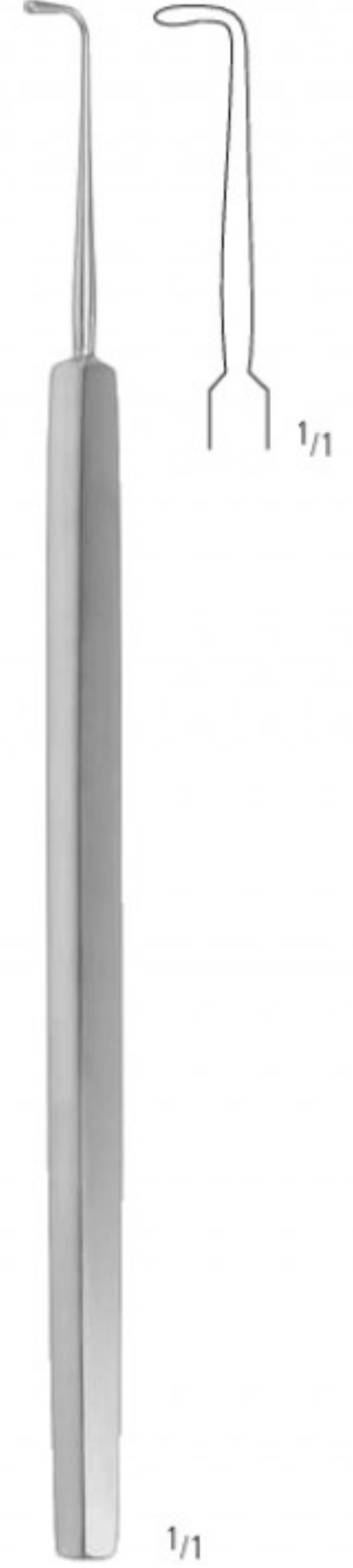

STEVENS
KP 018/12
12,0 cm/4³/₄"

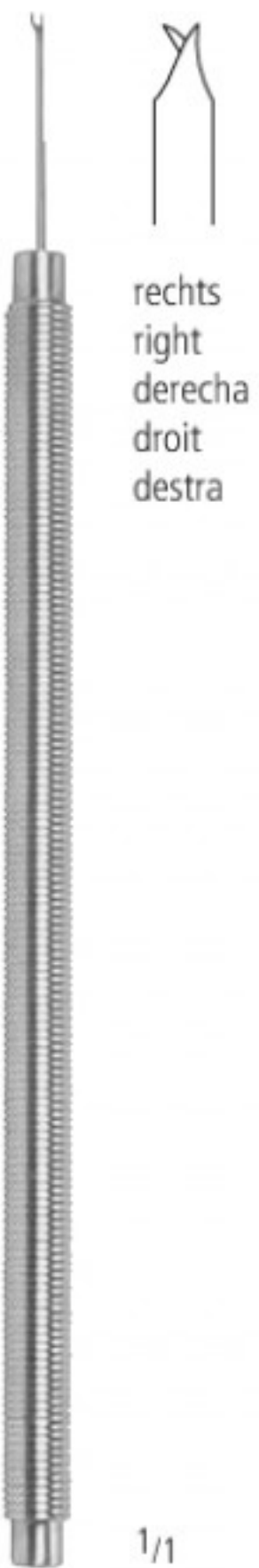

rechts
right
derecha
droit
destra

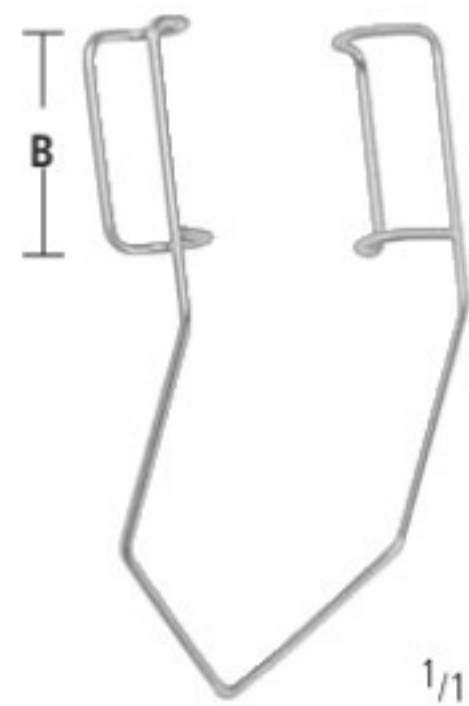

BARRAQUER-COLIBRI
B
5 mm KP 150/05
3,0 cm/1¹/₄"

Frühgeborene
Premature infant
Parto prematuro
Accouchement prématuré
Parto prematuro

10 mm KP 150/10
3,0 cm/1¹/₄"

Kind
Child
Niños
Enfants
Bambini

KP 023/01
11,0 cm/4¹/₂"



BARRAQUER PHAKO
KP 154/04
4,0 cm/1¹/₂"



LIEBERMAN
KP 212/08
8,0 cm/3¹/₄"
B = 15 mm

ZS 160/65 EMERGENCY SET



1/1

SCHOCKET
KP 280/14
14,0 cm/5 1/2"



gerade Skala
straight scale
graduado recto
échelle droite
scala retta

SCHIOETZ
KP 542/01
13,0 cm/5"

Spezifikation Nr. 5, geeicht
Specification No. 5, calibrated
Especificación No. 5, calibrada
Spécification No. 5, calibrée
Specifica No. 5, calibrata

Set komplett
Set complete
Juego completo
Jeu complet
Set completo



1/2

BISHOP-HARMON
KP 700/00

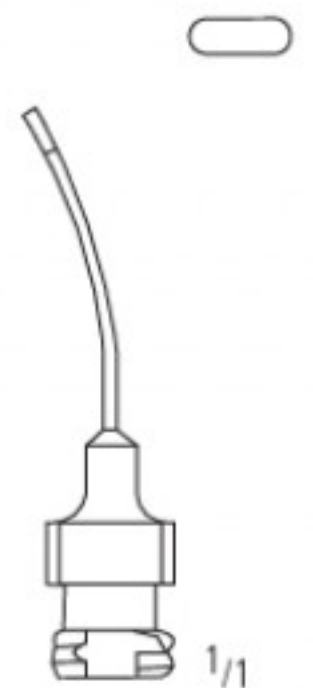

1/1

SAUTTER
KP 731/27
3,5 cm/1 1/2"
27G

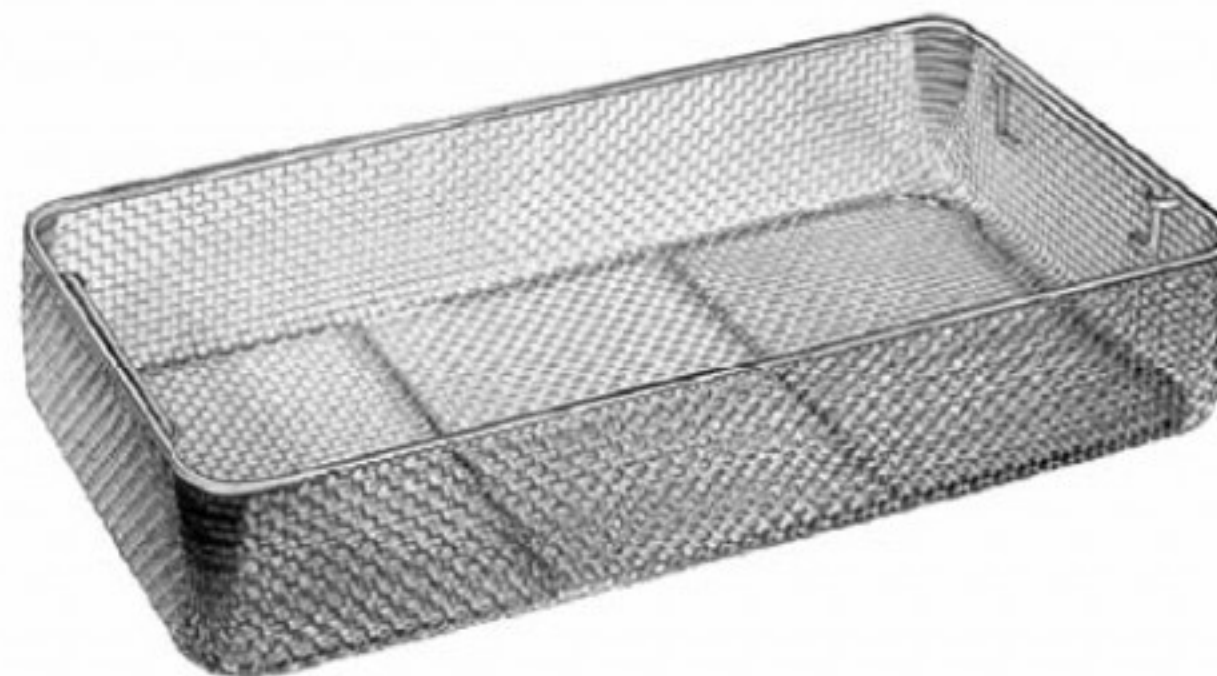

L(mm) B(mm) H(mm)

485 255 50 SK 305/05

ZS 160/70 PTERYGIUM SET

Contents:		Qty
AB 710/10	GRAEFE IRIS FORCEPS STR SERR. 10,0 CM	1
AB 714/10	GRAEFE IRIS FORCEPS STR 1X2 TEETH 10,0 CM	1
AB 786/02	GREEN FIXATION FORCEPS T-FORM 10,0 CM	1
AB 828/10	PAUFIQUE SUTURE FORCEPS 1X2 TEETH 10,0 CM	1
AC 466/10	IRIS SCISSORS STR W LARGE BOWS 10,0 CM	1
AE 657/14	CASTROVIEJO NH CVD SMOOTH 14,0 CM	1
AK 090/10	DESMARRES RETRACTOR 10 MM 13,0 CM	1
KP 186/08	LANCASTER EYE SPECULA 8,0 CM	1
KP 325/05	BONN SCLERA KNIFE 5MM 12,5 CM	1
SK 105/05	WIRE BASKET, 255 X 245 X 50 MM	

Sterilization Container KYE 200/11, if required



ZS 160/70 PTERYGIUM SET



AB 710/10
10,0 cm/4"

GRAEFE



AB 714/10
10,0 cm/4"

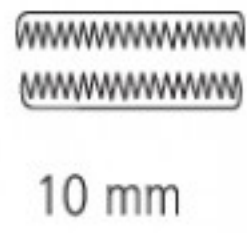

GREEN
AB 786/02
10,0 cm/4"

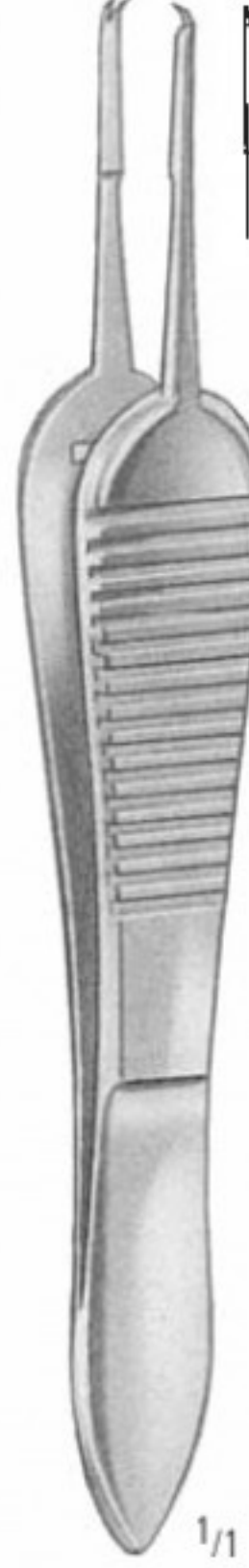

PAUFIGUE 1:2
AB 828/10
10,0 cm/4"

mit großen Ringen
with large bows
con anillos grandes
avec grands anneaux
con anelli grandi



AC 466/10
10,0 cm/4"



CASTROVIEJO
AE 657/14
14,0 cm/5 1/2"



DESMARRES
AK 090/10
13,0 cm/5"



LANCASTER
KP 186/08
8,0 cm/3 1/4"

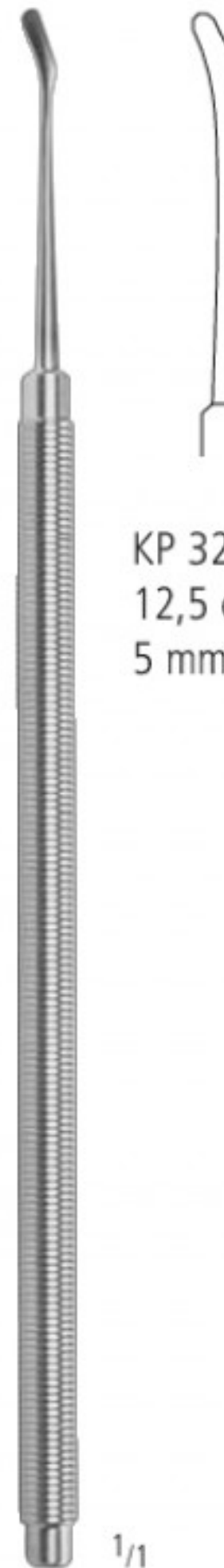

BONN

KP 325/05
12,5 cm/ 5"
5 mm



L(mm)	B(mm)	H(mm)	
255	245	50	SK 105/05

ZS 160/75 RADIALE KERATOTOMY RK SET

Contents:		Qty
AB 752/07	BARRAQUER-KATZIN IRIS FORCEPS 7,0 CM	1
AB 820/10	KELMAN-MCPHERSON TYING FORCEPS 10,0 CM	1
KP 154/04	BARRAQUER PHACO EYE SPECULA 4,0 CM	1
KP 375/02	PREMIUM DIAMOND KNIFE 1,0 CM 45°	1
KP 500/30	HOFFER OPTICAL ZONE MARKER 3,00 MM 10,0 CM	1
KP 500/32	HOFFER OPTICAL ZONE MARKER 3,25 MM 10,0 CM	1
KP 500/40	HOFFER OPTICAL ZONE MARKER 4.00 MM 10,0 CM	1
KP 500/50	HOFFER OPTICAL ZONE MARKER 5.00MM 10,0 CM	1
KP 500/70	HOFFER OPTICAL ZONE MARKER 7.00MM 10,0 CM	1
KP 535/12	ANIS SUTURE PLACEMENT MARKER 8 BLADES	1
KP 548/50	DEITZ DEPTH GAUGE 0,50 MM 9,5 CM	1
KP 548/55	DEITZ DEPTH GAUGE 0,55 MM 9,5 CM	1
KP 550/12	THORNTON FIXATION RING FG-HINGE Ø 13,0 MM	1
KP 731/27	SAUTTER AIR INJECTION CANNULA 27G 3,5 CM	2
SK 105/05	WIRE BASKET, 255 X 245 X 50 MM	1

Sterilization Container KYE 200/11, if required



ZS 160/75 RADIALE KERATOTOMY RK SET



BARRAQUER-KATZIN 1:2 (Colibri)
AB 752/07
7,0 cm/2³/₄"

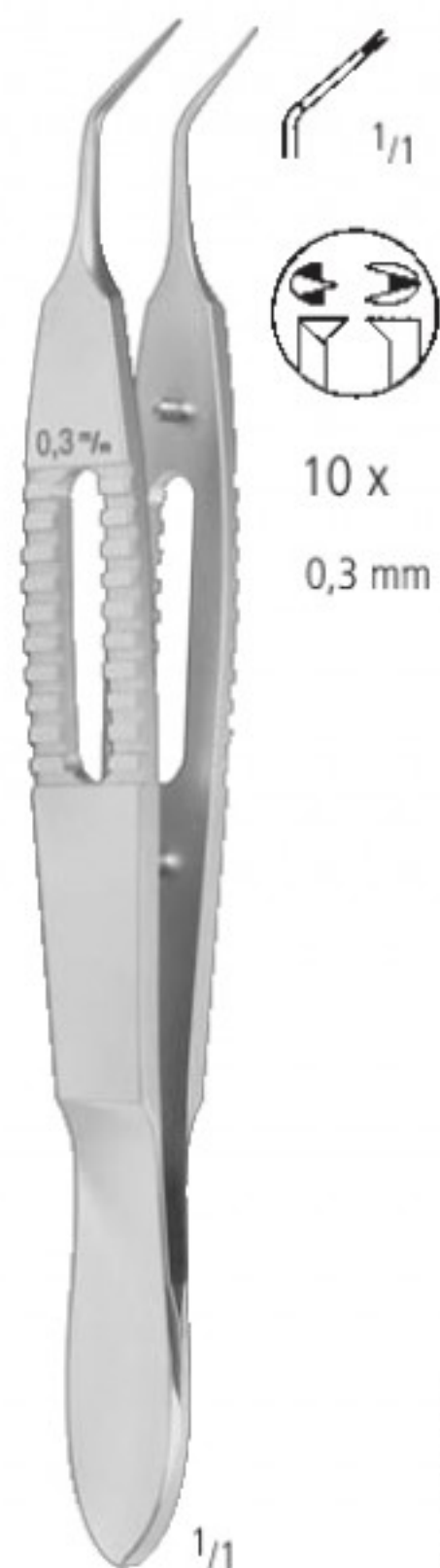

BARRAQUER PHAKO
KP 154/04
4,0 cm/1¹/₂"



mit Mikrometer
with micrometer
con micrómetro
avec micromètre
con micrometro

- Ø 3,00 mm
- Ø 3,25 mm
- Ø 4,00 mm
- Ø 5,00 mm
- Ø 7,00 mm



HOFFER
10,0 cm/4"

KELMAN-McPHERSON 1:2
AB 820/10
10,0 cm/4"

KP 375/02



ANIS
KP 535/12
12,0 cm/4³/₄"



DEITZ
9,5 cm/3³/₄"
KP 548/50 0,50 mm
KP 548/55 0,55 mm

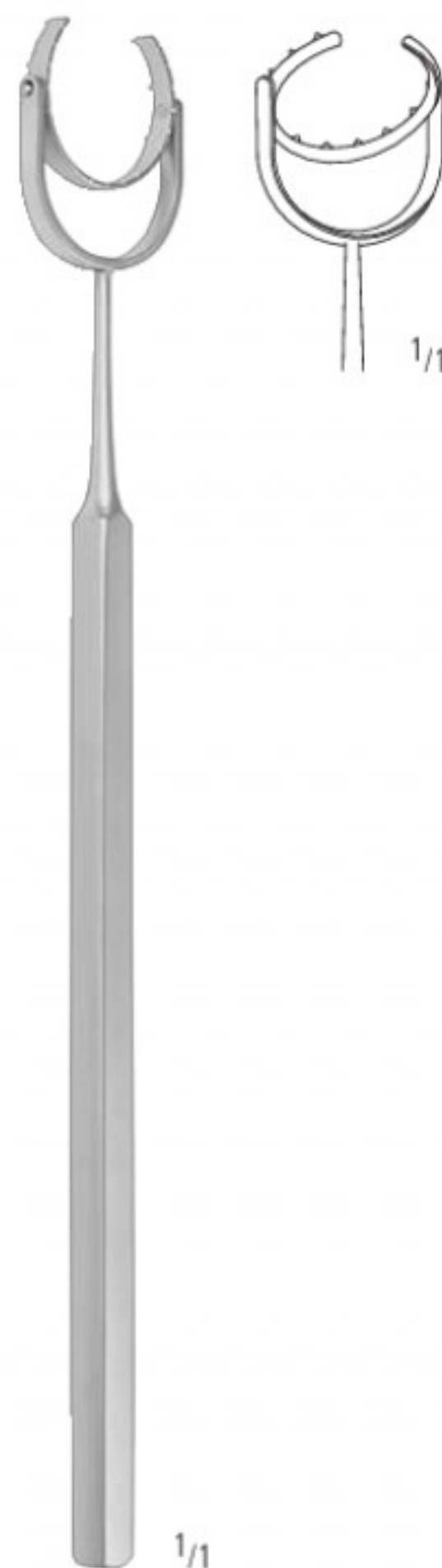

THORNTON
KP 550/12
12,0 cm/4³/₄"
Ø 13 mm

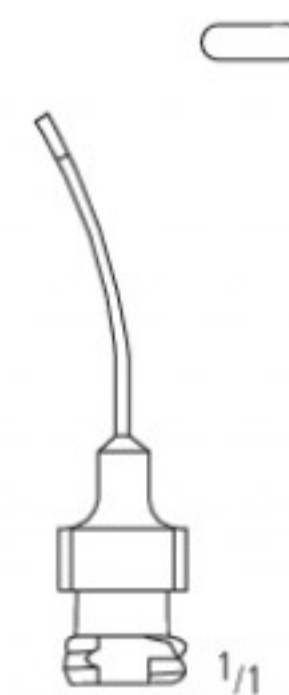

SAUTER
KP 731/27
3,5 cm/1¹/₂"
27G



L(mm)	B(mm)	H(mm)	
255	245	50	SK 105/05

ZS 160/80 STRABISMUS / MUSCLE SET

Contents:		Qty
AA 060/03	DIEFFENBACH BULLDOG CLAMPS STR 3,5 CM	1
AA 114/10	HARTMANN FORCEPS STR 10,0 CM	1
AA 751/13	BACKHAUS TOWEL FORCEPS 13,0 CM	1
AB 734/01	BONN IRIS FORCEPS W.GUIDE PIN 1X2T. 7,0 CM	1
AB 816/01	CASTROVIEJO SUTURE FORCEPS 10,0 CM	2
AB 828/10	PAUFIQUE SUTURE FORCEPS 1X2 TEETH 10,0 CM	1
AB 835/09	BERENS MUSCLE CLAMP 8,5 CM 5 TEETH WITH	1
AC 450/10	IRIS SCISSORS STR SH/SH 10,5 CM	1
AC 475/11	STEVENS TENOTOM.SCS.CVD POINTED 11,5 CM	1
AC 780/11	WESTCOTT TENOTOMY SCS. POINTED 11,0 CM	1
AC 797/01	WESTCOTT STRABISMUS SCS STR SHARP 11,5 CM	1
AE 660/14	CASTROVIEJO NH STR RA SMOOTH 14,0 CM	1
AE 661/14	CASTROVIEJO NH CVD RA SMOOTH 14,0 CM	1
AR 282/20	CASTROVIEJO CIRCLE 8,0 CM STRAIGHT	1
KP 001/13	GREEN STRABISMUS HOOK 13,0 CM	1
KP 010/14	GASS RETINAL DETACHMENT HOOK 14,0 CM	1
KP 015/01	GRAEFE STRABISMUS HOOK #1 13,0 CM	1
KP 015/02	GRAEFE STRABISMUS HOOK #2 14,0 CM	1
KP 015/03	GRAEFE STRABISMUS HOOK #3 15,0 CM	1
KP 018/12	STEVENS TENOTOMY HOOK 12,0 CM	1
KP 175/09	CASTROVIEJO EYE SPECULA 16,0 MM 9,0 CM	1
KP 262/13	ARRUGA PROTECTOR 13,0 CM	1
KP 540/13	GONNIN AMSLER MARKER 11-23 MM / 1 MM	1
KP 700/00	BISHOP-HARMON ANTERIOR CHAMBER	1
SK 105/05	WIRE BASKET, 255 X 245 X 50 MM	1

Sterilization Container KYE 200/11, if required



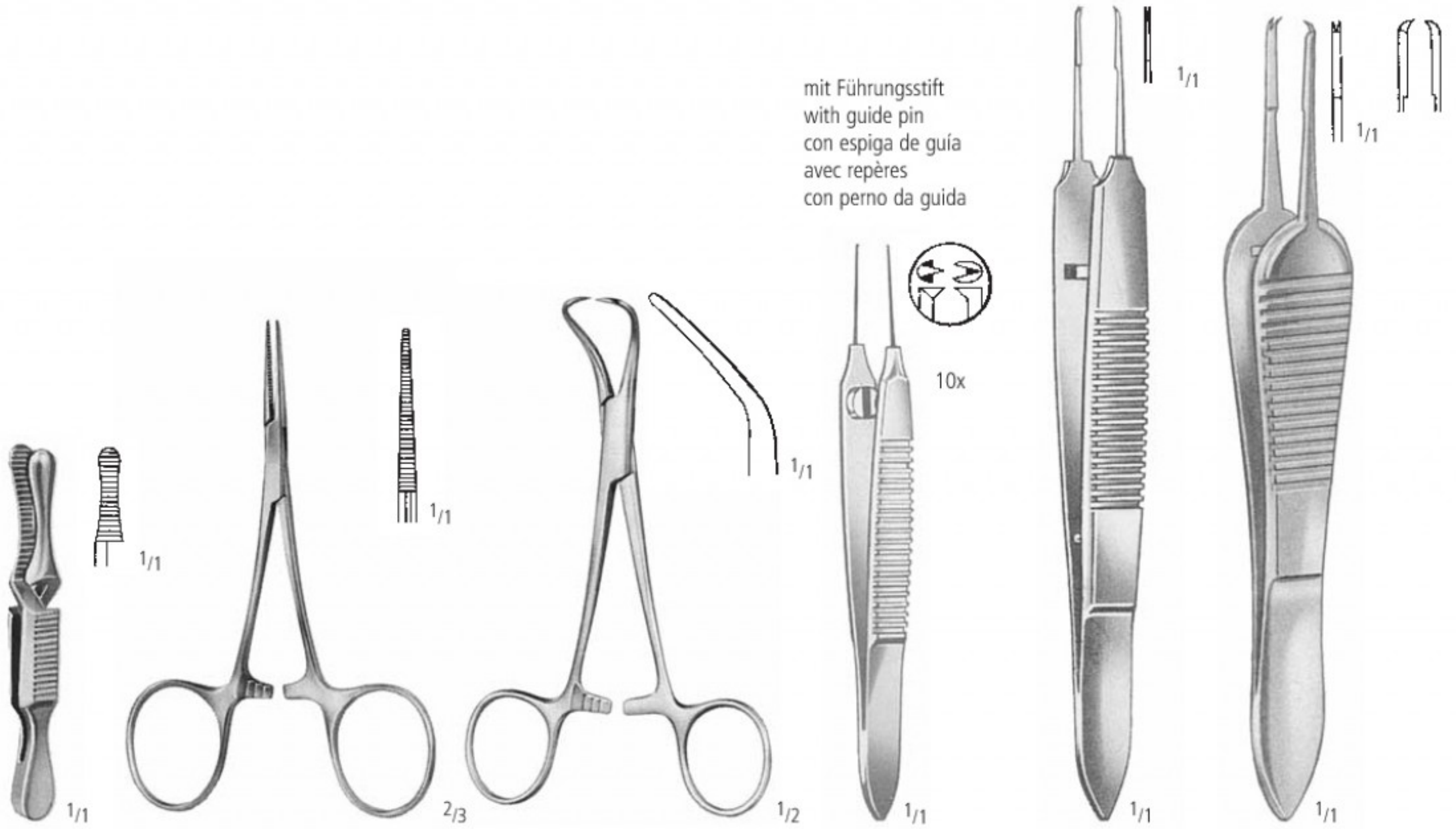

mit Führungsstift
with guide pin
con espiga de guía
avec repères
con perno da guida

10x

DIEFFENBACH
AA 060/03
3,5 cm/1 1/2"

HARTMANN
AA 114/10
10,0 cm/4"

BACKHAUS
AA 751/13
13,0 cm/5"

MOD. BONN 1:2
AB 734/01
7,0 cm/2 3/4"

CASTROVIEJO 1:2
AB 816/01
0,12 mm
10,0 cm/4"

PAUFIQUE 1:2
AB 828/10
10,0 cm/4"

Irisscheren
Iris Scissors
Tijeras para iridectomía
Ciseaux à iridectomie
Forbici per iridectomia

Sehnenscheren
Tenotomy Scissors
Tijeras para tenotomía
Ciseaux à ténotomie
Forbici per tenotomia

spitz
pointed
agudas
pointues
acuta

gebogen
curved
curvas
courbes
curve

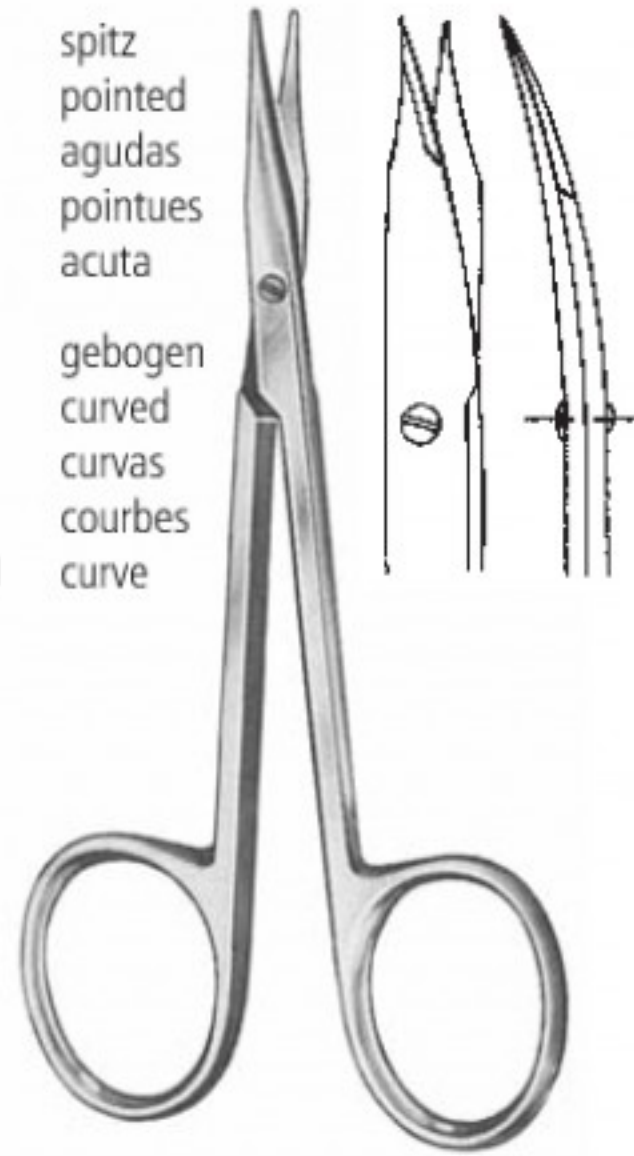
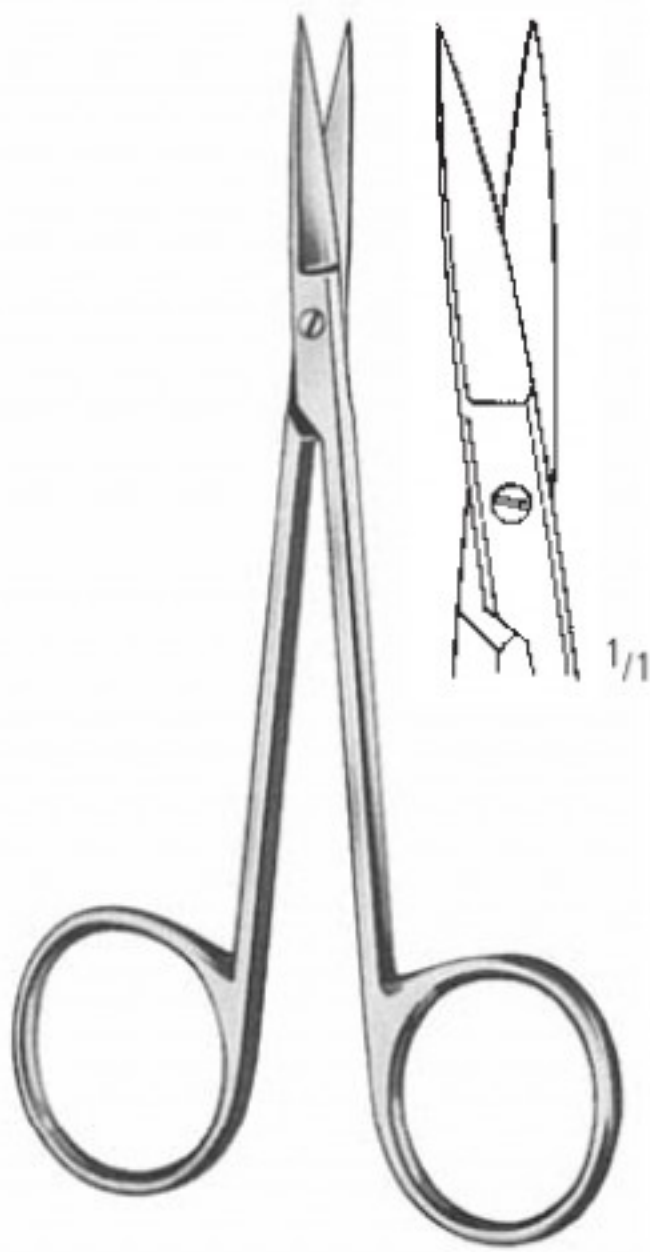

BERENS
AB 835/09
8,5 cm/3 1/3"

AC 450/10
10,5 cm/4 1/4"

STEVENS
AC 475/11
11,5 cm/4 1/2"

WESTCOTT
AC 780/11
11,0 cm/4 1/3"

WESTCOTT
AC 797/01
11,5 cm/4 1/2"

CASTROVIEJO
14,0 cm/5 1/2"

AE 660/14

AE 661/14

Messbereich 20 mm
 measuring range 20 mm
 campo de medición 20 mm
 étendue de mesurage 20 mm
 ampiezza di misura 20 mm



CASTROVIEJO
 AR 282/20
 8,0 cm/ 3"



GREEN
 KP 001/13
 13,0 cm/5"



GASS
 KP 010/14
 14,0 cm/5 1/2"

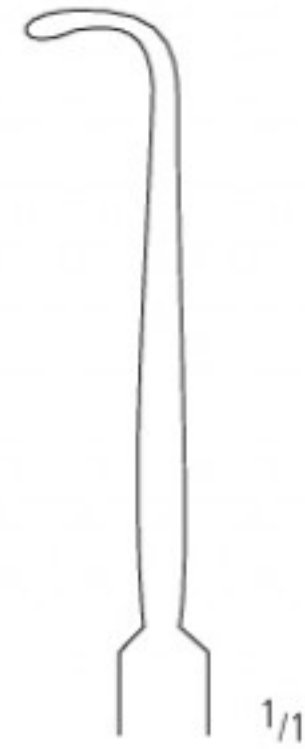

GRAEFE
 KP 015/01
 13,0 cm/5"
 Fig. 1

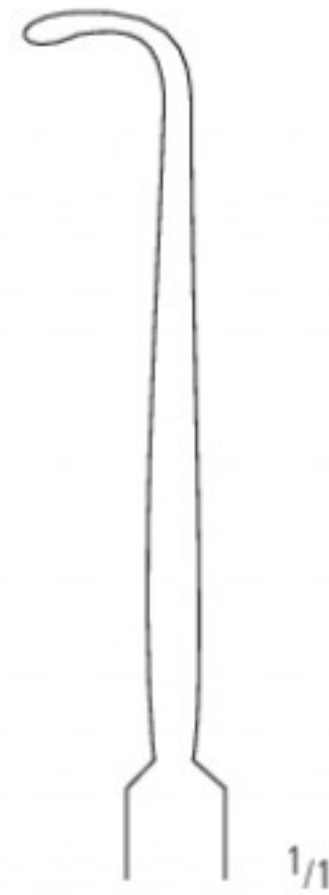

GRAEFE
 KP 015/02
 14,0 cm/5 1/2"
 Fig. 2

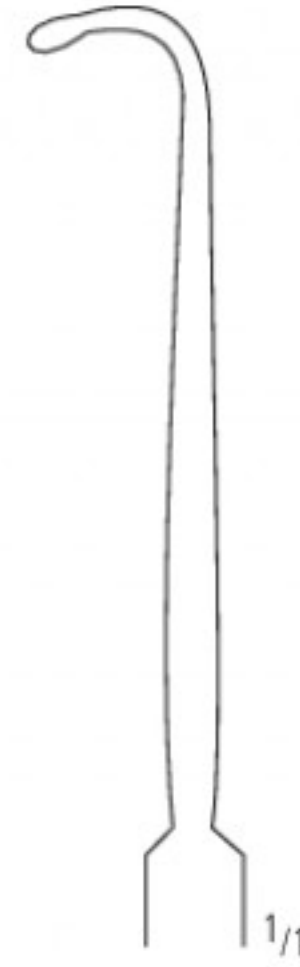

GRAEFE
 KP 015/03
 15,0 cm/6"
 Fig. 3



STEVENS
 KP 018/12
 12,0 cm/4 3/4"



CASTROVIEJO
 KP 175/09
 9,0 cm/3 1/2"
B = 16 mm



1/1

ARRUGA
KP 262/13
13,0 cm/5"



1/1

GONNIN
KP 540/13
13,0 cm/5"
11-23 mm / 1 mm



1/2

BISHOP-HARMON
KP 700/00

Set komplett
Set complete
Juego completo
Jeu complet
Set completo



L(mm)	B(mm)	H(mm)	
255	245	50	SK 105/05

ZS 160/85 VITRECTOMY -PARS PLANA- SET

Contents:		Qty
AA 060/03	DIEFFENBACH BULLDOG CLAMPS STR 3,5 CM	2
AA 114/10	HARTMANN FORCEPS STR 10,0 CM	2
AA 150/12	HALSTED-MOSQUITO FCPS STR 12,5 CM	2
AA 711/09	JONES TOWEL FORCEPS 9,0 CM	2
AA 751/13	BACKHAUS TOWEL FORCEPS 13,0 CM	2
AB 710/10	GRAEFE IRIS FORCEPS STR SERR. 10,0 CM	1
AB 750/07	BARRAQUER-KATZIN FIX.FCPS 1X2 T. 7,0 CM	1
AB 816/01	CASTROVIEJO SUTURE FORCEPS 10,0 CM	2
AB 824/02	BONACCOLTO SUTURE FORCEPS 10,0 CM FINE	1
AB 825/02	BONN SUTURE FORCEPS 10,0 CM ULRTA FINE	2
AB 848/11	FAULKNER LENS HOLDING FORCEPS 11,0 CM	1
AC 466/10	IRIS SCISSORS STR W LARGE BOWS 10,0 CM	1
AC 467/10	IRIS SCISSORS CVD W LARGE BOWS 10,0 CM	1
AC 474/11	STEVENS TENOTOM.SCS.STR POINTED 11,5 CM	1
AC 776/01	VANNAS MOD.TÜBINGEN STRAIGHT 8,5 CM	1
AC 780/11	WESTCOTT TENOTOMY SCS.POINTED 11,0 CM	1
AE 657/14	CASTROVIEJO NH CVD SMOOTH 14,0 CM	1
AE 660/14	CASTROVIEJO NH STR RA SMOOTH 14,0 CM	1
AR 282/20	CASTROVIEJO CIRCLE 8,0 CM STRAIGHT	1
KP 002/12	JAMESON MUSCLE HOOK 12,0 CM	2
KP 010/14	GASS RETINAL DETACHMENT HOOK 14,0 CM	2
KP 211/08	LIEBERMAN EYE SPECULA 15 MM 8,0 CM ASP.	1
KP 261/15	SAUTTER ORBITAL SPATUL MEDIUM 15,0 CM	1
KP 262/13	ARRUGA PROTECTOR 13,0 CM	1
KP 354/12	FOREIGN BODY NEEDLE STRAIGHT 12,0 CM	1
KP 390/00	VITRECTOMY SCISSORS STRAIGHT SMOOTH 0°	1
KP 394/00	VITRECTOMY GRASPING FCPS STRAIGHT SMOOTH	1
KP 700/00	BISHOP-HARMON ANTERIOR CHAMBER	1
KP 760/21	INJECTION CANNULA 21G 4,5 CM	1
SK 305/05	WIRE BASKET, 485 X 255 X 50 MM	1

Sterilization Container KYE 200/61, if required



ZS 160/85 VITRECTOMY -PARS PLANA- SET



DIEFFENBACH
AA 060/03
3,5 cm/1 1/2"

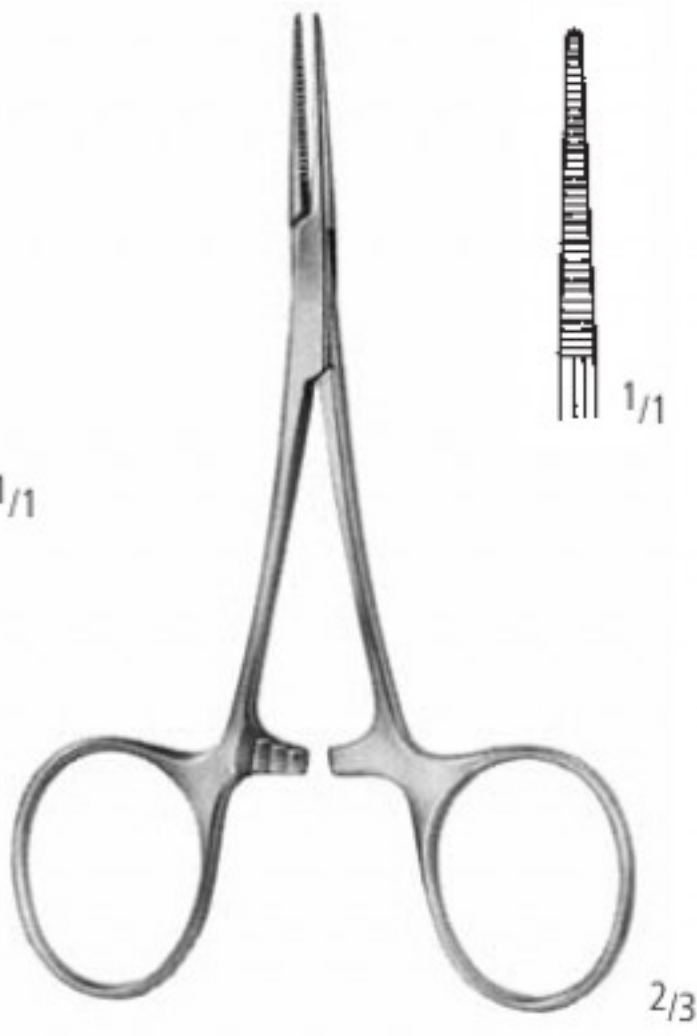

HARTMANN
AA 114/10
10,0 cm/4"



HALSTED-MOSQUITO
AA 150/12
12,5 cm/5"



JONES
AA 711/09
9,0 cm/3 1/2"

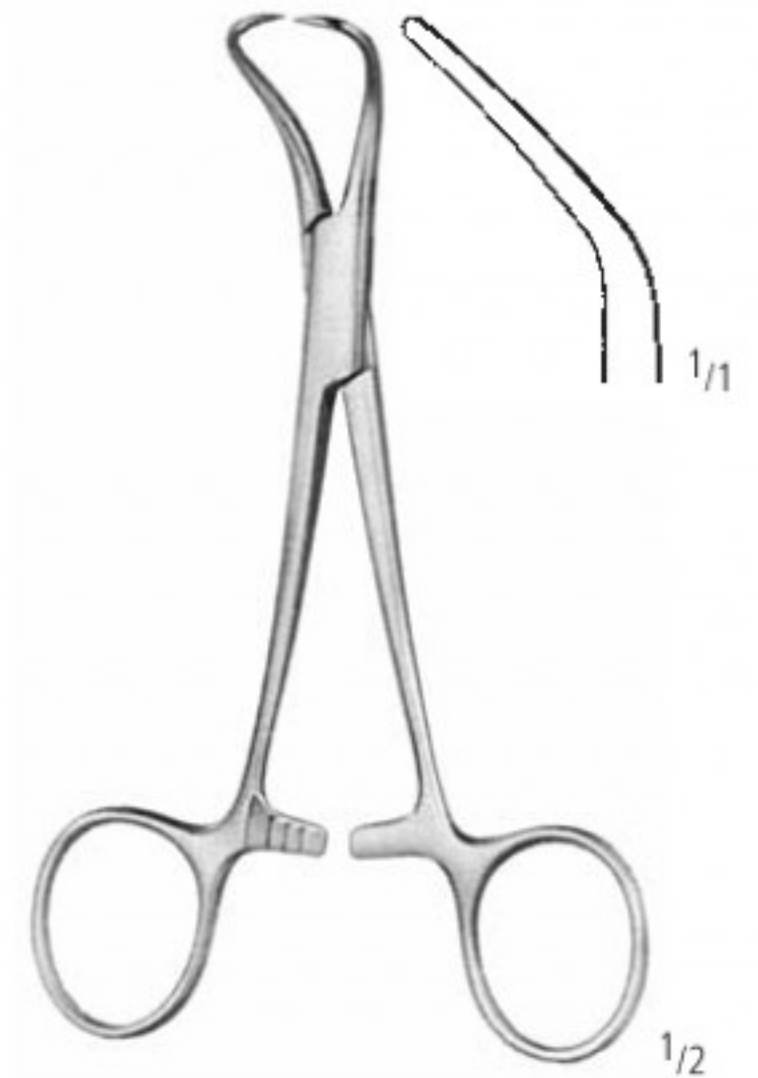

BACKHAUS
AA 751/13
13,0 cm/5"

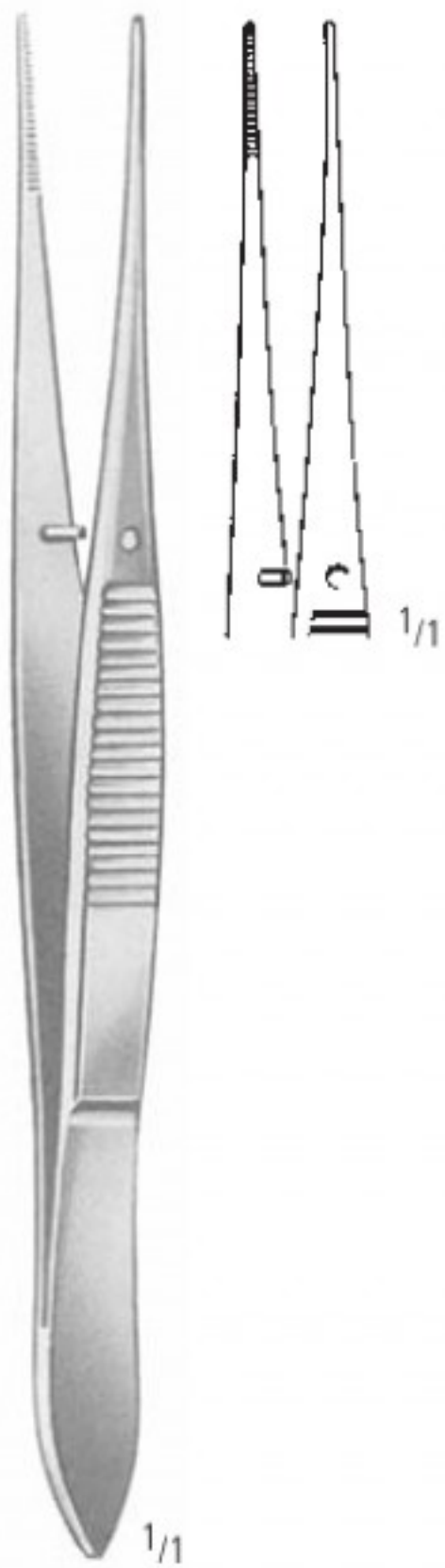

GRAEFE
AB 710/10
10,0 cm/4"

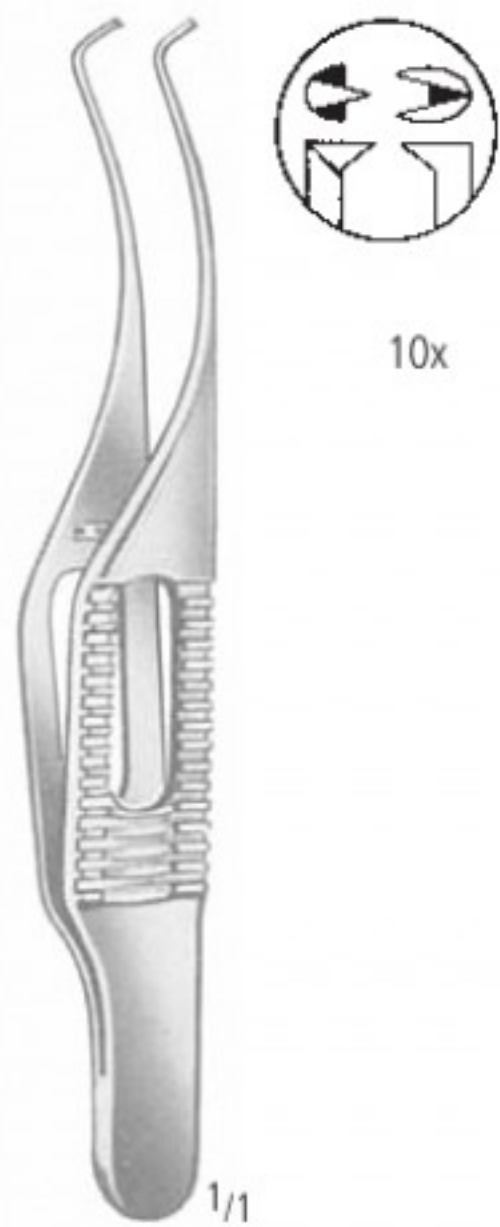

BARRAQUER-KATZIN 1:2 (Colibri)
AB 750/07
7,0 cm/2 3/4"



CASTROVIEJO 1:2
AB 816/01
0,12 mm
10,0 cm/4"



BONACCOLTO
AB 824/02
10,0 cm/4"



MOD. BONN
AB 825/02
10,0 cm/4"



FAULKNER
AB 848/11
11,0 cm/4 1/3"

ZS 160/85 VITRECTOMY - PARS PLANA- SET

mit großen Ringen
with large bows
con anillos grandes
avec grands anneaux
con anelli grandi

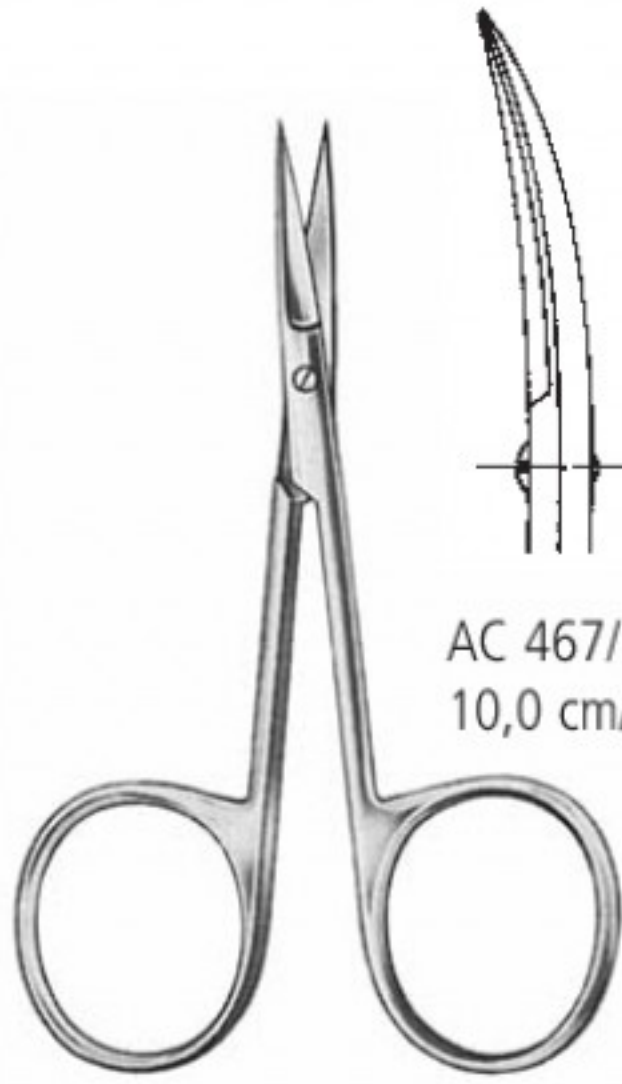

AC 467/10
10,0 cm/4"

AC 466/10
10,0 cm/4"

spitz
pointed
agudas
pointues
acuta

gerade
straight
rectas
droits
rette

gerade
straight
rectas
droits
rette

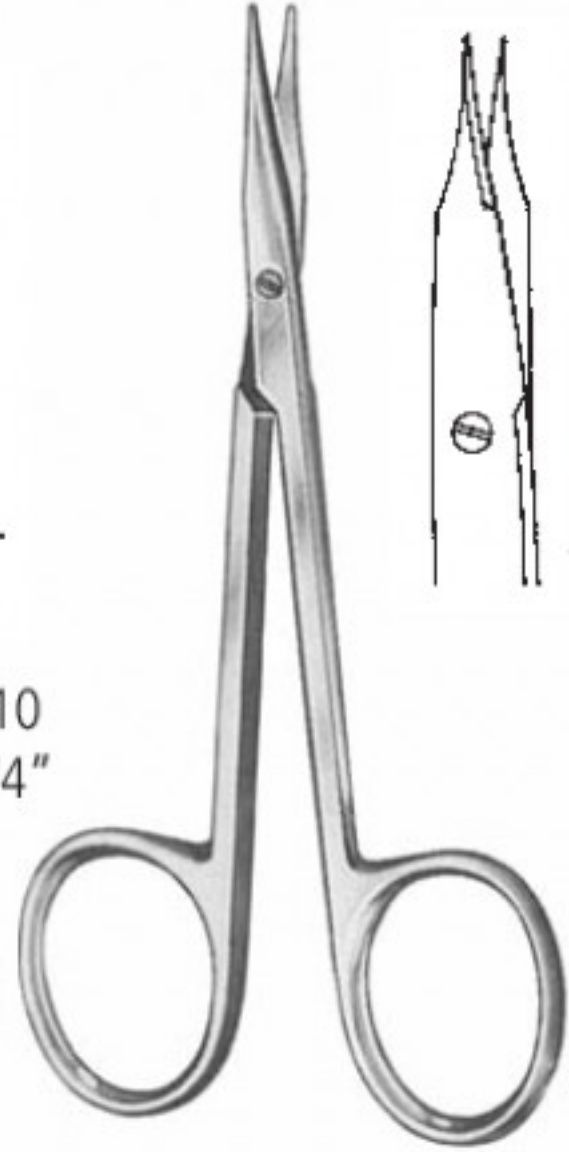

STEVENS
AC 474/11
11,5 cm/4 1/2"

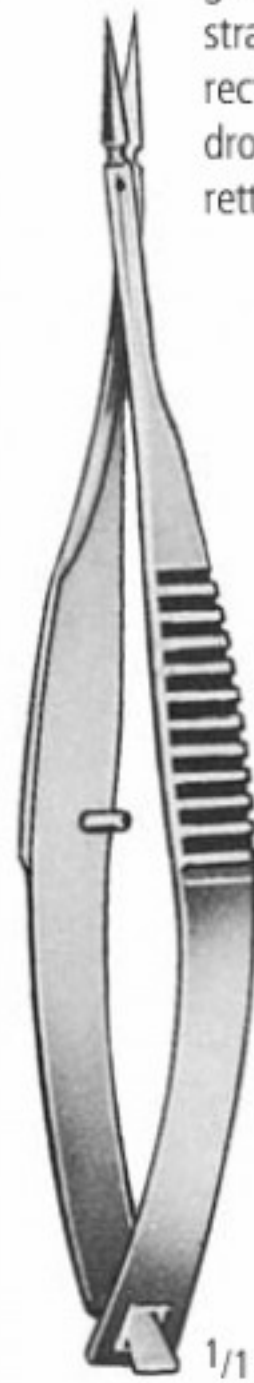

VANNAS MOD. TÜBINGEN
AC 776/01
8,5 cm/3 1/3"



WESTCOTT
AC 780/11
11,0 cm/4 1/3"



CASTROVIEJO
AE 657/14
14,0 cm/5 1/2"



CASTROVIEJO
AE 660/14
14,0 cm/5 1/2"

Messbereich 20 mm
measuring range 20 mm
campo de medición 20 mm
étendue de mesurage 20 mm
ampiezza di misura 20 mm



CASTROVIEJO
AR 282/20
8,0 cm/ 3"



JAMESON
KP 002/12
12,0 cm/4 3/4"



GASS
KP 010/14
14,0 cm/5 1/2"

B



LIEBERMAN
KP 211/08
8,0 cm/3 1/4"
B = 15 mm

ZS 160/85 VITRECTOMY -PARS PLANA- SET



SAUTTER
KP 261/15
15,0 cm/6"



ARRUGA
KP 262/13
13,0 cm/5"



KP 354/12
12,0 cm/ 4³/₄"



BISHOP-HARMON
KP 700/00

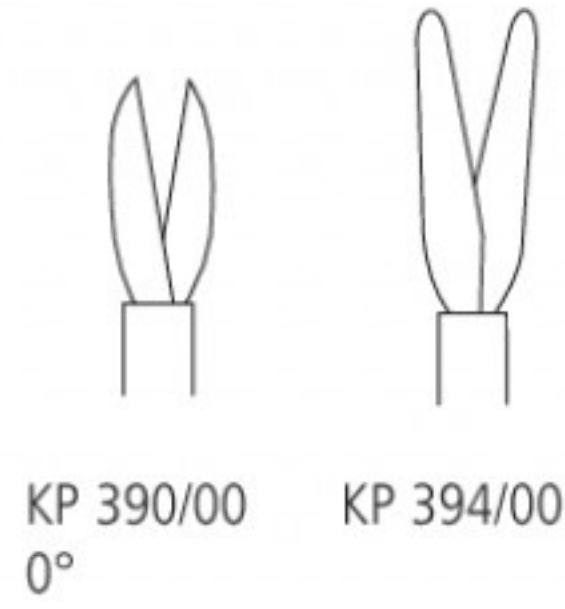

ohne Spülung
without irrigation
sin irrigaciòn
sans irrigation
senza irrigazione

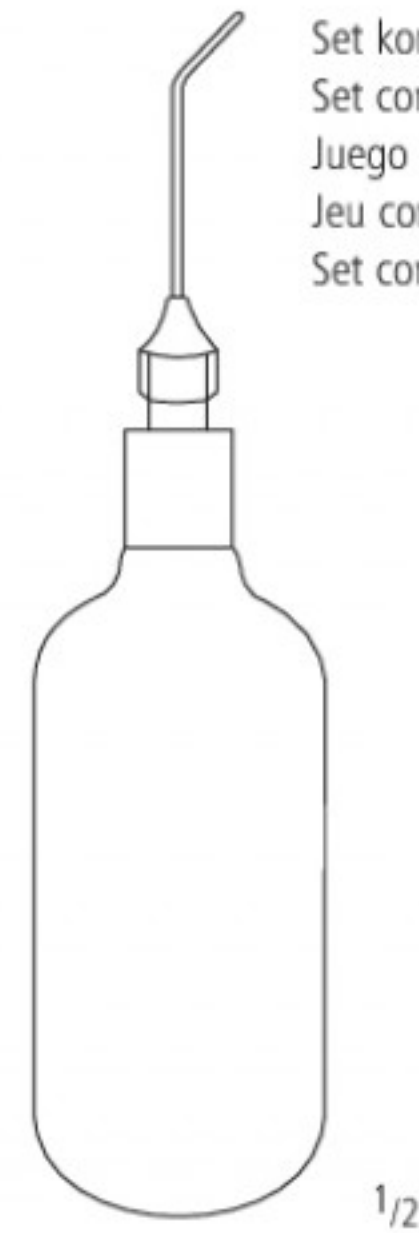

Set komplett
Set complete
Juego completo
Jeu complet
Set completo

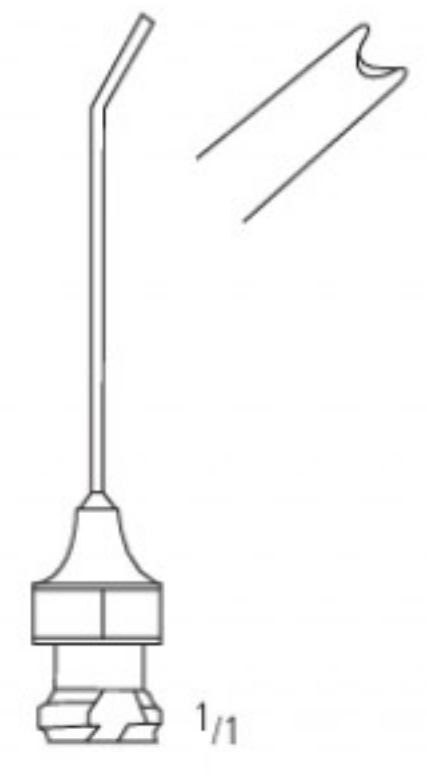

KP 760/21
4,5 cm/2"
21G

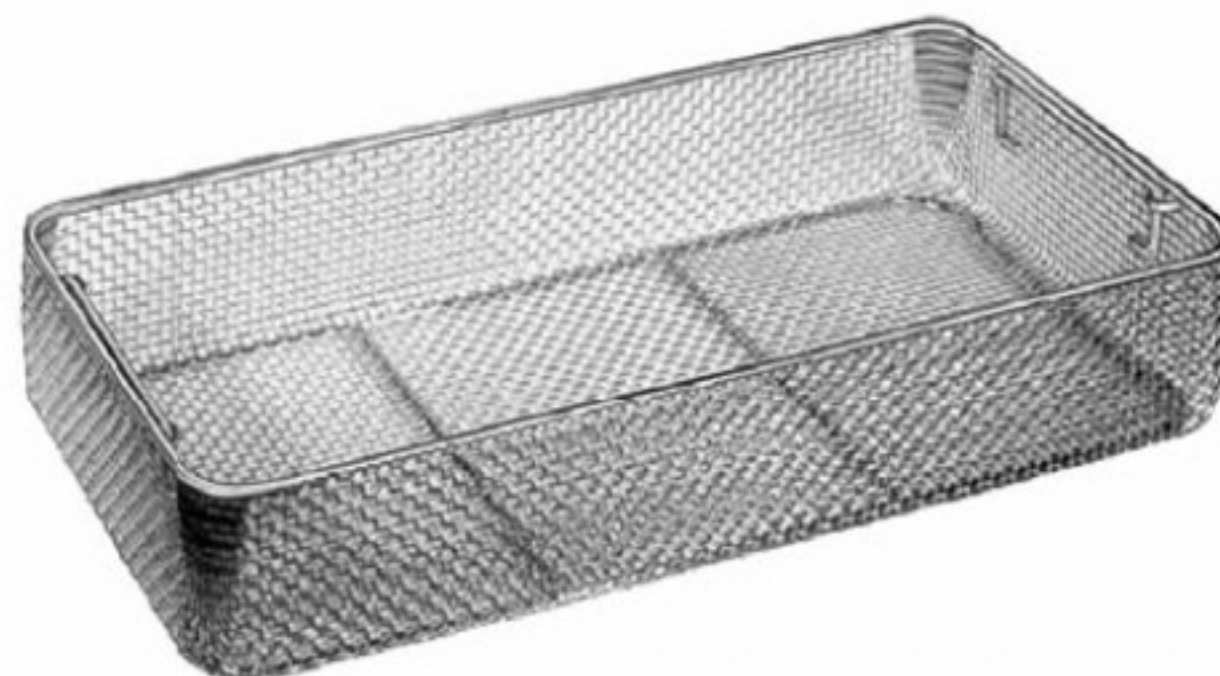

L(mm)	B(mm)	H(mm)	
485	255	50	SK 305/05

KLEMMEN
HEMOSTATS
PINZAS HEMOSTATICAS
PINCES HEMOSTATIQUES
PINZE EMOSTATICHE

AA

nopa[®] instruments



KLEMMEN HEMOSTATS PINZAS HEMOSTATICAS PINCES HEMOSTATIQUES PINZE EMOSTATICHE

Bulldogklemmen, Anlegezangen
 Bulldog Clamps, Setting Forceps
 Clamps Bulldog, Pinza para poner
 Clamps Bulldog, Pince à poser
 Pinze Bulldog, Pinza per posizionare

AA

AB

AC

AD

AE

AK

AR

KA

KM

KO

KP

KYE

XR



1/1

DIEFFENBACH



1/1

AA 060/03
3,5 cm/1 1/2"



1/1

AA 060/05
5,0 cm/2"

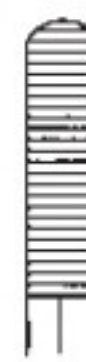

1/1

AA 060/06
6,0 cm/2 1/2"



1/1

AA 061/03
3,5 cm/1 1/2"



1/1

AA 061/05
5,0 cm/2"



1/1

AA 061/06
6,0 cm/2 1/2"



1/2

JOHNS-HOPKINS

AA 069/24
24,5 cm/9 3/4"



1/1

JOHNS-HOPKINS



1/1

AA 070/04
4,0 cm/1 1/2"



1/1

AA 070/05
5,0 cm/2"



1/1

AA 070/06
6,5 cm/2 1/2"



1/1

AA 070/07
7,5 cm/3"



1/1

AA 070/09
9,0 cm/3 1/2"



1/1

AA 071/04
4,0 cm/1 1/2"



1/1

AA 071/05
5,0 cm/2"

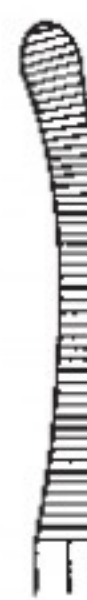

1/1

AA 071/06
6,5 cm/2 1/2"



1/1

AA 071/07
7,5 cm/3"



1/1

AA 071/09
9,0 cm/3 1/2"

Arterienklemmen
 Artery Forceps
 Pinzas hemostáticas
 Pincas hémostatiques
 Pinze emostatiche

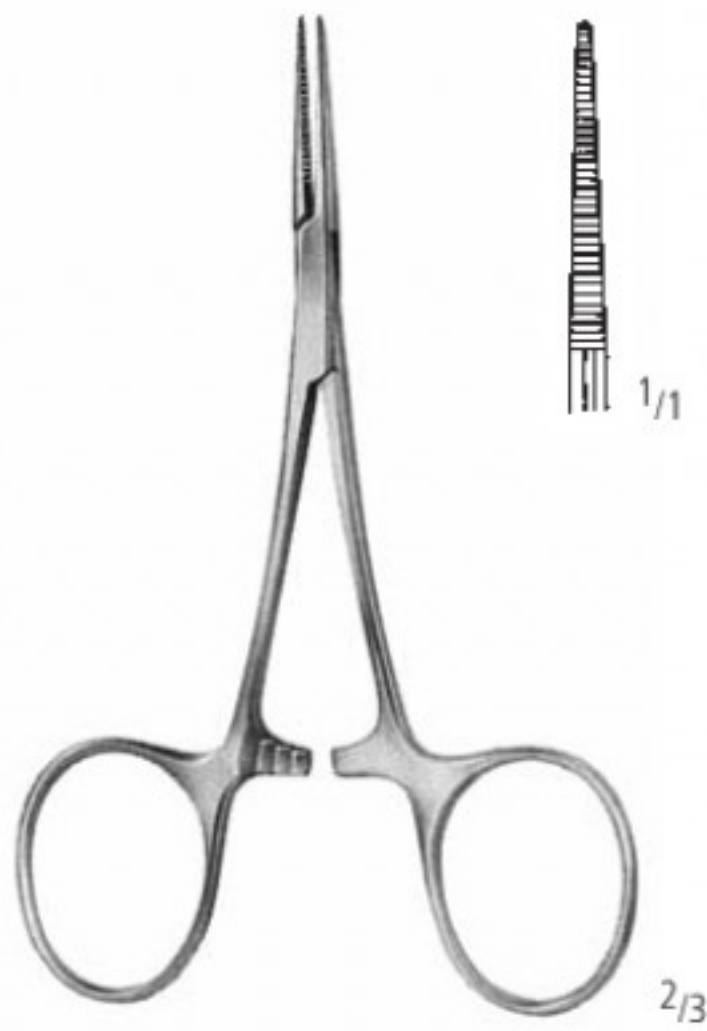

HARTMANN
 AA 114/10
 10,0 cm/4"

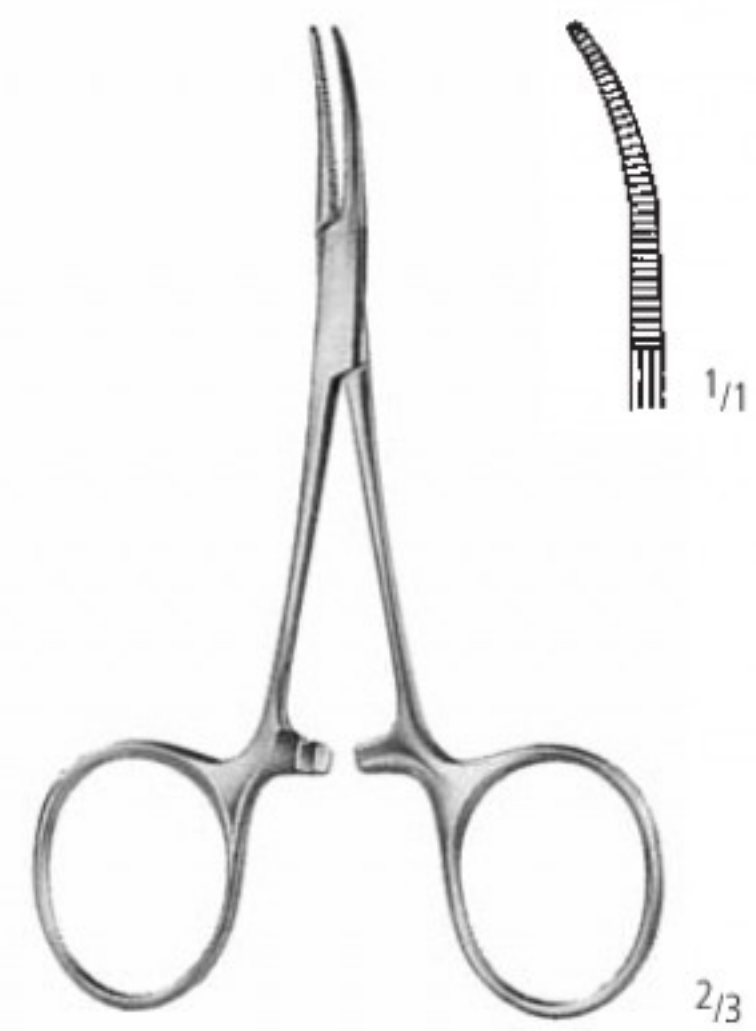

HARTMANN
 AA 115/10
 10,0 cm/4"

WILLIAM STEWART HALSTED
 was professor of surgery in the
 Johns Hopkins University.
 In 1890 he had bronze casts made
 of his own hands. On these casts
 the first surgical rubber gloves
 were moulded.

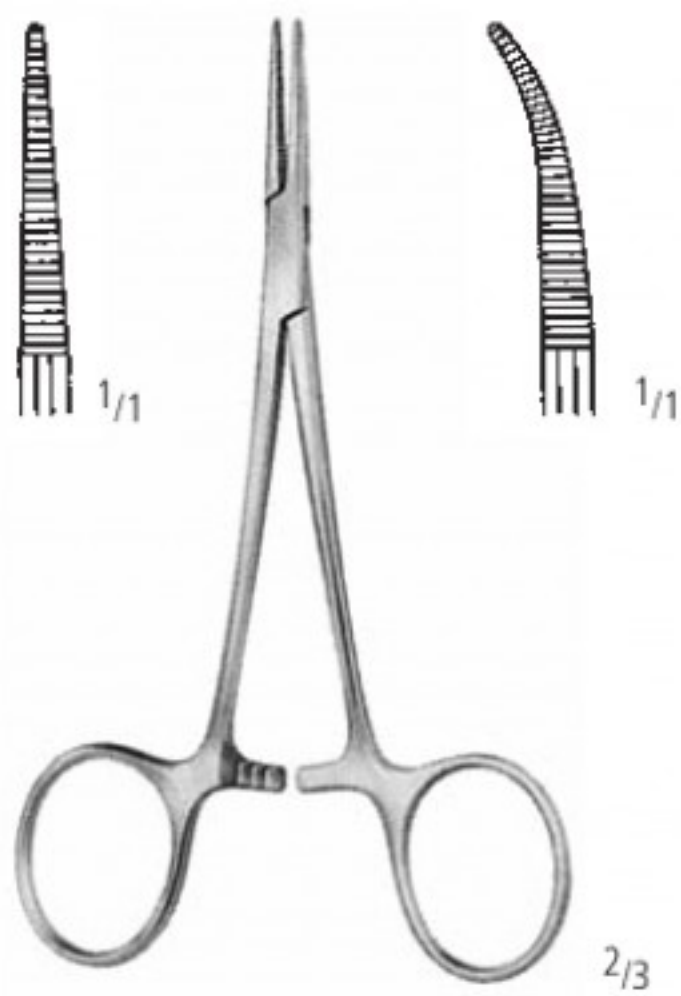

HALSTED-MOSQUITO
 AA 150/12 AA 151/12 12,5 cm/5"
 AA 150/14 AA 151/14 14,0 cm//5 1/2"

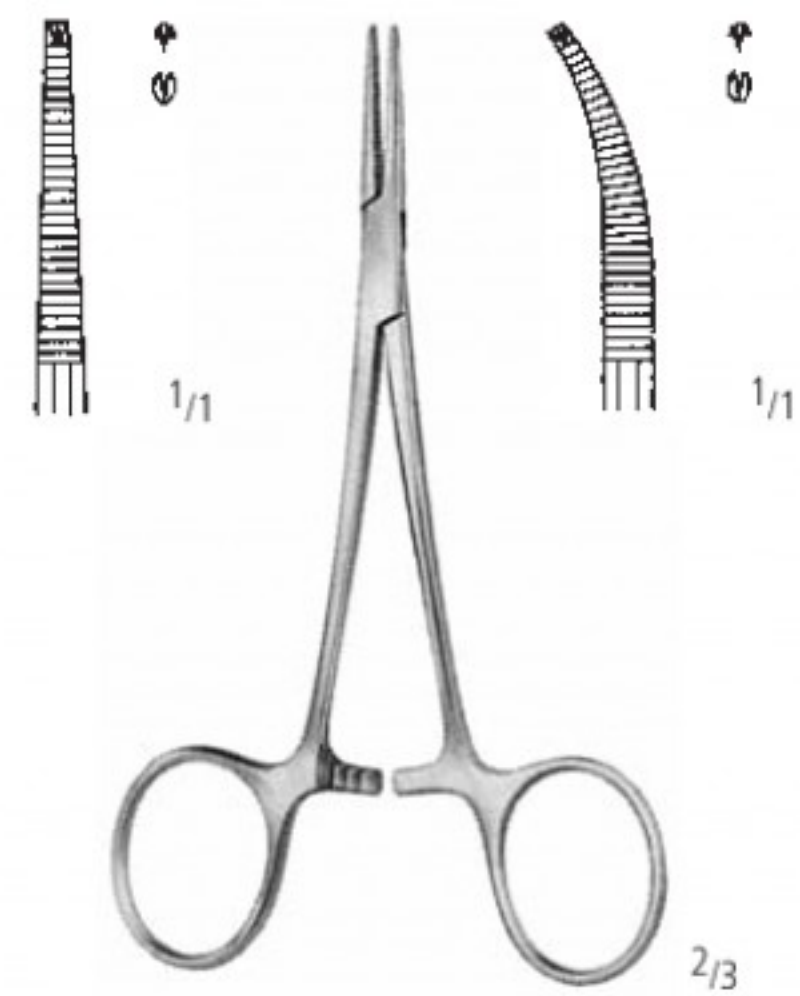

HALSTED-MOSQUITO 1:2
 AA 152/12 AA 153/12
 AA 152/14 AA 153/14

Tuchklemmen
Towel Forceps
Pinzas para compresas, Pinzas de campo
Pinces à champs, Pinces à compresses
Pinze per fissare le compresse (Fissarele)

AA

AB

AC

AD

AE

AK

AR

KA

KM

KO

KP

KYE

XR

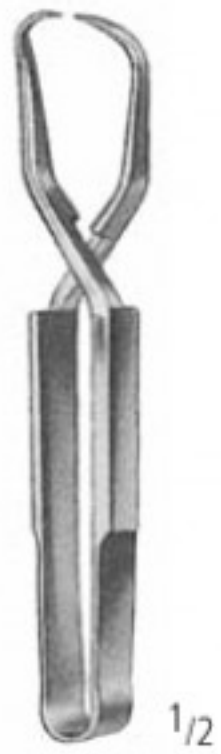

SCHAEDEL
AA 710/09
9,0 cm/3 1/2"



JONES
5,0 cm/2"
9,0 cm/3 1/2"
AA 711/05
AA 711/09



AA 749/11
11,0 cm/4 1/2"

mit Schlauch- oder Kabelhalter
with clip for tubing or cable
con porta-tubo o porta-cable
avec clamp porte-tube ou porte-
-corton d'alimentation
con porta tubo o porta cavo

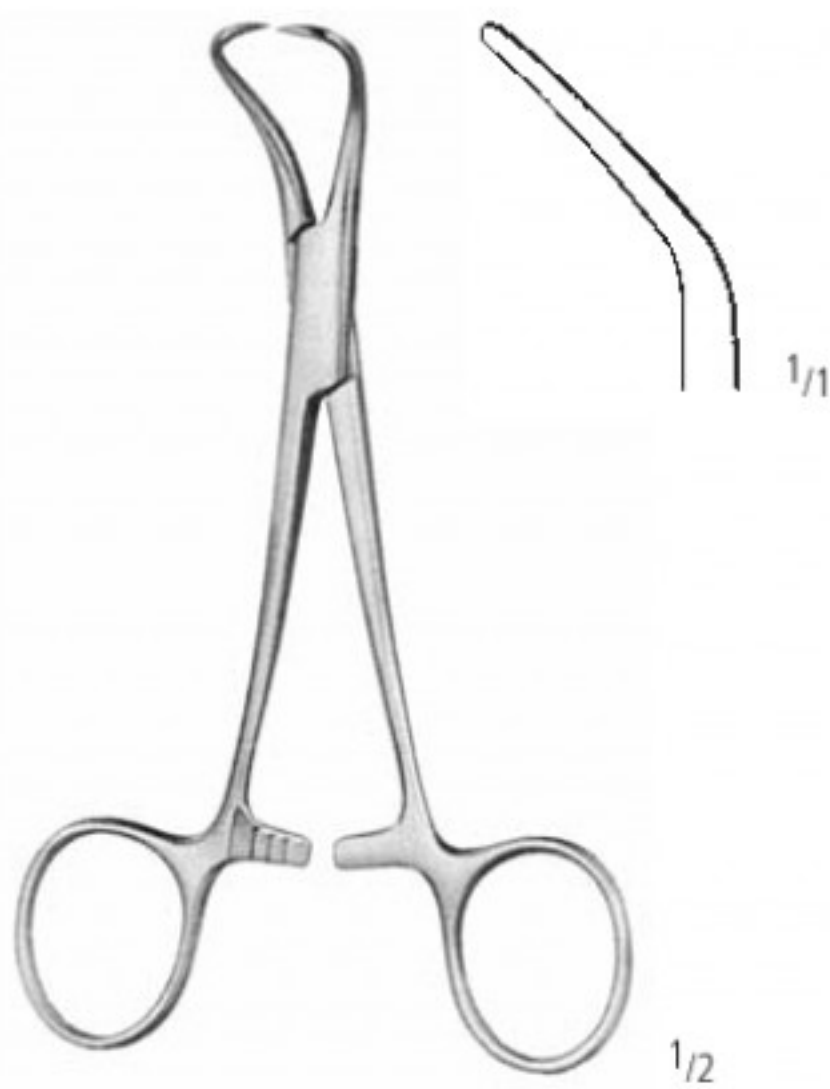

BACKHAUS
8,0 cm/3 1/4" AA 751/08
11,0 cm/4 1/2" AA 751/11
13,0 cm/5" AA 751/13
15,0 cm/6" AA 751/15



ROEDER
13,0 cm/5" AA 761/13
15,0 cm/6" AA 761/15

Tuchklemmen
Towel Forceps
Pinzas para compresas, Pinzas de campo
Pinces à champs, Pinces à compresses
Pinze per fissare le compresse (Fissarele)

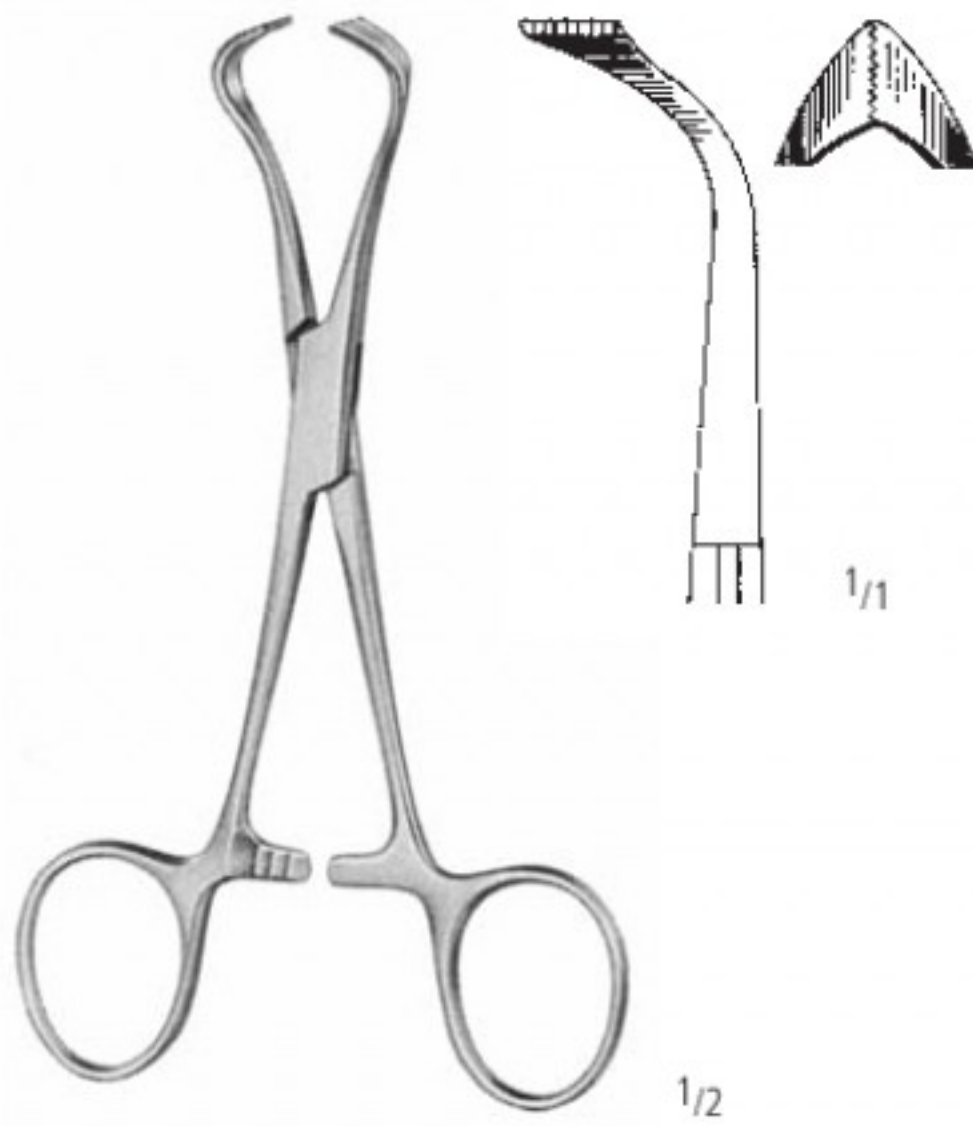

LORNA

10,0 cm/4" AA 763/10
13,0 cm/5" AA 763/13

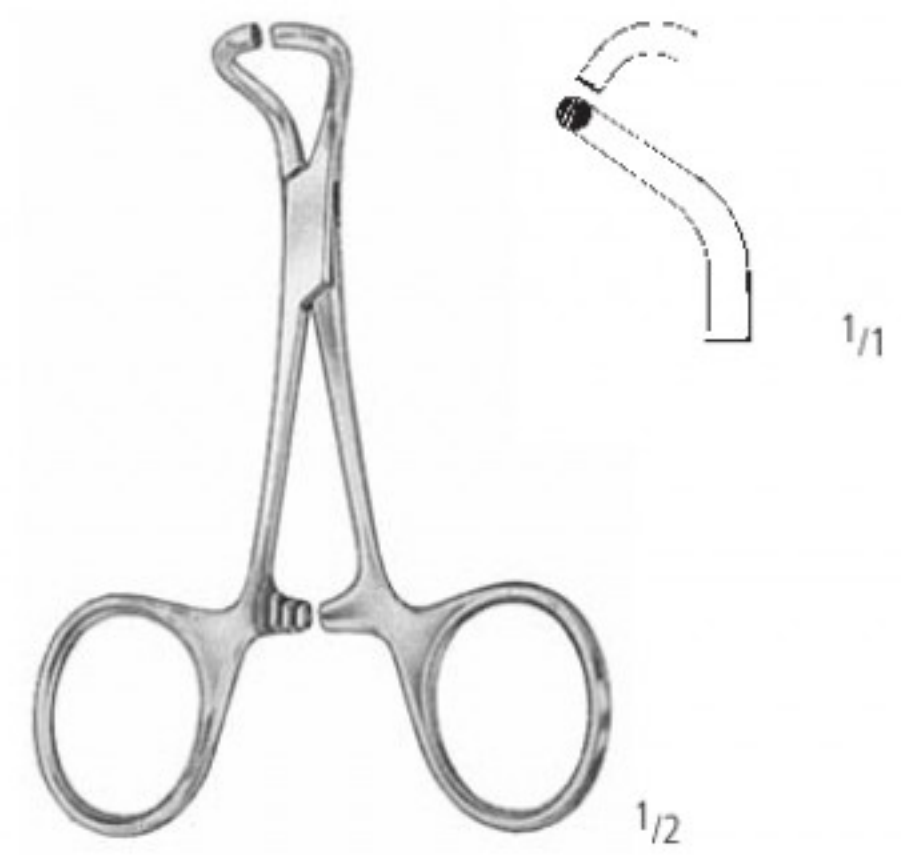

TOHOKU-JAPAN

10,0 cm/4" AA 764/10
13,0 cm/5" AA 764/13

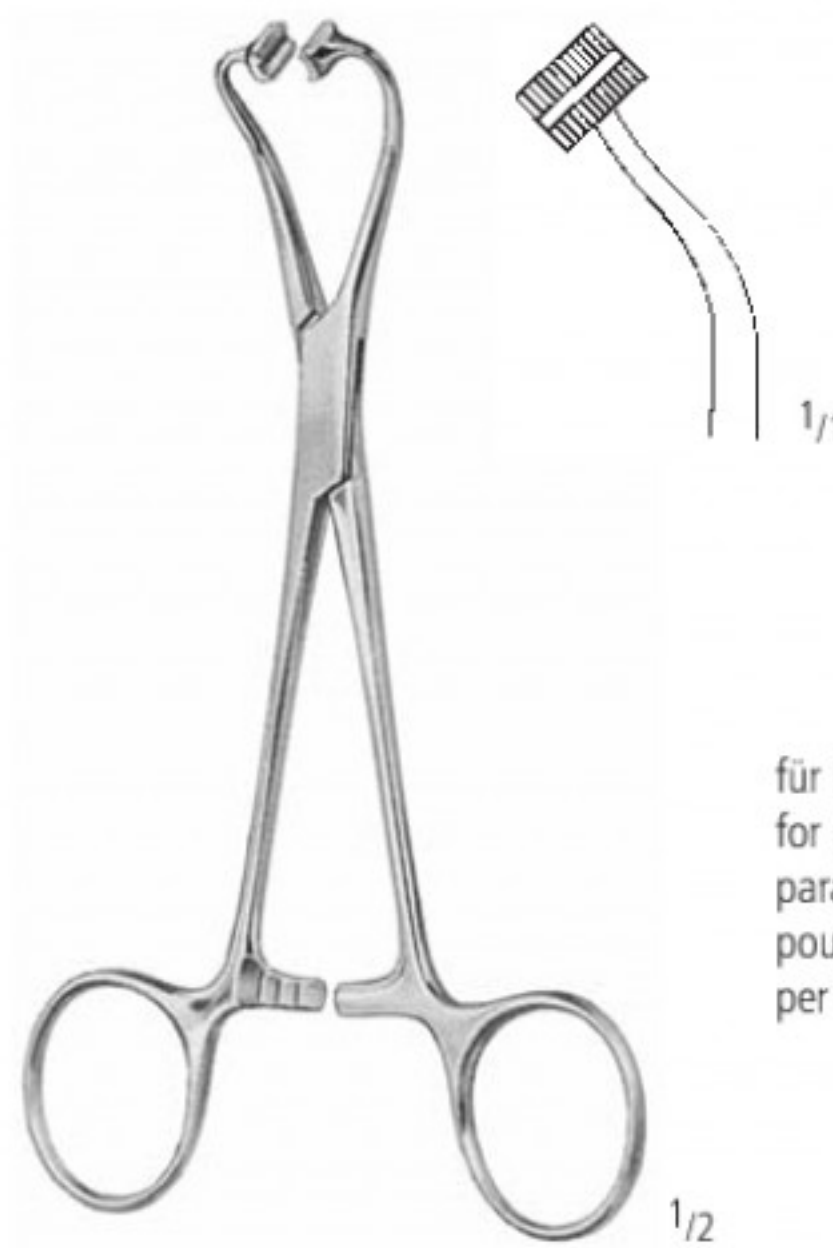

PEERS

AA 765/14
14,5 cm/5³/₄"

für Papiertücher
for paper tissues
para servilletas de papel
pour serviettes en papier
per tessuti di carta

PINZETTEN
FORCEPS
PINZAS
PINCES
PINZE

AB

nopa[®] instruments



AB PINZETTEN FORCEPS PINZAS PINCES PINZE

Anatomische Pinzetten, Chirurgische Pinzetten
 Dressing Forceps, Tissue Forceps
 Pinzas de disección, Pinzas de disección con dientes
 Pincés à dissection, Pincés a griffes
 Pinze anatomiche per dissezione, Pinze chirurgiche a denti di topo

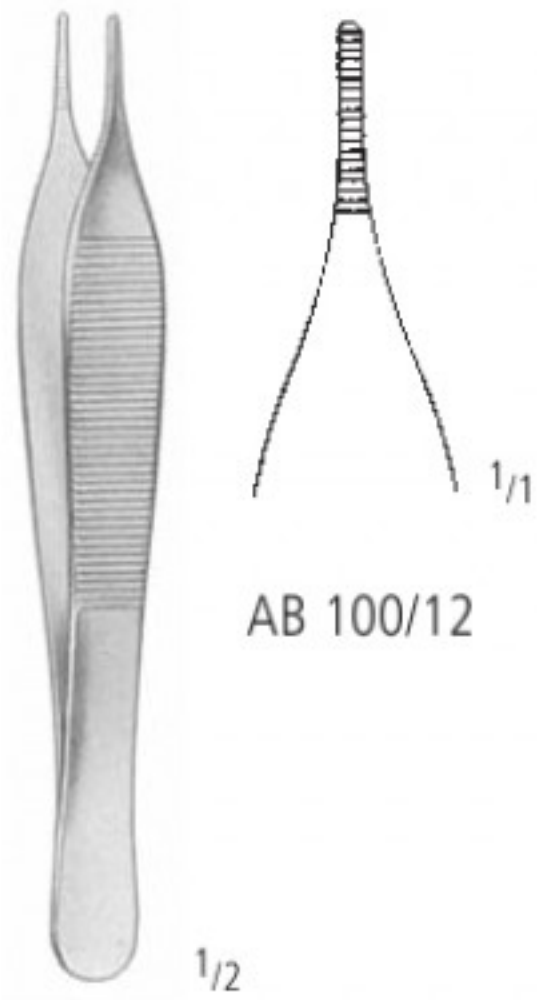

AB 100/12



AB 102/12

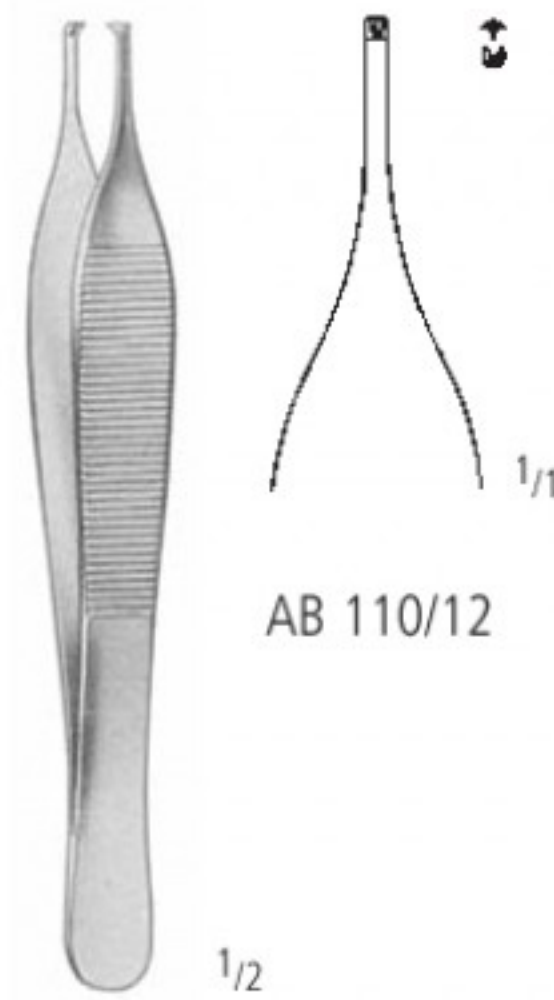

AB 110/12

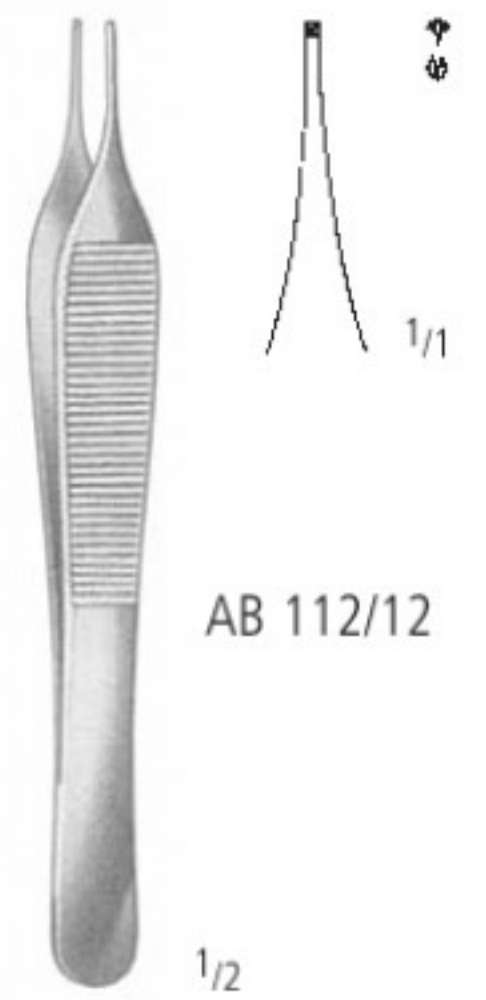

AB 112/12

12,0 cm/4³/₄"
 15,0 cm/6"

ADSON
 AB 100/12
 AB 100/15

MICRO-ADSON
 AB 102/12
 AB 102/15

ADSON 1:2
 AB 110/12
 AB 110/15

MICRO-ADSON 1:2
 AB 112/12
 AB 112/15

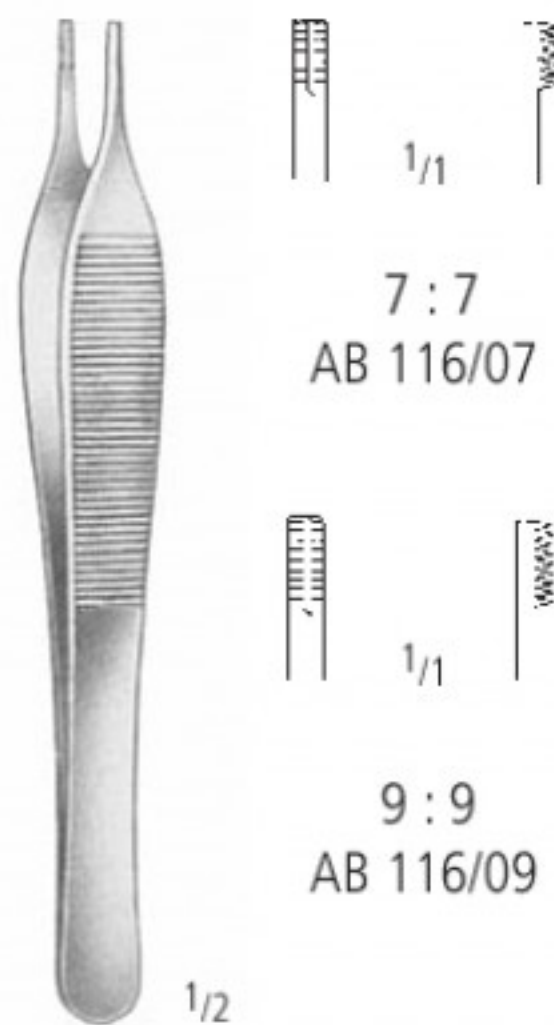

7 : 7
 AB 116/07

9 : 9
 AB 116/09

ADSON-BROWN

12,0 cm/4³/₄"

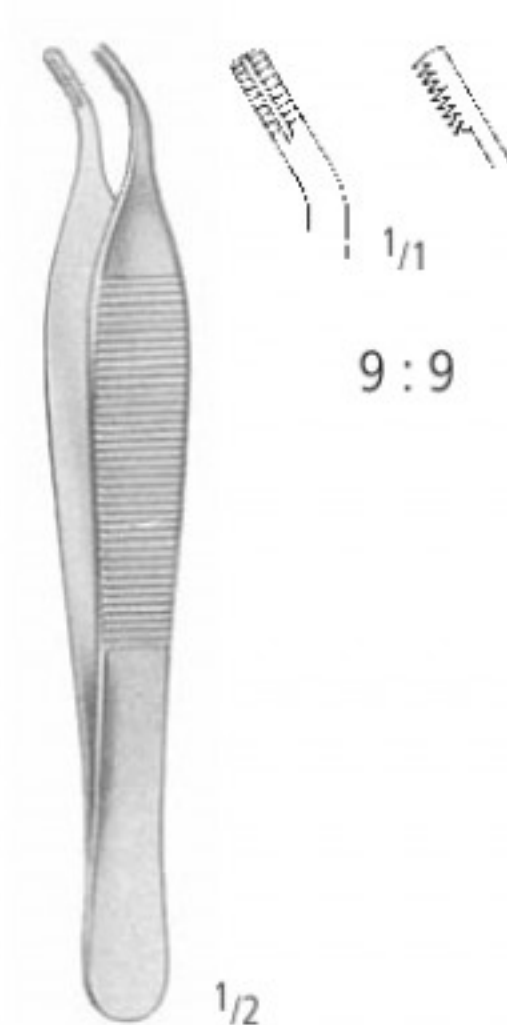

9 : 9

ADSON-BROWN

AB 117/09
 12,0 cm/4³/₄"

PINZETTEN FORCEPS PINZAS PINCES PINZE

Cilienpinzetten
Cilia Forceps
Pinzas de depilatorias
Pincas à épiler les cils
Pinze depilatorie



LITTAUER
AB 620/08
8,5 cm/3 1/2"



AB 621/09
9,0 cm/3 1/2"



DOUGLAS
AB 624/09
9,0 cm/3 1/2"

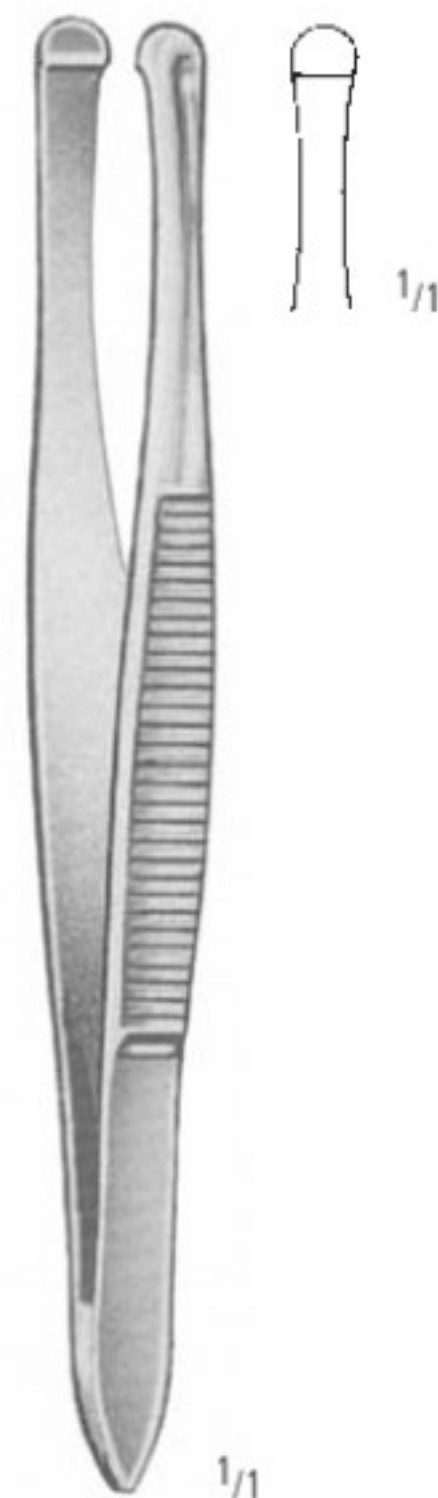

BEER
AB 626/09
9,0 cm/3 1/2"



ZIEGLER
AB 628/09
9,0 cm/3 1/2"



BARRAQUER
AB 633/10
10,5 cm/4 1/4"



GRADLE
AB 635/09
9,5 cm/3 3/4"

AA

AB

AC

AD

AE

AK

AR

KA

KM

KO

KP

KYE

XR

AB PINZETTEN FORCEPS PINZAS PINCES PINZE

Irispinzetten
Iris Forceps
Pinzas para iris
Pinces à iris
Pinze per iride



AB 700/07

GRAEFE
7,0 cm/2³/₄"



AB 701/07

GRAEFE
7,0 cm/2³/₄"



AB 702/07

GRAEFE 1:2
7,0 cm/2³/₄"

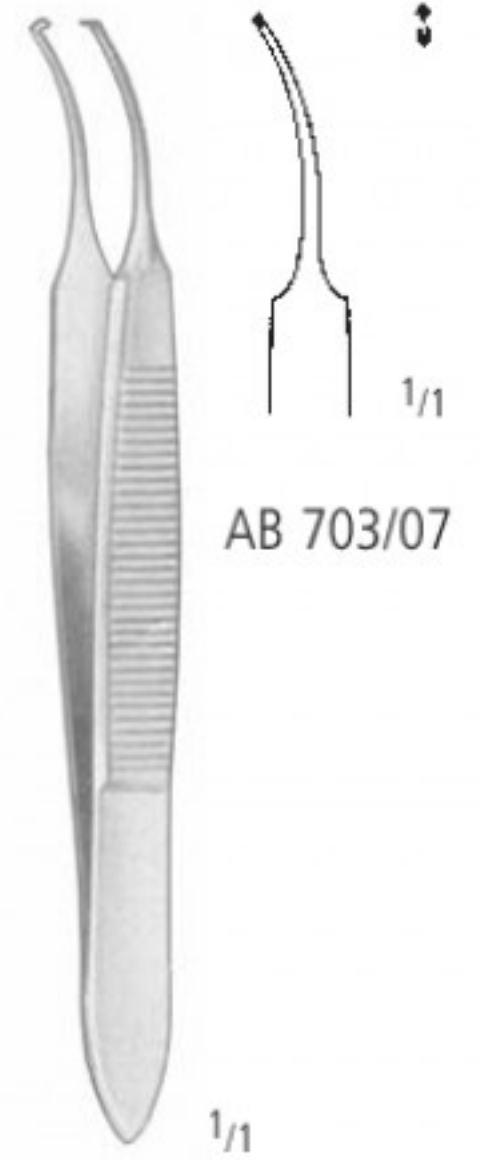

AB 703/07

GRAEFE 1:2
7,0 cm/2³/₄"

0,5 mm AB 700/05
0,7 mm AB 700/07
1,0 mm AB 700/10

AB 701/05
AB 701/07
AB 701/10

AB 702/05
AB 702/07
AB 702/10

AB 703/05
AB 703/07
AB 703/10



7,0 cm/2³/₄" AB 710/07
10,0 cm/4" AB 710/10



AB 711/07
AB 711/10



AB 713/07
AB 713/10



AB 714/07
AB 714/10



AB 715/07
AB 715/10



AB 717/07
AB 717/10

GRAEFE

PINZETTEN FORCEPS PINZAS PINCES PINZE

Irispinzetten
Iris Forceps
Pinzas para iris
Pincès à iris
Pinze per iride

AA

AB

AC

AD

AE

AK

AR

KA

KM

KO

KP

KYE

XR



STEVENS 1:2
AB 718/01
11,0 cm/4¹/₂"

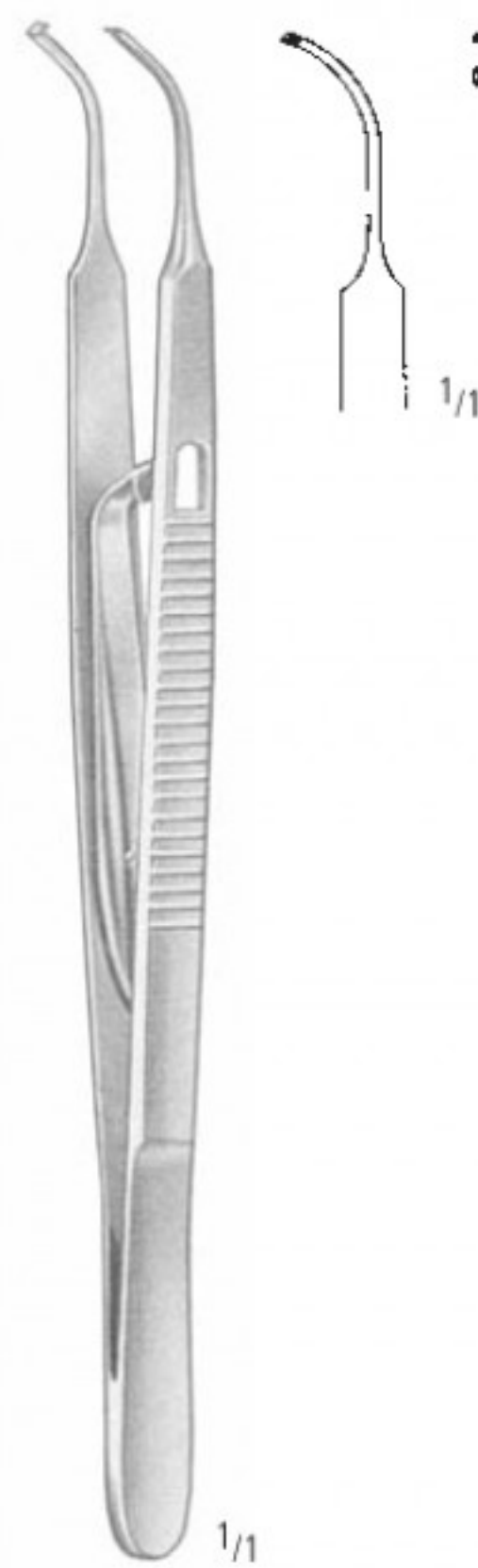

STEVENS 1:2
AB 718/02
11,0 cm/4¹/₂"

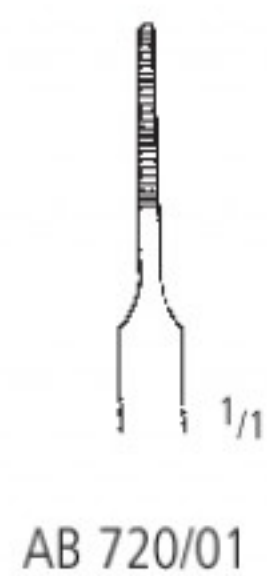

AB 720/01



AB 720/02



AB 720/03



AB 721/01 1:2



AB 721/02 1:2

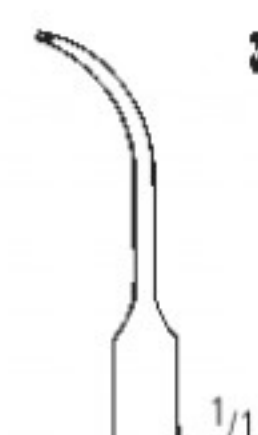

AB 721/03 1:2

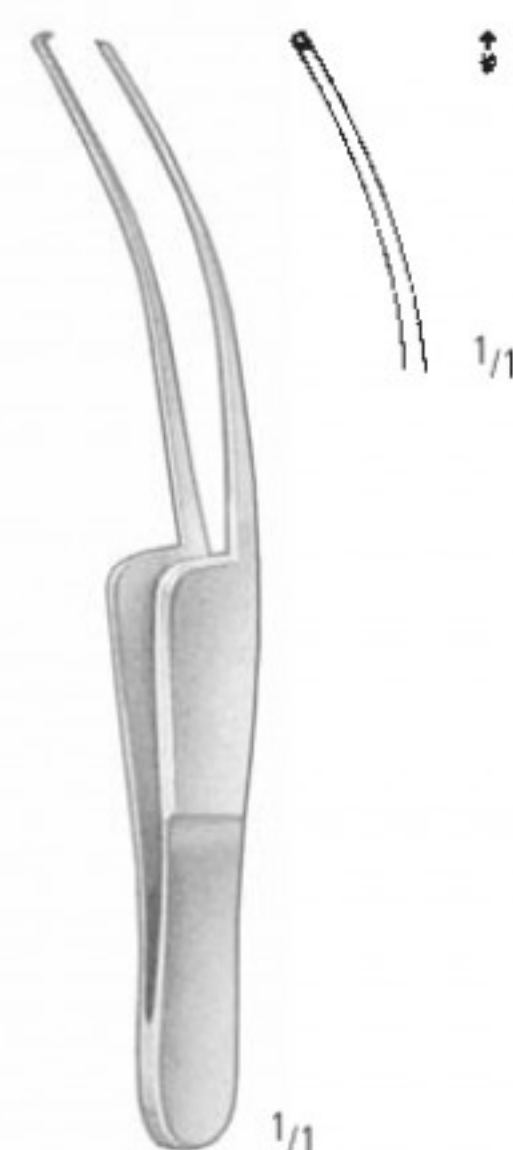

FISCHER-ARLT 1:2
AB 723/07
7,0 cm/2³/₄"

STEVENS
10,5 cm/4¹/₂"

AB PINZETTEN FORCEPS PINZAS PINCES PINZE

Irispinzetten
Iris Forceps
Pinzas para iris
Pincès à iris
Pinze per iride



FOERSTER
AB 726/08
8,5 cm/3 1/2"



FOERSTER
AB 727/08
8,5 cm/3 1/2"



FOERSTER 1:2
AB 728/08
8,5 cm/3 1/2"



FOERSTER 1:2
AB 729/08
8,5 cm/3 1/2"



HESS 1:2
AB 730/07
7,0 cm/2 3/4"



HESS 1:2
AB 731/09
9,0 cm/3 1/2"



MOD. BONN 1:2
AB 734/01
7,0 cm/2 3/4"

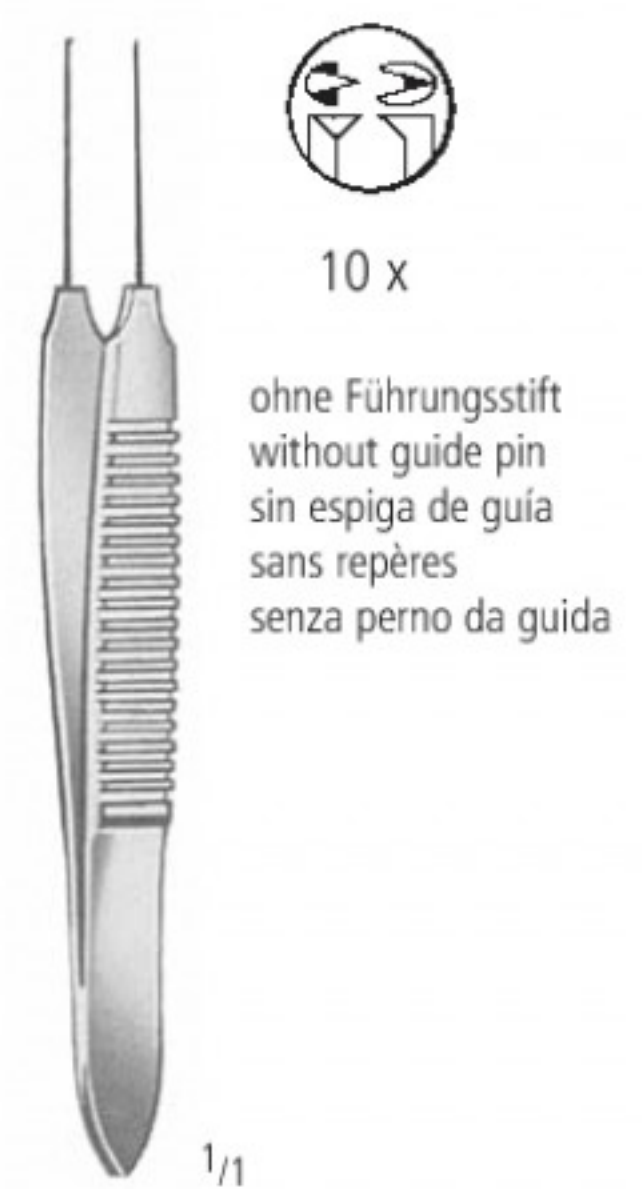

MOD. BONN 1:2
AB 734/02
7,0 cm/2 3/4"

PINZETTEN FORCEPS PINZAS PINCES PINZE

Irispinzetten
Iris Forceps
Pinzas para iris
Pinces à iris
Pinze per iride

AA

AB

AC

AD

AE

AK

AR

KA

KM

KO

KP

KYE

XR



MOD. BONN
7,0 cm/2³/₄"

AB 735/01

AB 735/02



AB 736/08

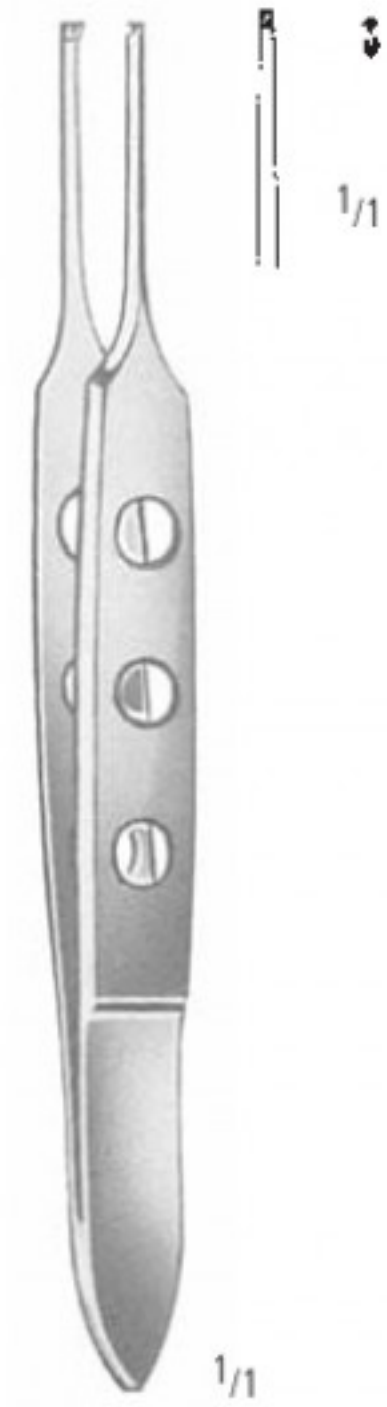

AB 738/08



AB 740/08



AB 742/08

BISHOP-HARMON
8,5 cm/3¹/₂"



KIRBY 1:2
AB 748/09
9,0 cm/3¹/₂"

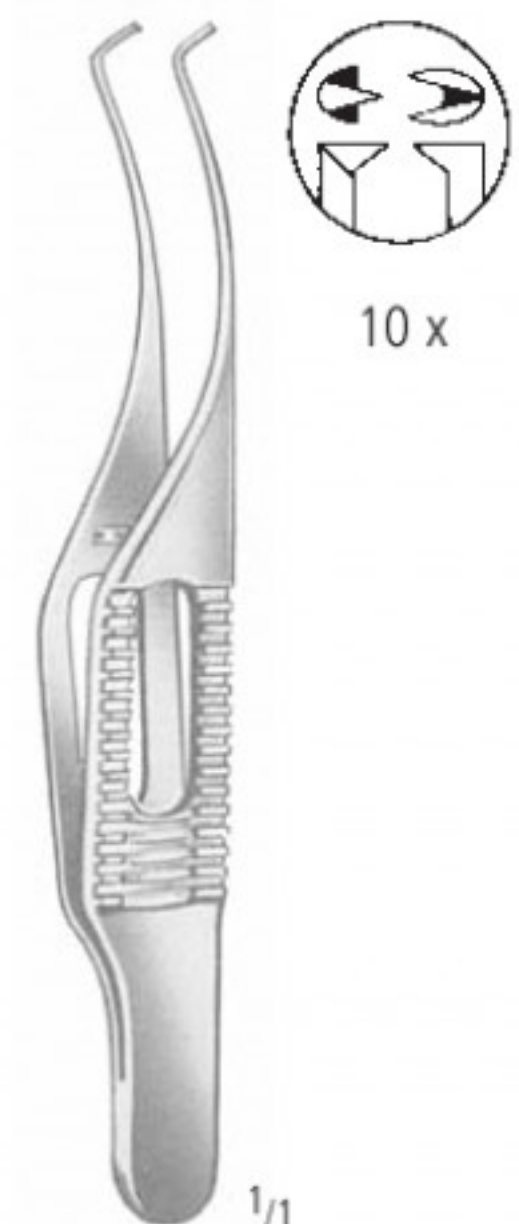

BARRAQUER-KATZIN 1:2
(Colibri)
AB 750/07
7,0 cm/2³/₄"

AB PINZETTEN FORCEPS PINZAS PINCES PINZE

Irispinzetten, Kapselpinzetten
 Iris Forceps ,Capsular Forceps
 Pinzas para iris, Pinzas capsulares
 Pincés à iris, Pincés capsulaires
 Pinze per iride, Pinze capsulari

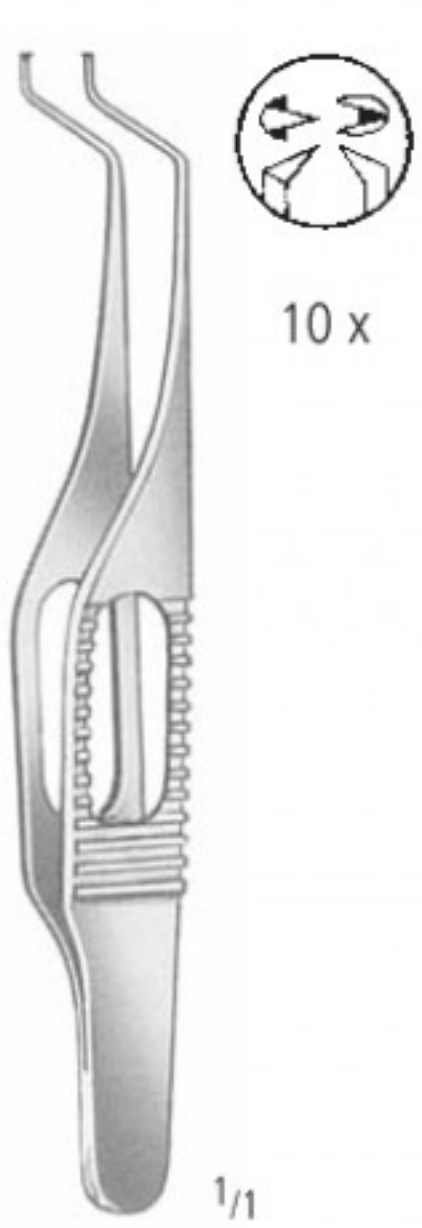

TROUTMAN 1:2
(Corneal)
 AB 751/07
 7,5 cm/3"



BARRAQUER-KATZIN 1:2
(Colibri)
 AB 752/07
 7,0 cm/2³/₄"

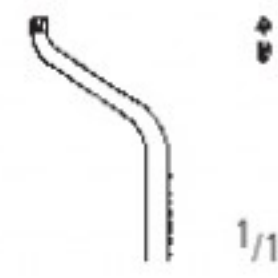

AB 756/07
 Zähne seitwärts
 teeth on side
 dientes laterales
 dents latérales
 denti laterali

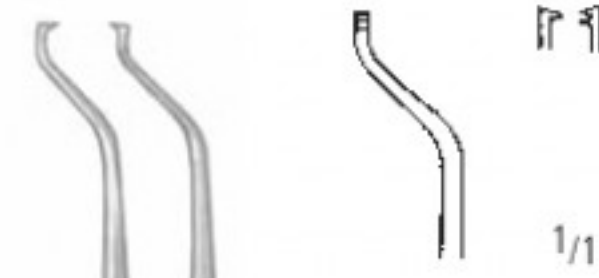

AB 757/07
 Zähne unten
 teeth below
 dientes inferiores
 dents en bas
 denti in basso



GILL-HESS 1:2
 7,5 cm/3"



GILL 1:2
 AB 762/07
 7,5 cm/3"

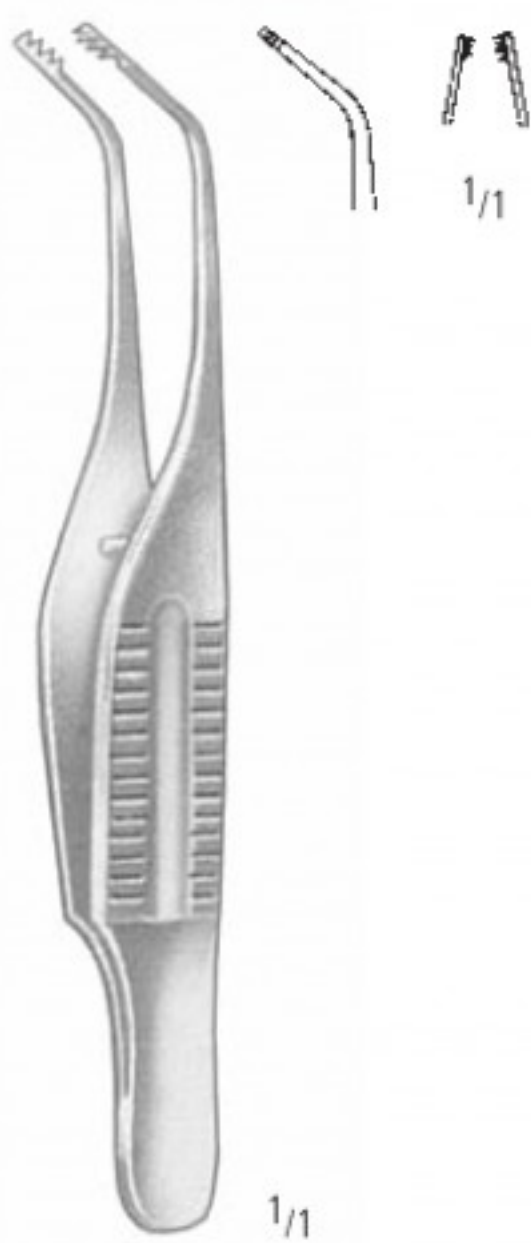

GILL-FUCHS
 AB 763/07
 7,5 cm/3"

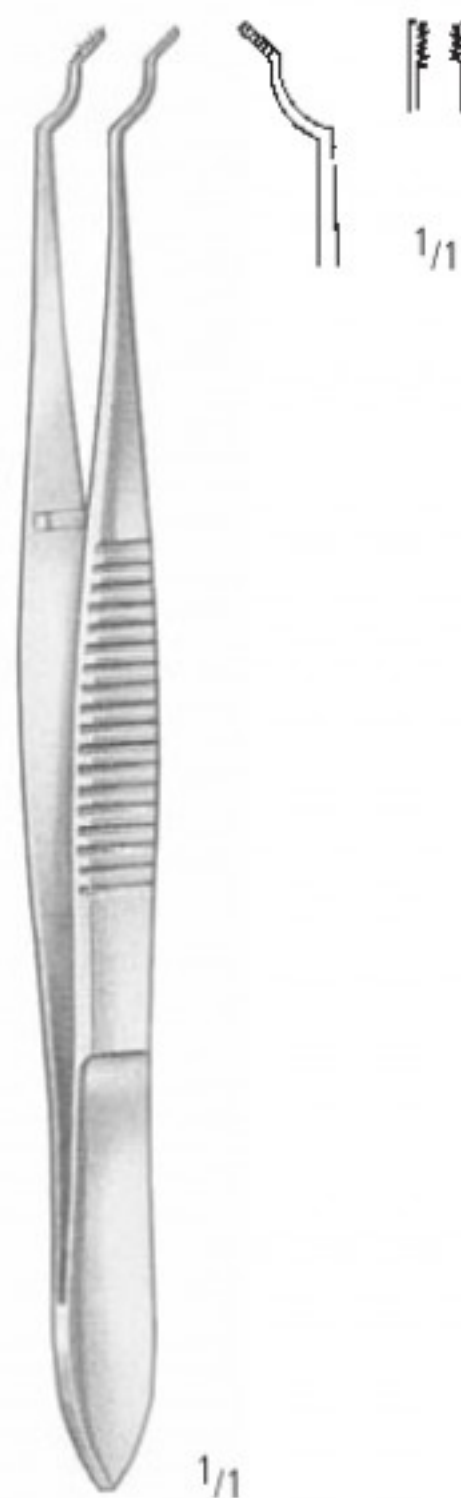

TERSON
 AB 765/09
 9,0 cm/3¹/₂"



CASTROVIEJO
 AB 767/01
 10,0 cm/4"



CASTROVIEJO
 AB 767/02
 10,0 cm/4"

PINZETTEN FORCEPS PINZAS PINCES PINZE

Kapselpinzetten, Fixierpinzetten
 Capsular Forceps, Fixation Forceps
 Pinzas capsulares, Pinzas de fijación
 Pincas capsulaires, Pincas à fixer
 Pinze capsulari, Pinze fissatrici

AA

AB

AC

AD

AE

AK

AR

KA

KM

KO

KP

KYE

XR

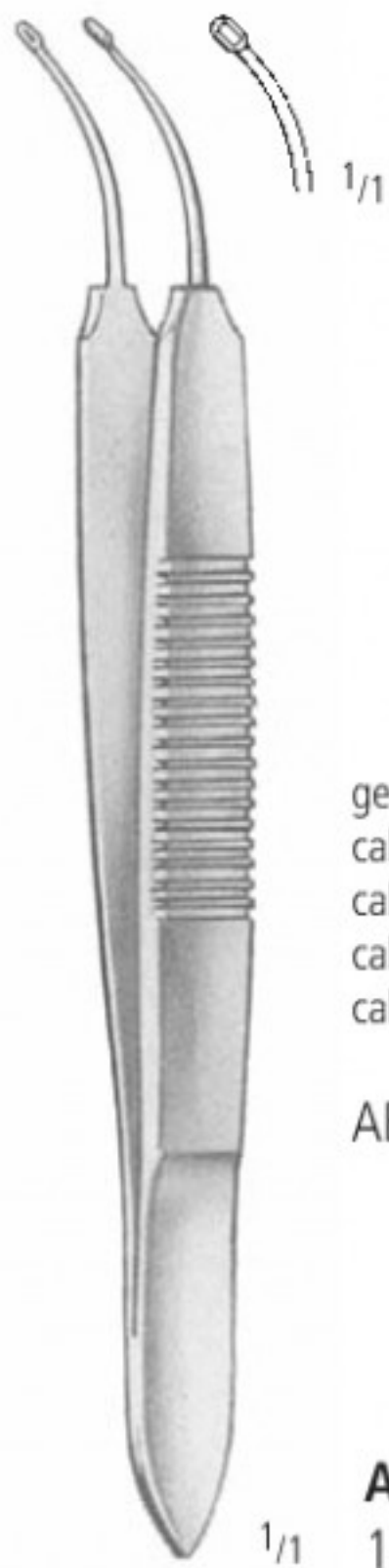

ungeeicht
 not calibrated
 no calibrada
 non calibrée
 non calibrata

AB 768/01

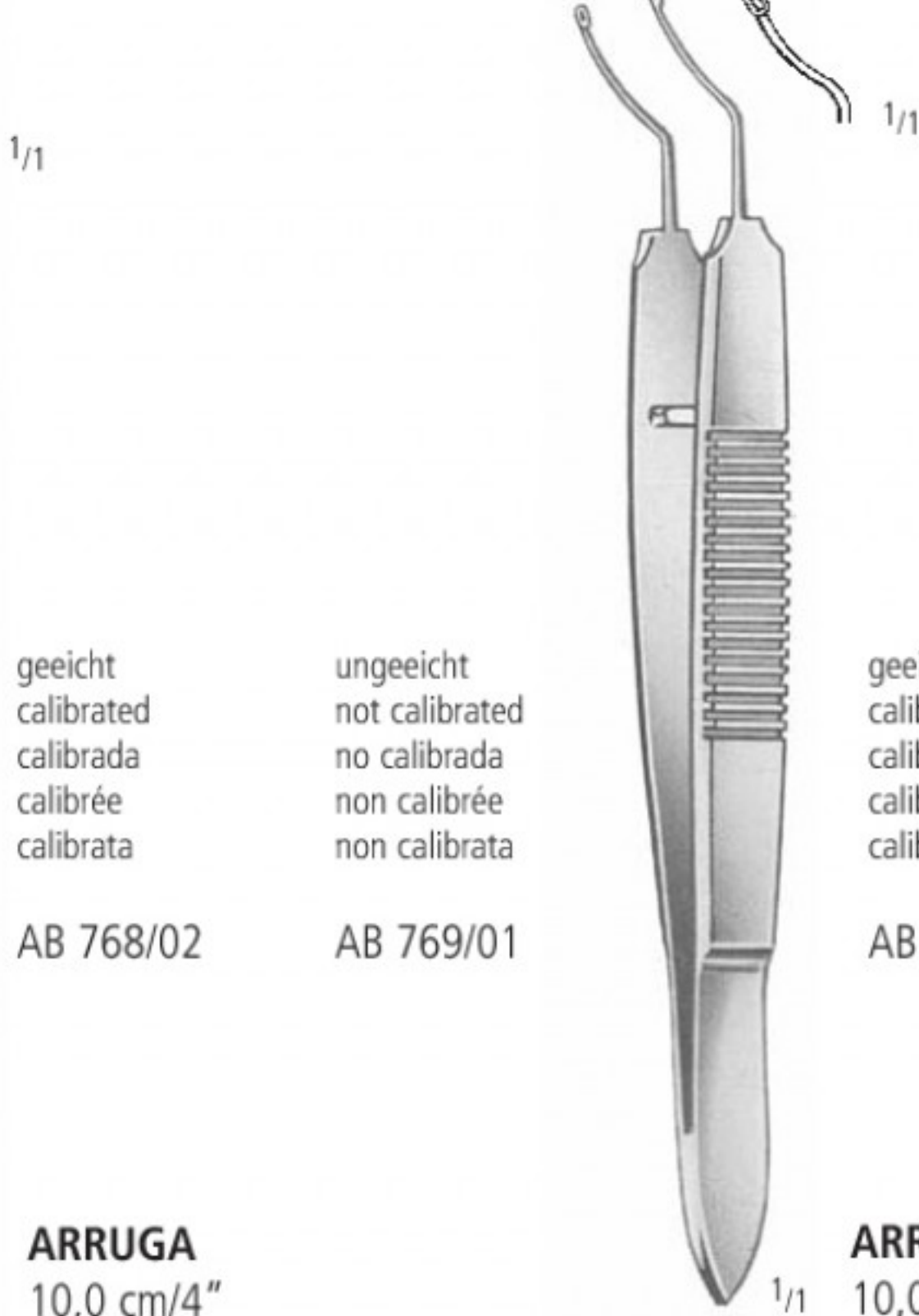

geeicht
 calibrated
 calibrada
 calibrée
 calibrata

AB 768/02

ungeeicht
 not calibrated
 no calibrada
 non calibrée
 non calibrata

AB 769/01



geeicht
 calibrated
 calibrada
 calibrée
 calibrata

AB 769/02

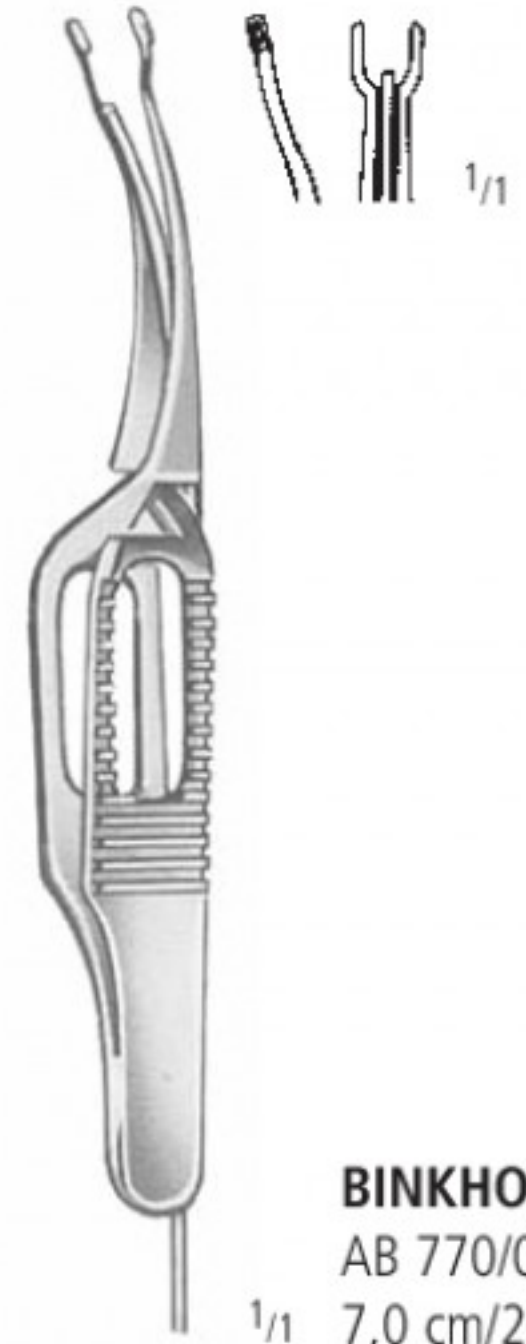

BINKHORST
 AB 770/07
 7,0 cm/2³/₄"



AB 785/01

ohne Schloss
 without spring catch
 sin cierre de resorte
 sans arrêt à ressort
 senza arresto a molla

AB 785/02

mit Schloss
 with spring catch
 con cierre de resorte
 avec arrêt à ressort
 con arresto a molla

GRAEFE
 11,0 cm/4¹/₂"



AB 786/01
 5 mm



AB 786/02
 10 mm



GREEN
 10,0 cm/4"

AB PINZETTEN FORCEPS PINZAS PINCES PINZE

Fixierpinzetten, Nahtpinzetten
 Fixation Forceps, Suture Forceps
 Pinzas de fijación, Pinzas para sutura
 Pincès à fixer, Pincès pour sutures
 Pinze fissatrici, Pinze per sutura

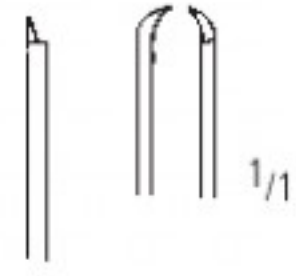

AB 790/09

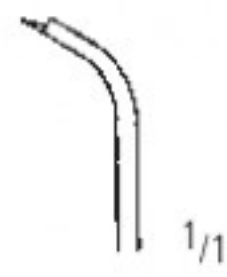

AB 791/09

CASTROVIEJO 1:1
 9,0 cm/3 1/2"



ELSCHNIG 1:2
 AB 792/11
 11,0 cm/4 1/2"



ELSCHNIG 2:3
 AB 793/11
 11,0 cm/4 1/2"

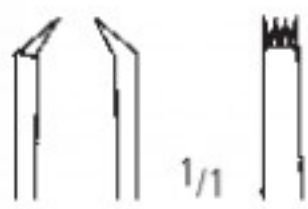

ELSCHNIG 3:4
 AB 794/11
 11,0 cm/4 1/2"



1:2
 AB 796/02



2:3
 AB 796/03

LESTER
 9,0 cm/3 1/2"

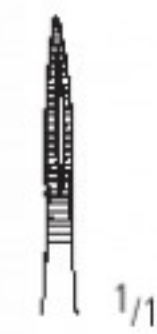

MOORFIELD
 AB 798/10
 10,0 cm/4"

PINZETTEN FORCEPS PINZAS PINCES PINZE

Nahtpinzetten
Suture Forceps
Pinzas para sutura
Pinces pour sutures
Pinze per sutura

AA

AB

AC

AD

AE

AK

AR

KA

KM

KO

KP

KYE

XR

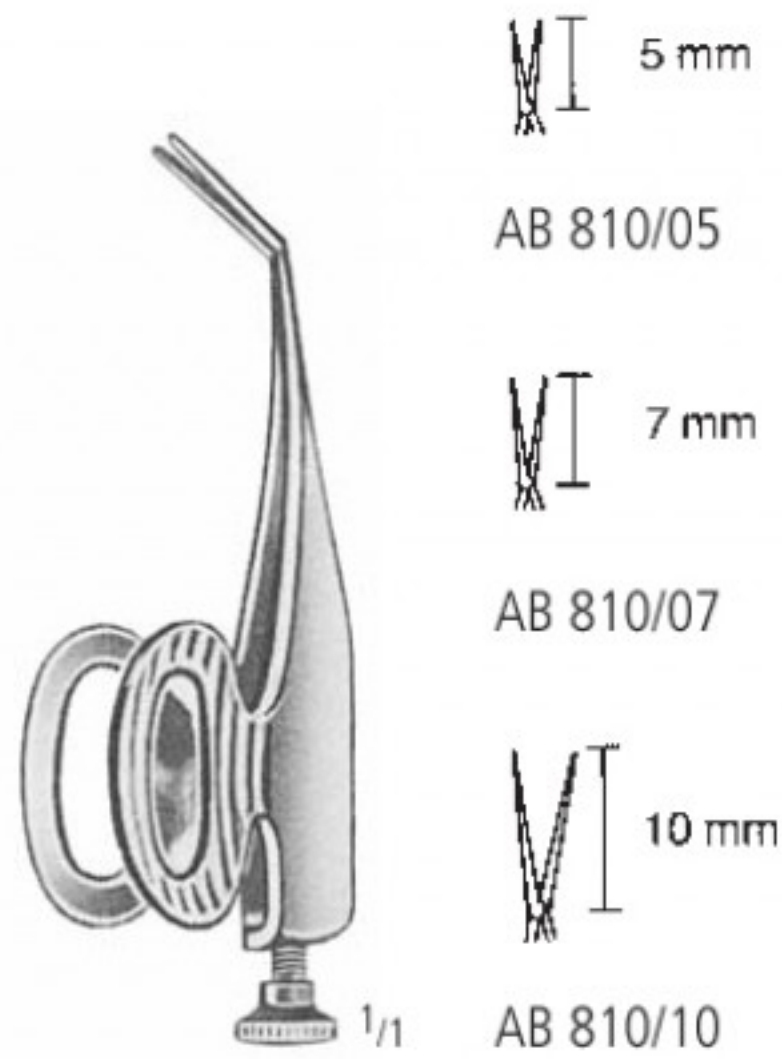

BARRAQUER
5,5 cm/2¹/₄"



ST. MARTIN 1:2
AB 812/07
7,0 cm/2³/₄"

Vorderkammer-Pinzetten
Anterior Chamber Forceps
Pinzas para la cámara anterior
Pinces pour la chambre antérieure
Pinze per la camera anteriore



AB 816/01

0,12 mm
0,30 mm
0,50 mm
1,00 mm
1,50 mm

AB 816/01
AB 816/03
AB 816/05
AB 816/10
AB 816/15

CASTROVIEJO 1:2
10,0 cm/4"

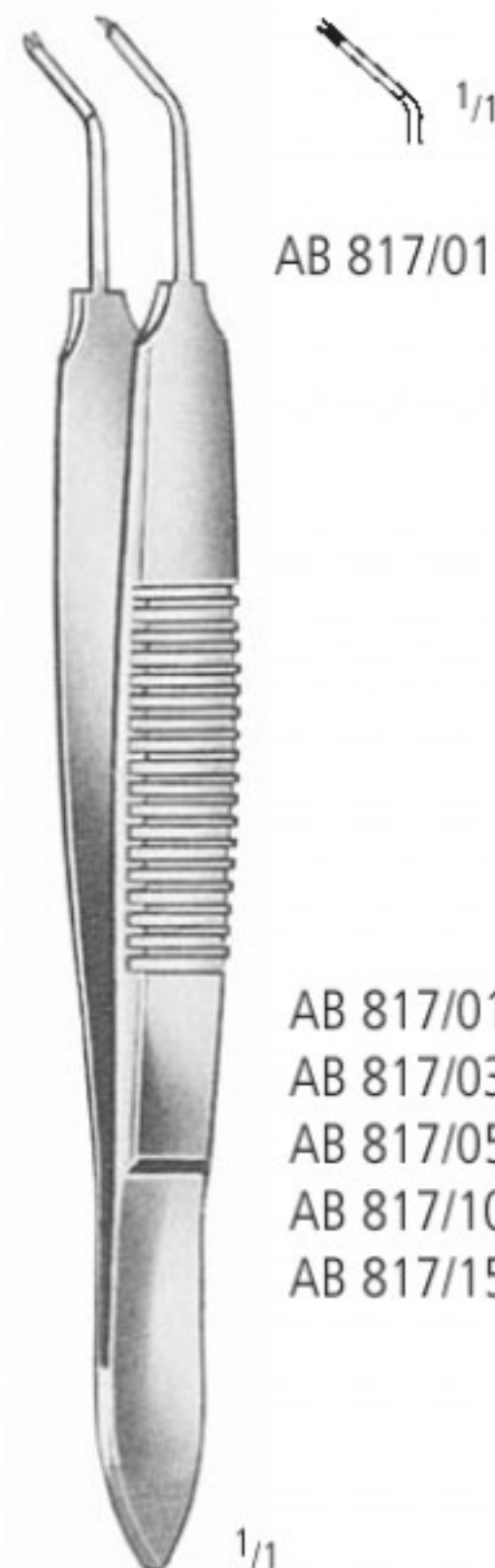

AB 817/01

AB 817/01
AB 817/03
AB 817/05
AB 817/10
AB 817/15

CASTROVIEJO 1:2
10,0 cm/4"

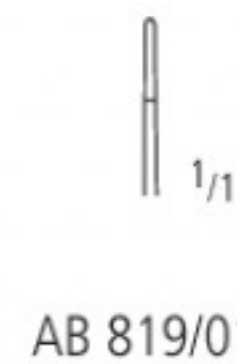

AB 819/01



AB 819/02

McPHERSON
10,0 cm/4"

AB PINZETTEN FORCEPS PINZAS PINCES PINZE

Nahtpinzetten
Suture Forceps
Pinzas para sutura
Pinces pour sutures
Pinze per sutura



KELMAN-McPHERSON 1:2
AB 820/10
10,0 cm/4"



BONACCOLTO
AB 824/01
10,0 cm/4"



BONACCOLTO
AB 824/02
10,0 cm/4"

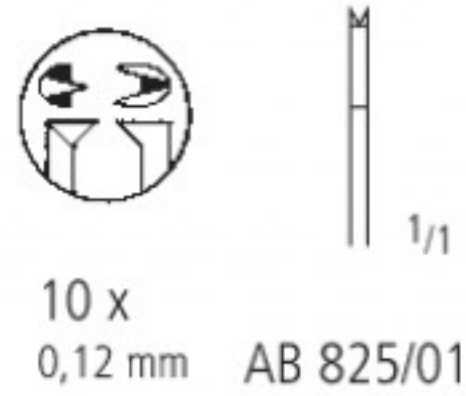

MOD. BONN
10,0 cm/4"

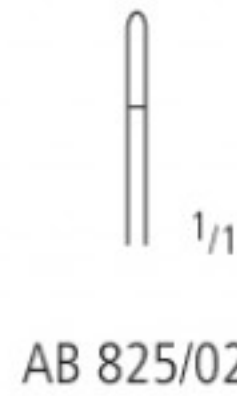

MOD. TÜBINGEN
AB 826/10
10,0 cm/4"

PINZETTEN FORCEPS PINZAS PINCES PINZE

Nahtpinzetten, Fadenpinzetten
 Suture Forceps, Suture Tying Forceps
 Pinzas para sutura, Pinzas de ligadura
 Pincés pour sutures, Pincés à ligature
 Pinze per sutura, Pinze per ligature

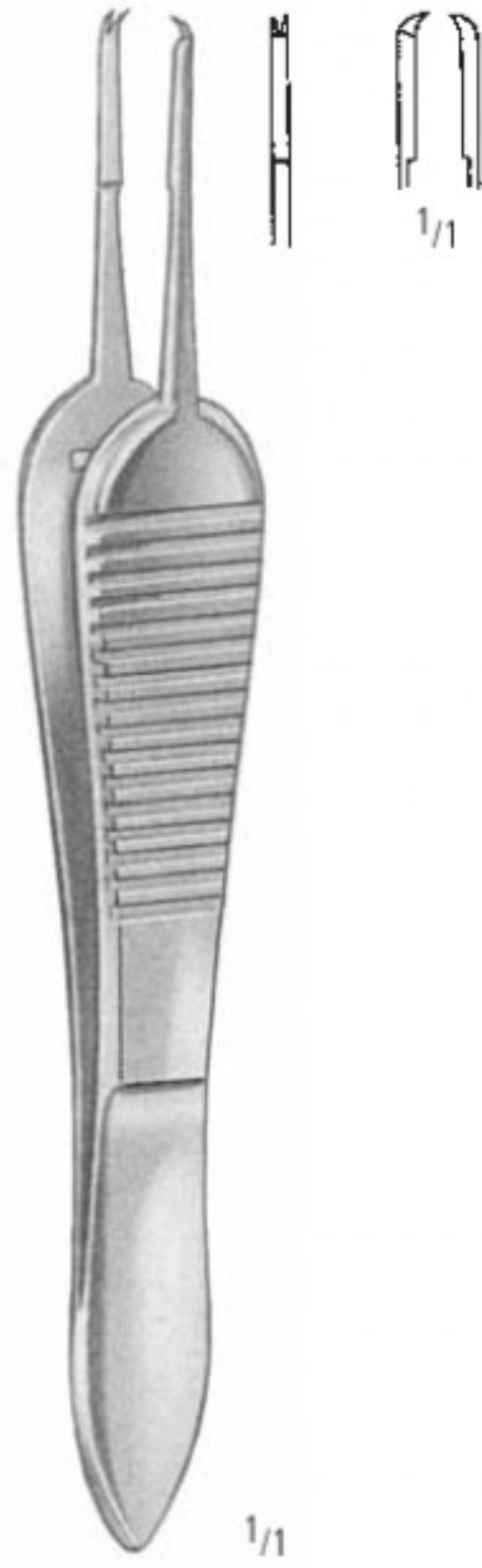

PAUFIQUE 1:2
 AB 828/10
 10,0 cm/4"



HARMS
 AB 829/01
 10,0 cm/4"



HARMS
 AB 829/02
 10,0 cm/4"

AA

AB

AC

AD

AE

AK

AR

KA

KM

KO

KP

KYE

XR

AB PINZETTEN FORCEPS PINZAS PINCES PINZE

Muskelpinzetten
Muscular Forceps
Pinzas musculares
Pincés musculaires
Pinze muscolari

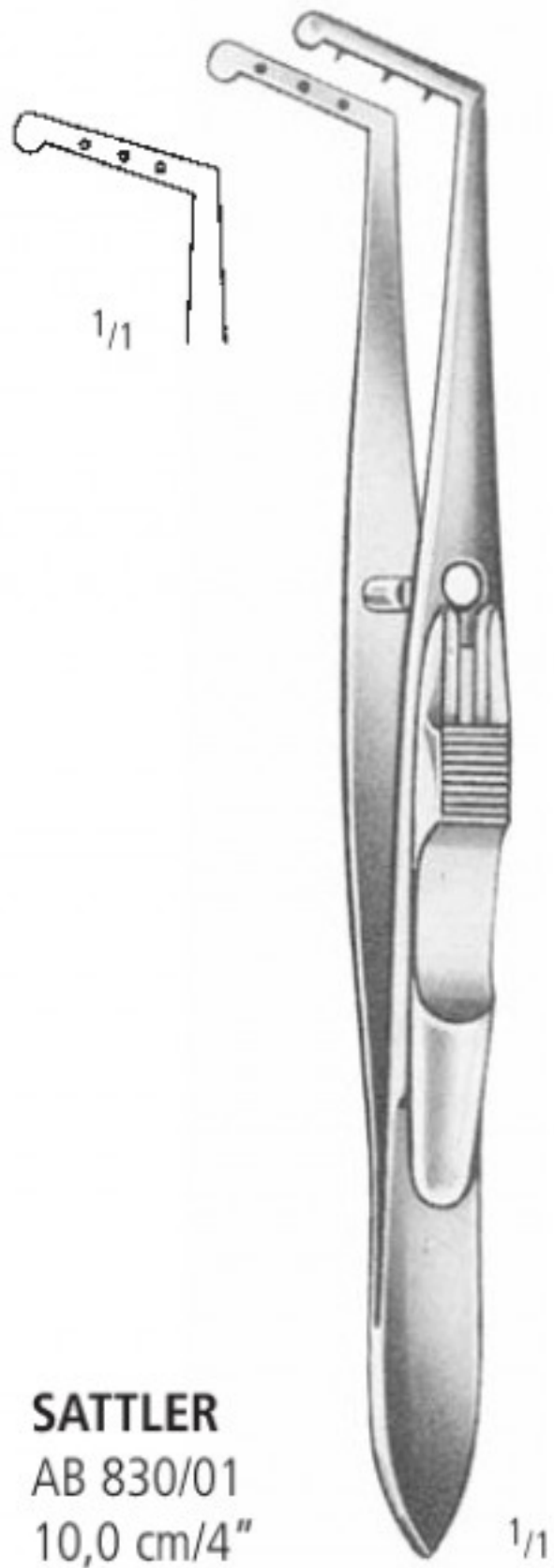

SATTLER
AB 830/01
10,0 cm/4"

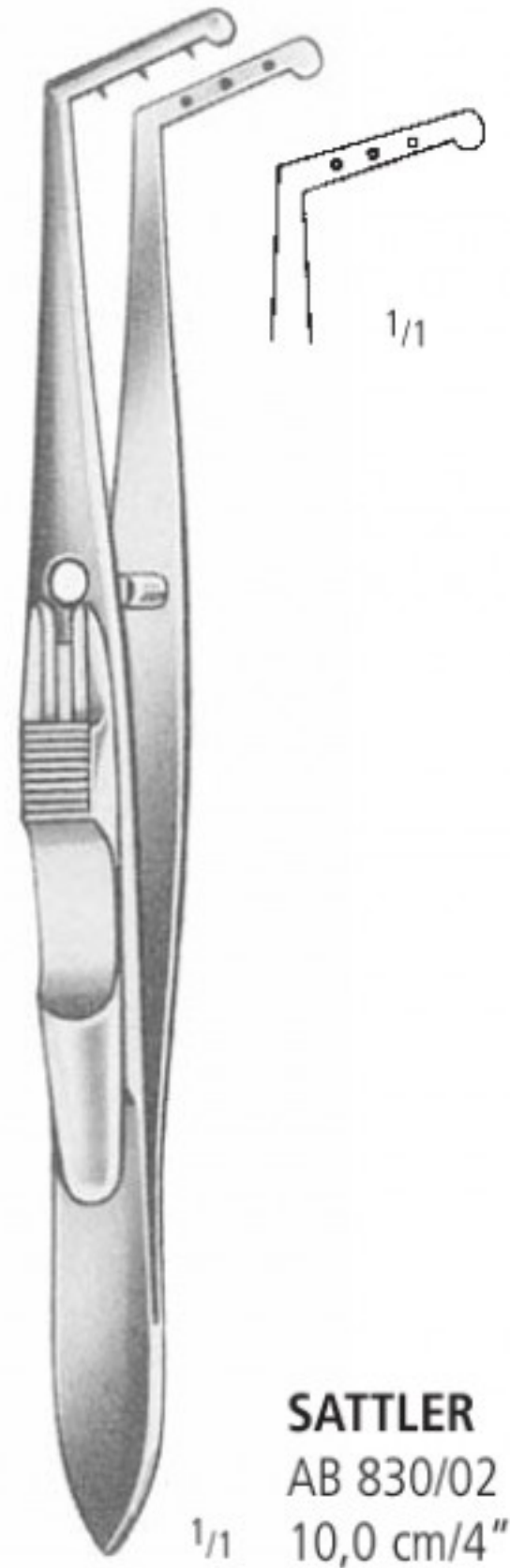

SATTLER
AB 830/02
10,0 cm/4"



BLASCOVICS
AB 832/01
9,0 cm/3 1/2"



BLASCOVICS
AB 832/02
9,0 cm/3 1/2"



JAMESON
AB 833/01
10,0 cm/4"



JAMESON
AB 833/02
10,0 cm/4"



PRINCE
AB 834/01
10,0 cm/4"



PRINCE
AB 834/02
10,0 cm/4"

PINZETTEN FORCEPS PINZAS PINCES PINZE

Muskelpinzetten, Entropium- und Chalazionpinzetten
 Muscular Forceps, Entropium and Chalazion Forceps
 Pinzas musculares, Pinzas de entropión y de chalazión
 Pincers musculaires, Pincers à entropion et à chalazion
 Pinze muscolari, Pinze per palpebre (entropio) e per calazio



BERENS
 AB 835/09
 8,5 cm/3 1/2"



ERHARDT
 AB 836/09
 9,0 cm/3 1/2"



SNELLEN
 AB 837/01
 10,0 cm/4"



SNELLEN
 AB 837/02
 10,0 cm/4"



AYER
 AB 838/01
 9,0 cm/3 1/2"



AYER
 AB 838/02
 9,0 cm/3 1/2"

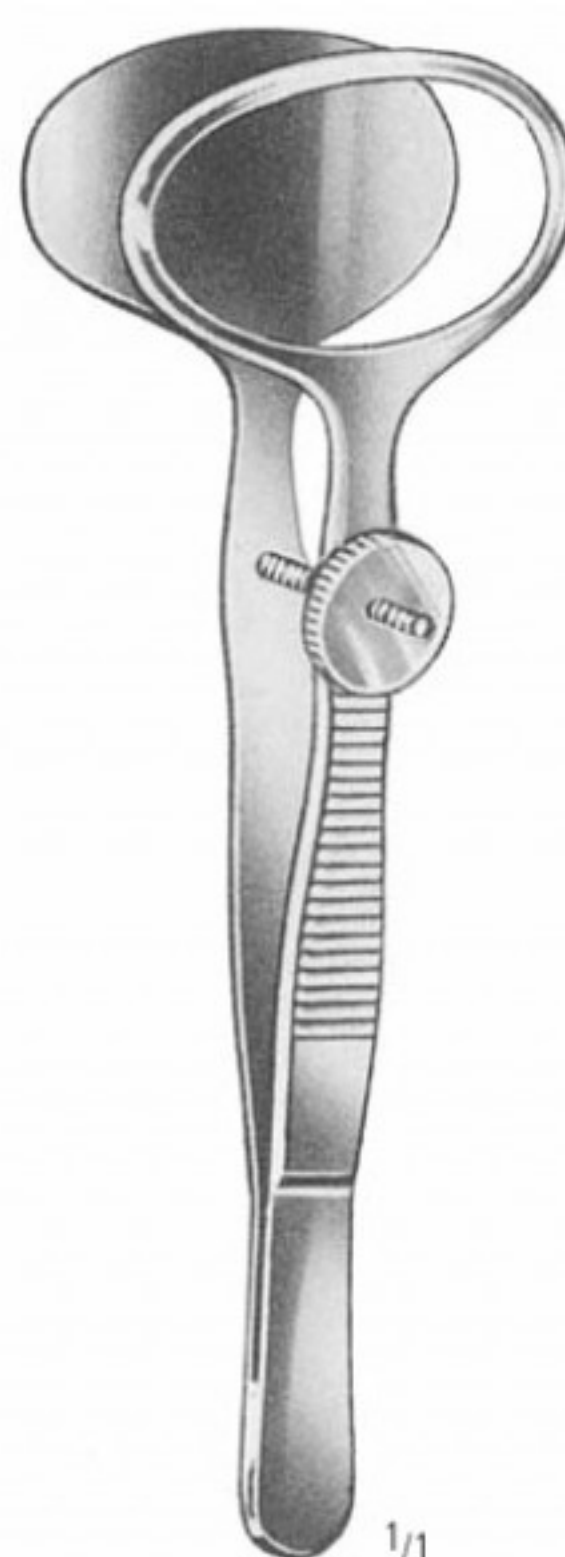

DESMARRES
 9,0 cm/3 1/2"

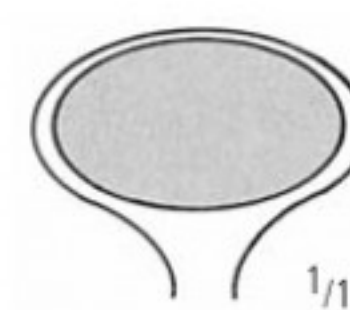

AB 840/01



AB 840/02

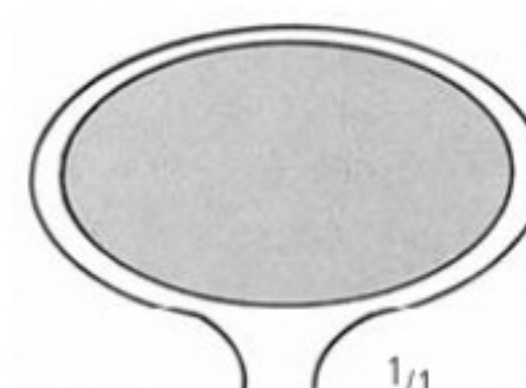

AB 840/03

AA

AB

AC

AD

AE

AK

AR

KA

KM

KO

KP

KYE

XR

AB PINZETTEN FORCEPS PINZAS PINCES PINZE

Chalazionpinzetten, Ptosispinzetten
 Chalazion Forceps, Ptosis Forceps
 Pinzas de chalazión, Pinzas para ptosis
 Pincès à chalazion, Pincès à ptosis
 Pinze per calazio, Pinze per ptosis



LAMBERT
 AB 841/01
 9,0 cm/3 1/2"

1/1



LAMBERT
 AB 841/02
 9,0 cm/3 1/2"

1/1



BERKE
 AB 844/20
 11,0 cm/4 1/2"
 20 mm

1/1



BERKE
 AB 844/27
 11,0 cm/4 1/2"
 27 mm

1/1

PINZETTEN FORCEPS PINZAS PINCES PINZE

Linsenhalte- und Kapsulorhexispinzetten
 Lens Holding and Capsulorhexis Forceps
 Pinzas para tener cristalino y capsulorhexis
 Pinces à tenir de cristallins et capsulorhexis
 Pinze per tenere il cristallino, Pinze capsulorhexis

AA

AB

AC

AD

AE

AK

AR

KA

KM

KO

KP

KYE

XR



FAULKNER
 AB 848/11
 11,0 cm/4 1/2"



McDONALD
 AB 852/01
 10,0 cm/4"



McDONALD
 AB 852/02
 10,0 cm/4"

SCHEREN
SCISSORS
TIJERAS
CISEAUX
FORBICI

AC

nopa[®] instruments



SCHEREN SCISSORS TIJERAS CISEAUX FORBICI

Feine Scheren, Augenscheren
 Fine Scissors, Eye Scissors
 Tijeras finas, Tijeras oculares
 Ciseaux fins, Ciseaux oculaires
 Forbici fini, Forbici oftalmologici

AA

AB

AC

AD

AE

AK

AR

KA

KM

KO

KP

KYE

XR

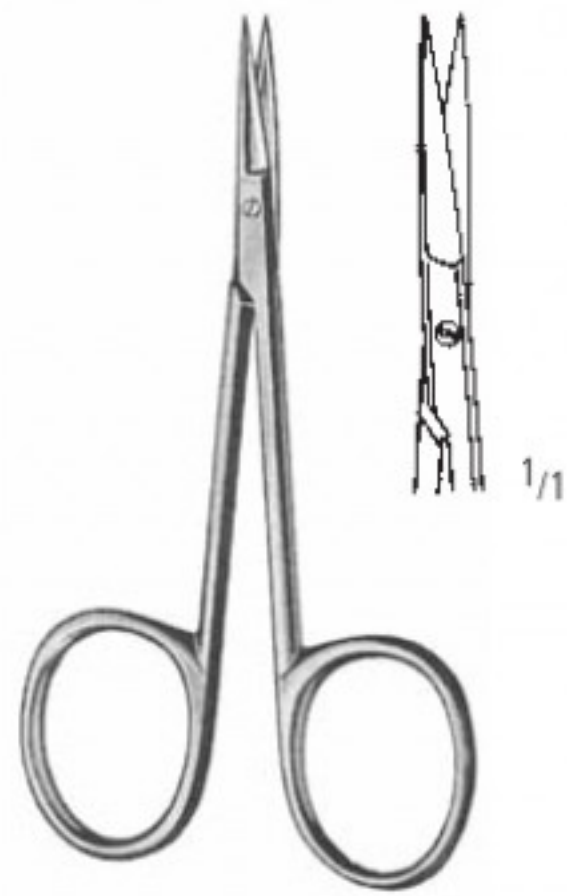

AC 430/08
 8,0 cm/3 1/4"

MOD. BONN

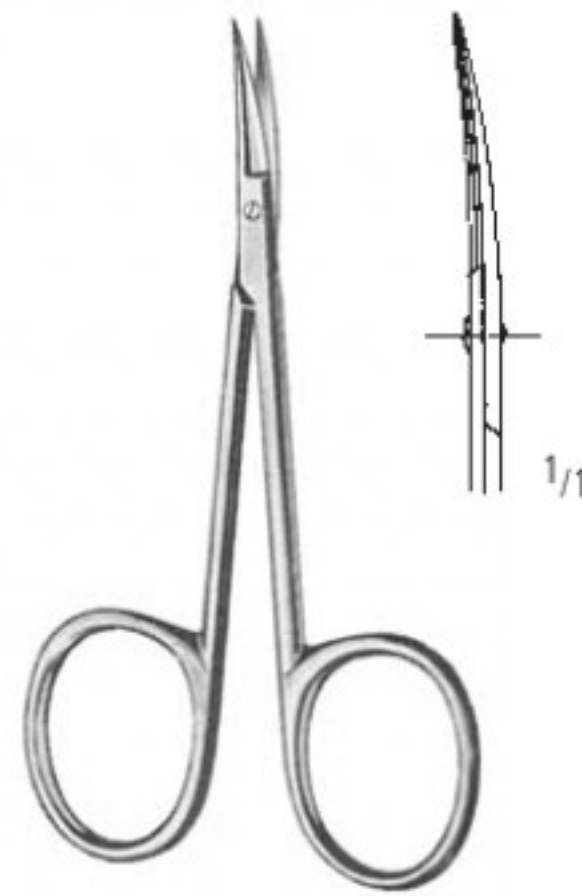

AC 431/08
 8,0 cm/3 1/4"



11,5 cm/4 1/2"

Fig. 1

gerade
 straight
 rectas
 droits
 rette

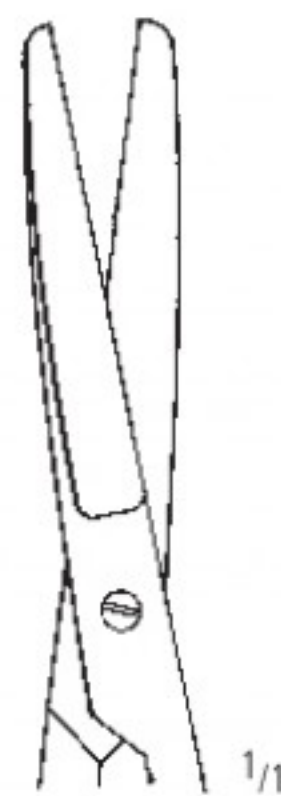

AC 446/01

Fig. 2

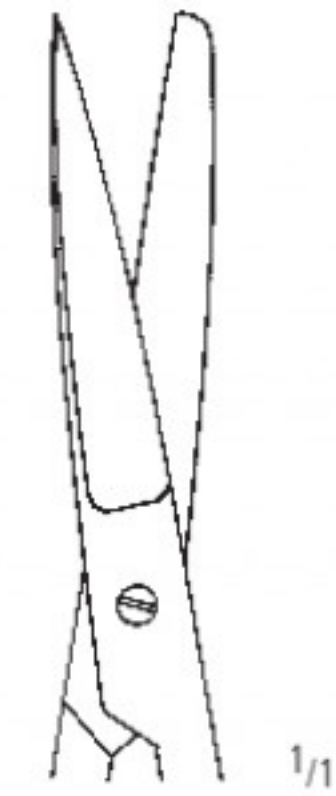

AC 446/02

Fig. 1

gebogen
 curved
 curvas
 courbes
 curve



AC 447/01

Fig. 2



AC 447/02

Augenscheren
 Eye Scissors
 Tijeras oculares
 Ciseaux oculaires
 Forbici oftalmologici



AC 448/11
 11,5 cm/4 1/2"



AC 449/11
 11,5 cm/4 1/2"

Irisscheren
 Iris Scissors
 Tijeras para iridectomia
 Ciseaux à iridectomie
 Forbici per iridectomia

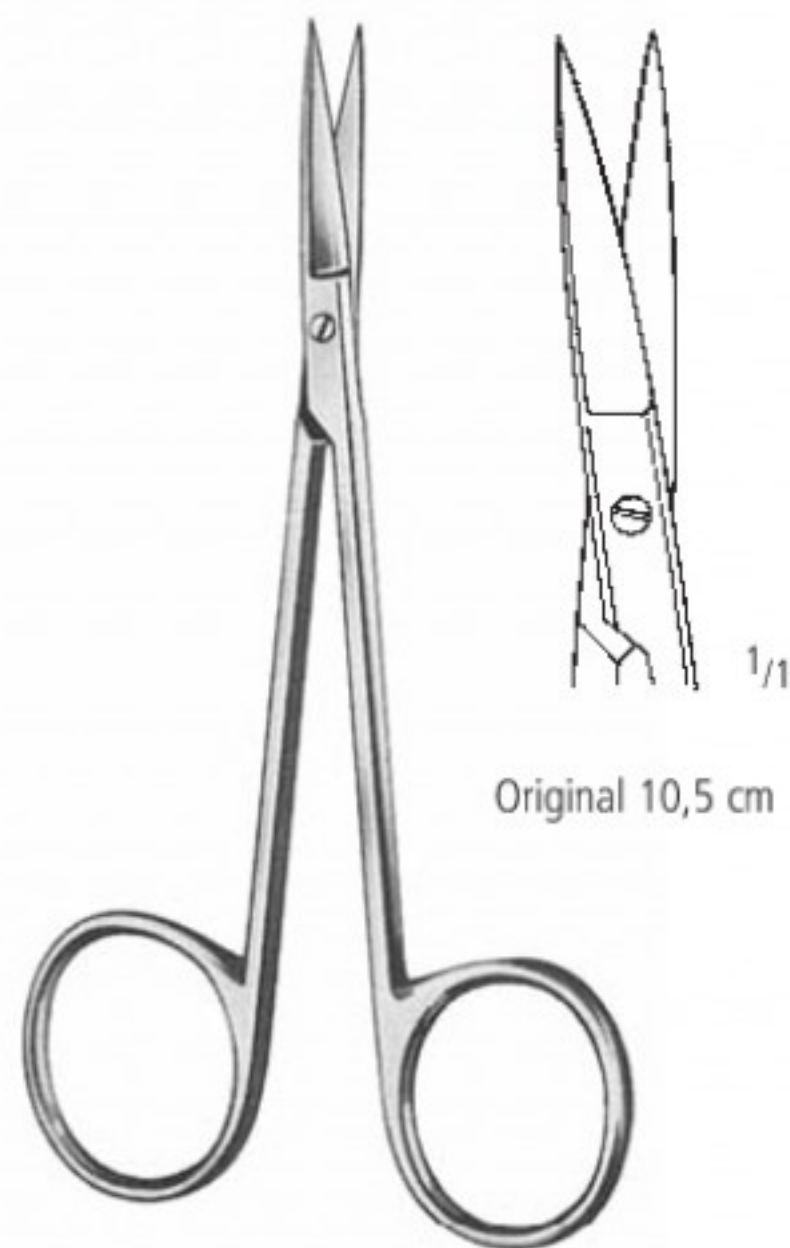

9,0 cm/3 1/2"
 10,5 cm/4 1/4"
 11,5 cm/4 1/2"

AC 450/09
 AC 450/10
 AC 450/11

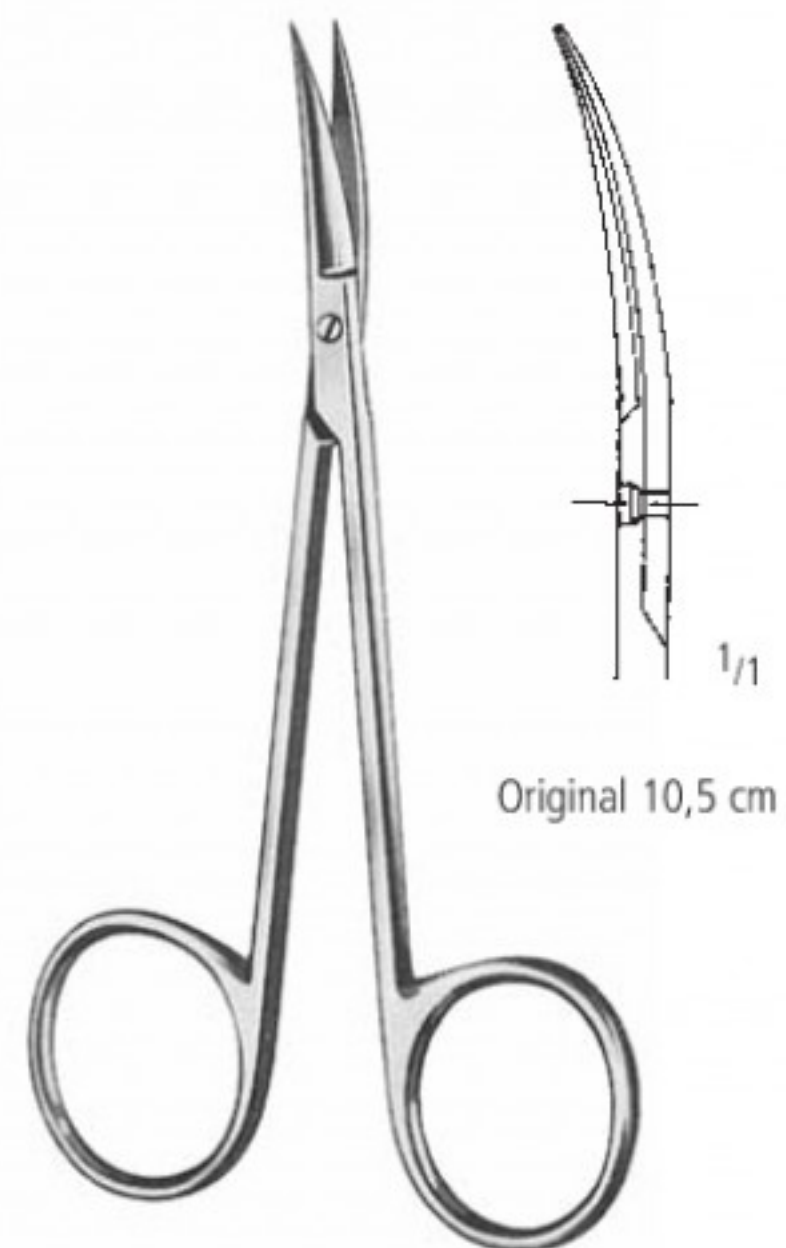

AC 451/09
 AC 451/10
 AC 451/11

SCHEREN SCISSORS TIJERAS CISEAUX FORBICI

Augenscheren
Eye Scissors
Tijeras oculares
Ciseaux oculaires
Forbici oftalmologici

AA

AB

AC

AD

AE

AK

AR

KA

KM

KO

KP

KYE

XR

Strabimusscheren
Strabismus Scissors
Tijeras para estrabismos
Ciseaux à strabisme
Forbici per strabismo



AC 460/11
11,5 cm/4 1/2"

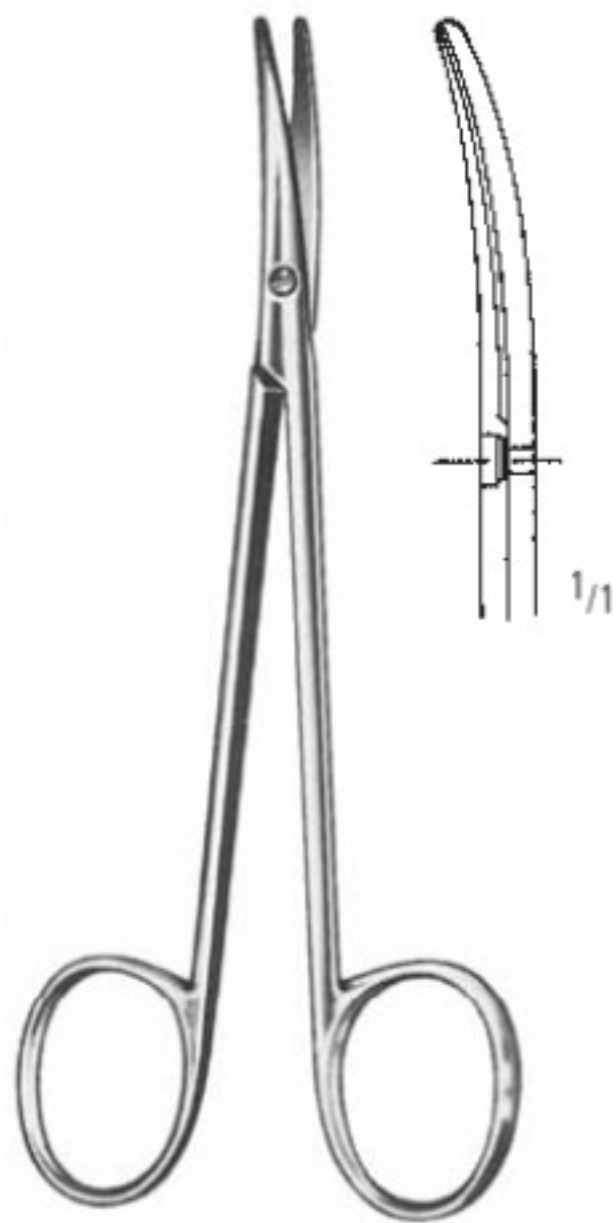

AC 461/11
11,5 cm/4 1/2"

mit großen Ringen
with large bows
con anillos grandes
avec grands anneaux
con anelli grandi

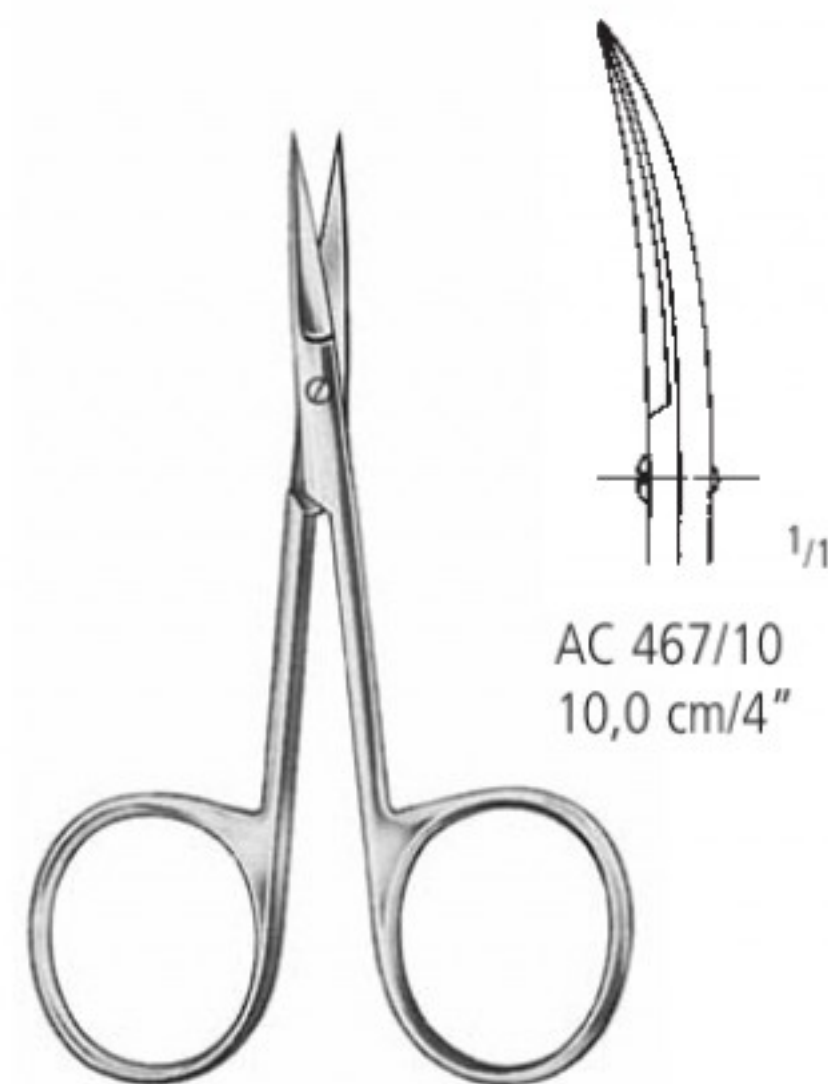

AC 466/10
10,0 cm/4"

AC 467/10
10,0 cm/4"

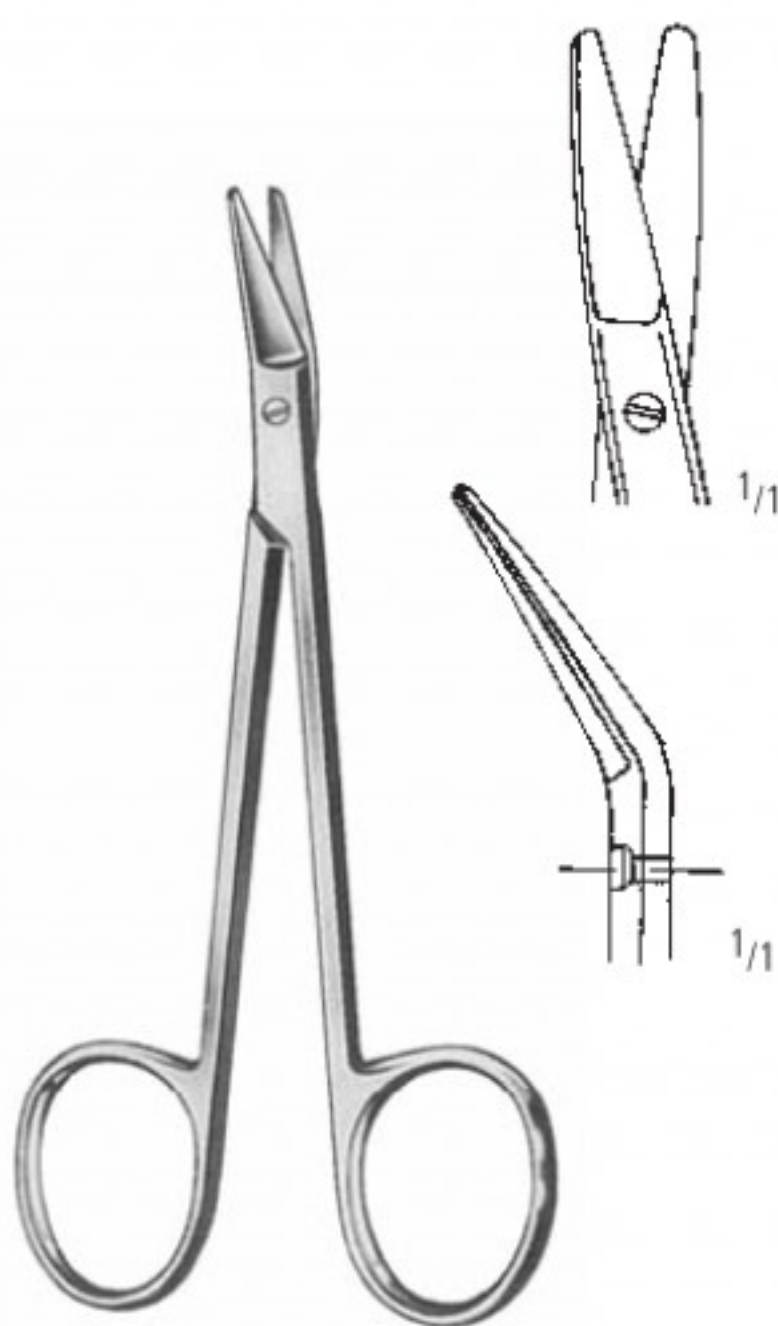

GRAEFE
AC 469/10
10,5 cm/4 1/4"

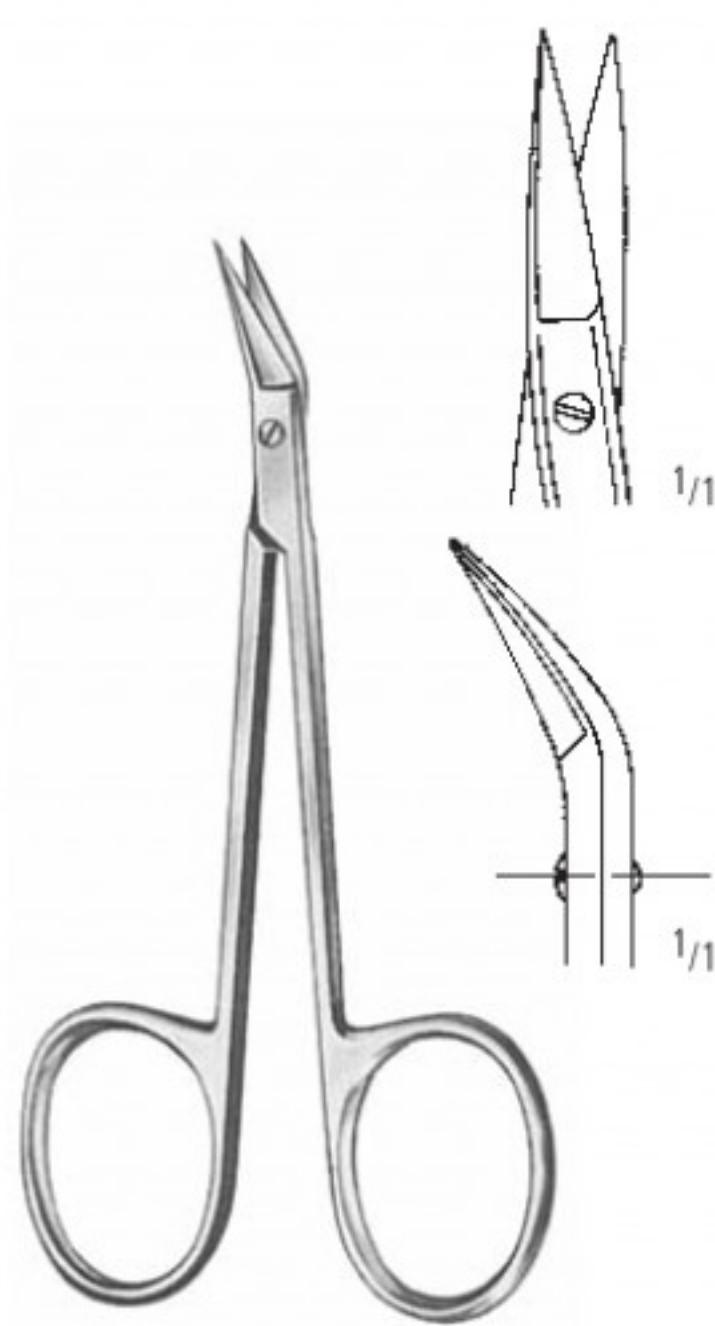

WILMER
AC 471/10
10,0 cm/4"

AC SCHEREN SCISSORS TIJERAS CISEAUX FORBICI

Augenscheren
Eye Scissors
Tijeras oculares
Ciseaux oculaires
Forbici oftalmologici



LA GRANGE
AC 472/11
11,5 cm/4¹/₂"

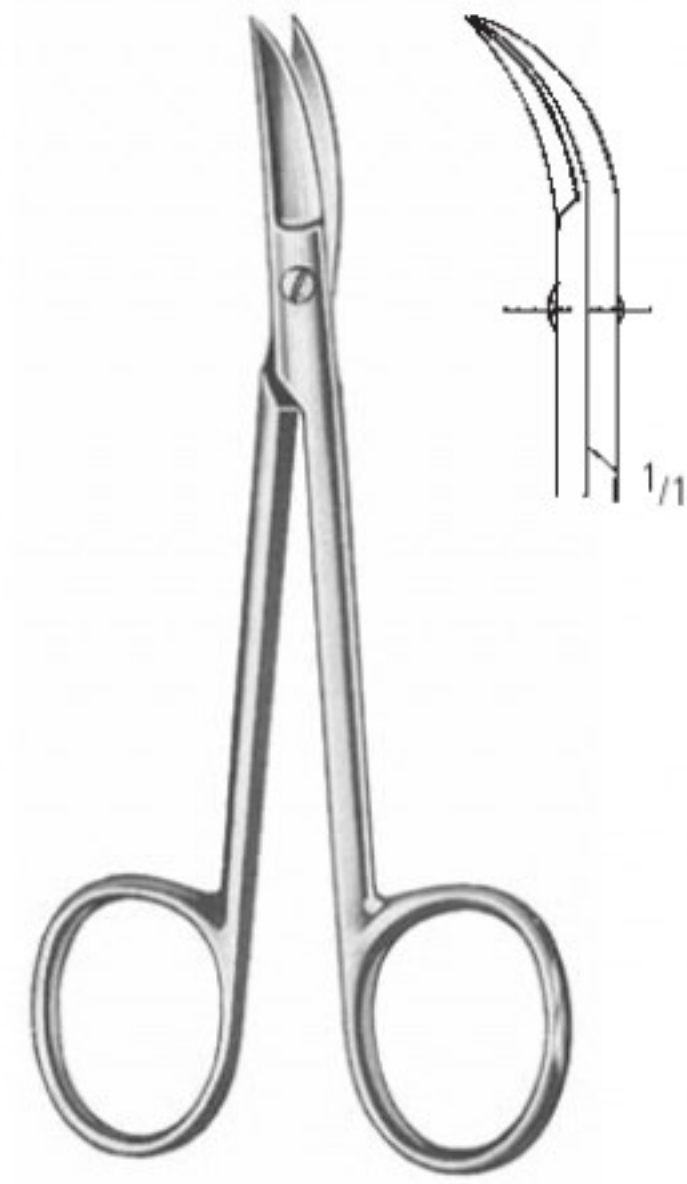

CHADWICK
AC 473/11
11,0 cm/4¹/₄"

Sehnenscheren
Tenotomy Scissors
Tijeras para tenotomía
Ciseaux à ténotomie
Forbici per tenotomia



STEVENS
10,5 cm/4¹/₈"
11,5 cm/4¹/₂"

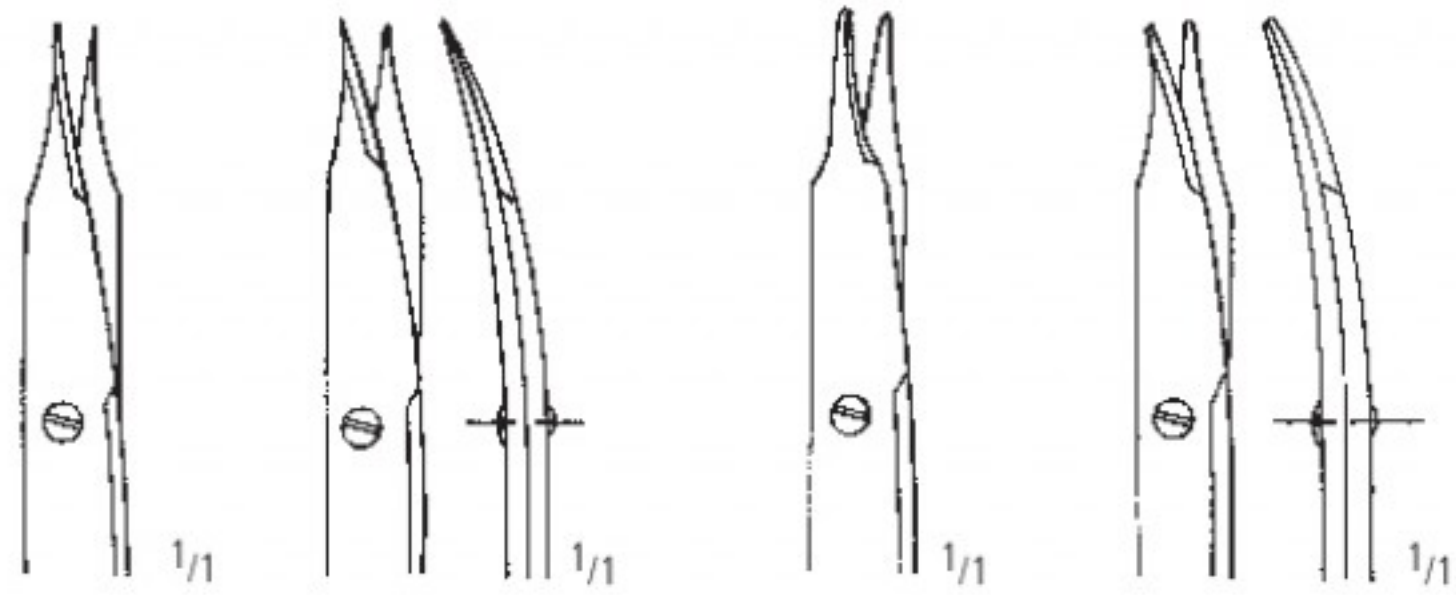

spitz
agudas
pointed
pointues
acuta

Original 11,5 cm

stumpf
romas
blunt
mousses
smussa

gerade
straight
rectas
droits
rette

gebogen
curved
curvas
courbes
curve

gerade
straight
rectas
droits
rette

gebogen
curved
curvas
courbes
curve

AC 474/10
AC 474/11

AC 475/10
AC 475/11

AC 476/10
AC 476/11

AC 477/10
AC 477/11

SCHEREN SCISSORS TIJERAS CISEAUX FORBICI

Augenscheren
Eye Scissors
Tijeras oculares
Ciseaux oculaires
Forbici oftalmologici

AA

AB

AC

AD

AE

AK

AR

KA

KM

KO

KP

KYE

XR

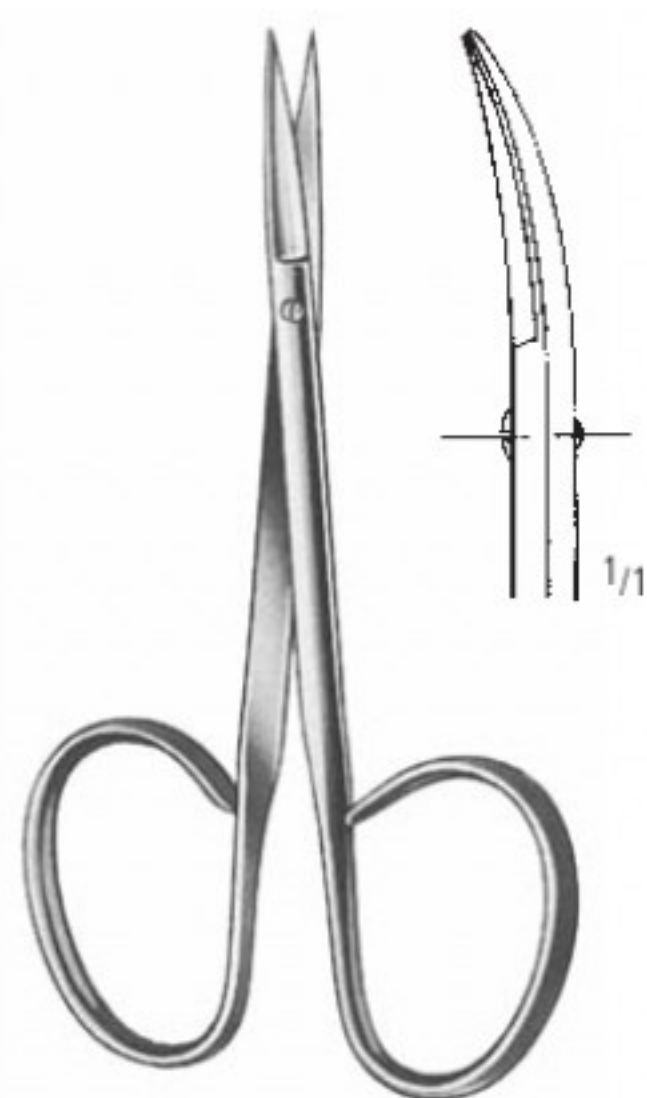

gerade
straight
rectas
droits
rette

gebogen
curved
curvas
courbes
curve

RIBBON
10,0 cm/4"

AC 488/10 AC 489/10

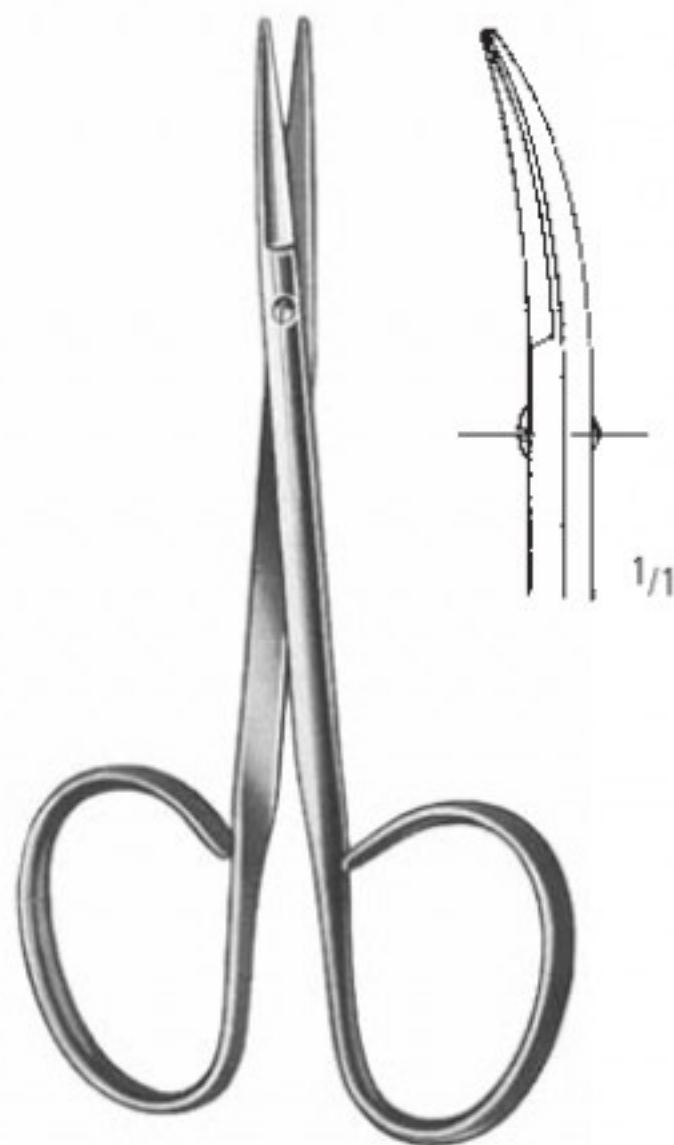

gerade
straight
rectas
droits
rette

gebogen
curved
curvas
courbes
curve

RIBBON
10,0 cm/4"

AC 490/10 AC 491/10

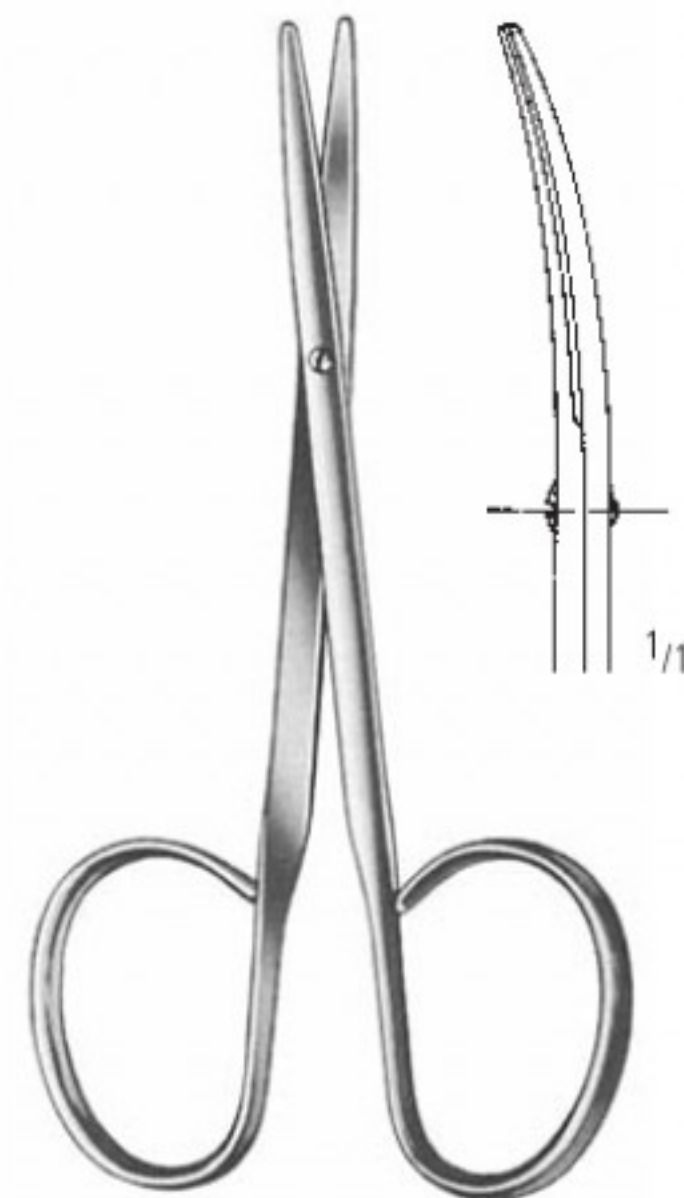

gerade
straight
rectas
droits
rette

gebogen
curved
curvas
courbes
curve

RIBBON
10,0 cm/4"

AC 492/10 AC 493/10

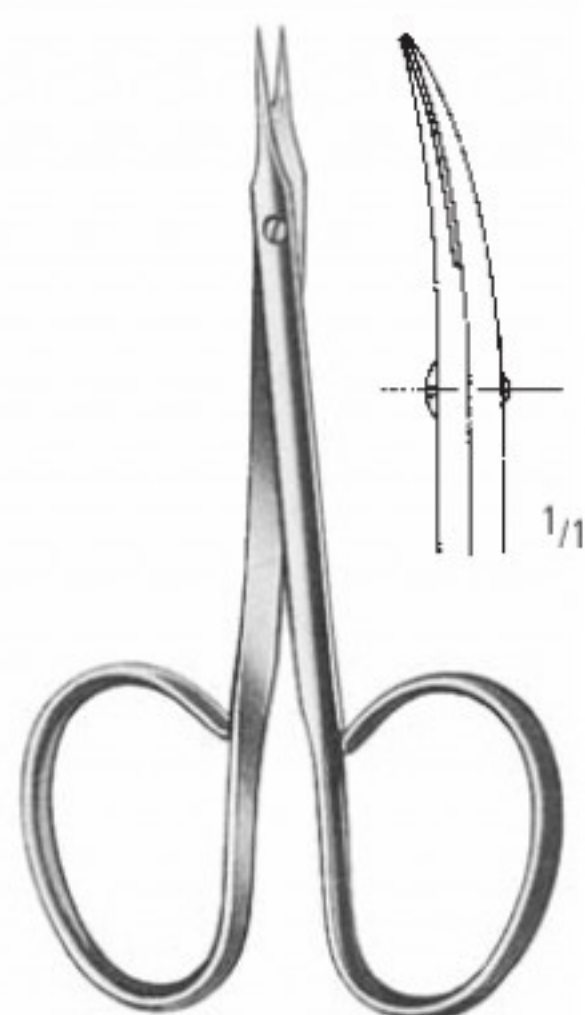

gerade
straight
rectas
droits
rette

gebogen
curved
curvas
courbes
curve

RIBBON
9,5 cm/3³/₄"

AC 494/09 AC 495/09

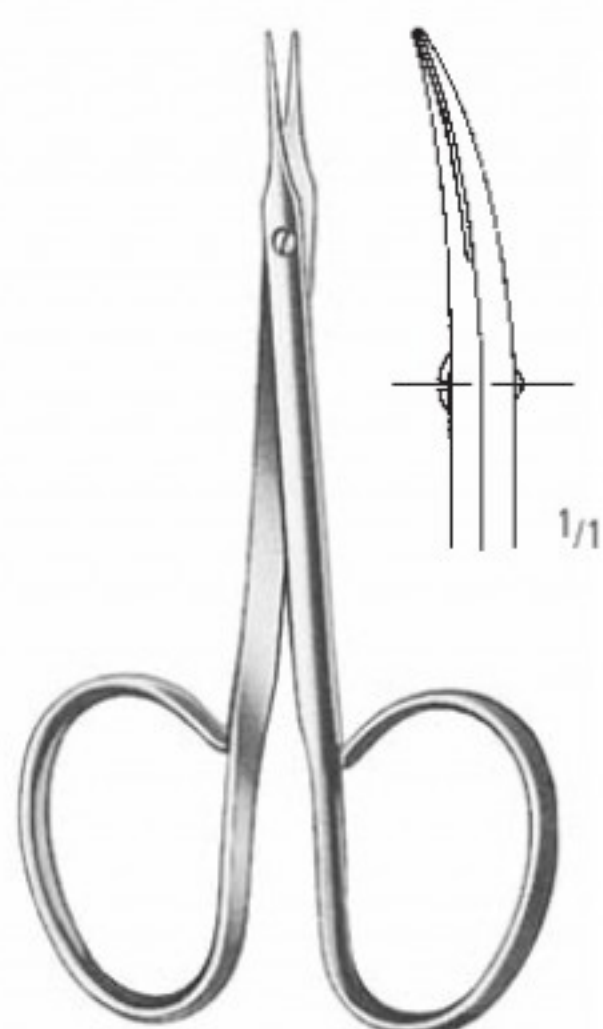

gerade
straight
rectas
droits
rette

gebogen
curved
curvas
courbes
curve

RIBBON
9,5 cm/3³/₄"

AC 496/09 AC 497/09

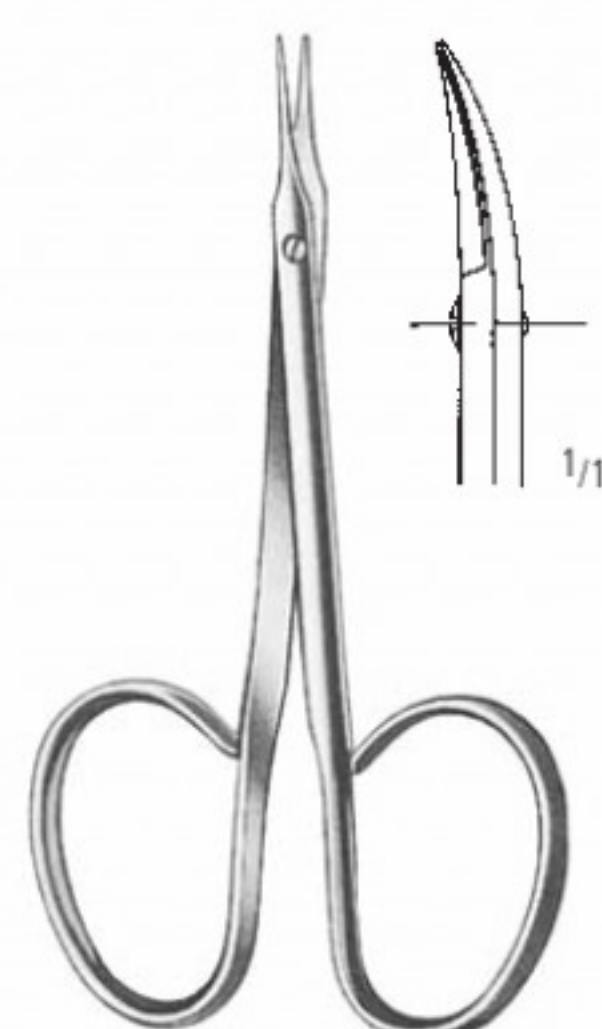

gerade
straight
rectas
droits
rette

gebogen
curved
curvas
courbes
curve

RIBBON
9,5 cm/3³/₄"

AC 498/09 AC 499/09

AC SCHEREN SCISSORS TIJERAS CISEAUX FORBICI

Ligaturscheren, Iridektomiescheren
 Ligature Scissors, Iris Scissors
 Tijeras para ligaduras, Pinzas-tijeras para iridectomía
 Ciseaux à ligatures, Ciseaux à iridectomie
 Forbici per legatura, Forbici per iridectomia



SPENCER
 9,5 cm/3¹/₂" AC 500/09
 10,5 cm/4¹/₄" AC 500/10

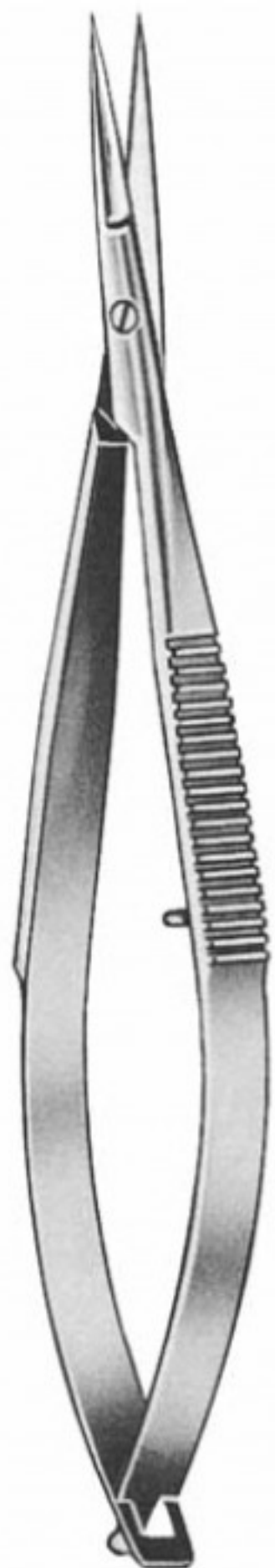

NOYES
 12,0 cm/4³/₄"

Fig.1 AC 750/12
 Fig.2 AC 752/12
 Fig.3 AC 754/12

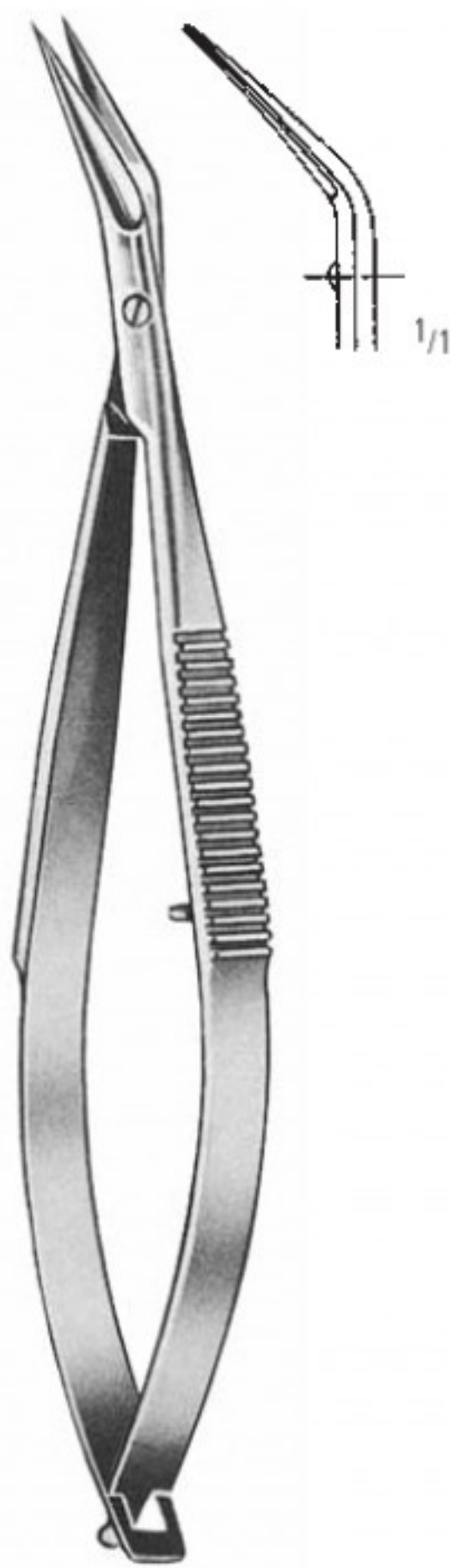

AC 751/12
 AC 753/12
 AC 755/12

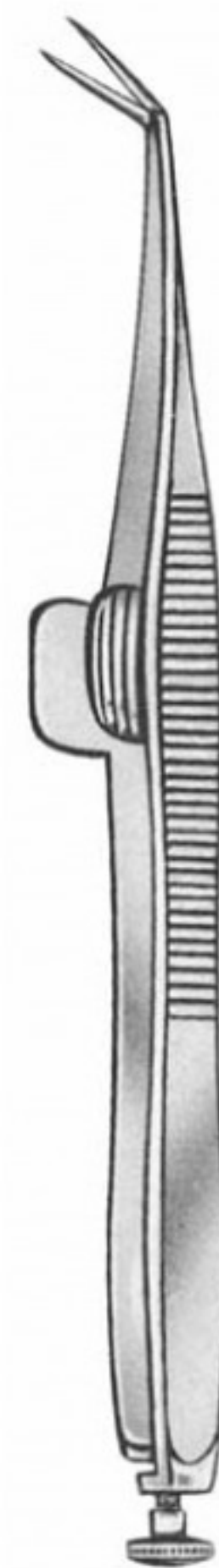

AC 760/11



AC 762/11



AC 764/11

WECKER
 11,0 cm/4¹/₂"

SCHEREN SCISSORS TIJERAS CISEAUX FORBICI

Iridektomiescheren
Iris Scissors
Pinzas-tijeras para iridectomía
Ciseaux à iridectomie
Forbici per iridectomia

AA

AB

AC

AD

AE

AK

AR

KA

KM

KO

KP

KYE

XR



BARRAQUER
5,5 cm/2 1/4"

- 5 mm AC 768/05
- 7 mm AC 768/07
- 10 mm AC 768/10

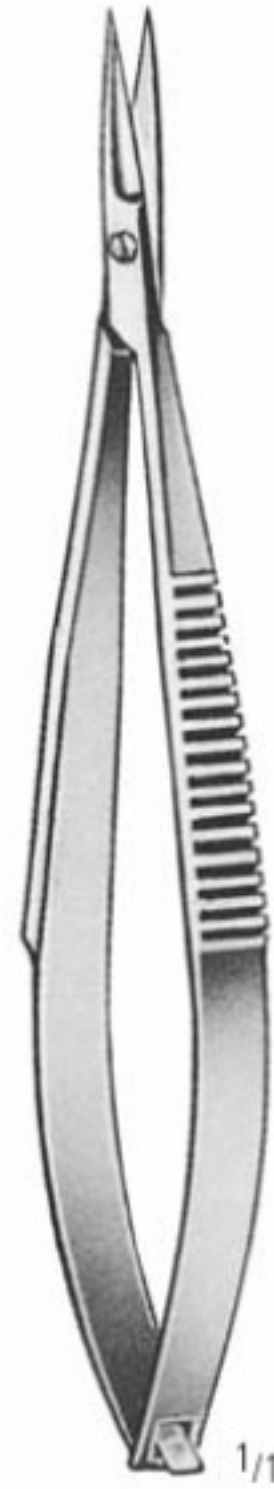

CASTROVIEJO
AC 770/00
9,0 cm/3 1/2"



AC 770/02

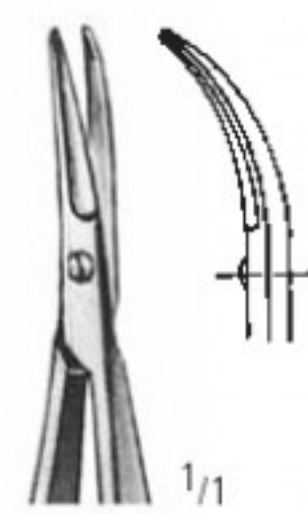

AC 770/03



AC 771/09



AC 772/09

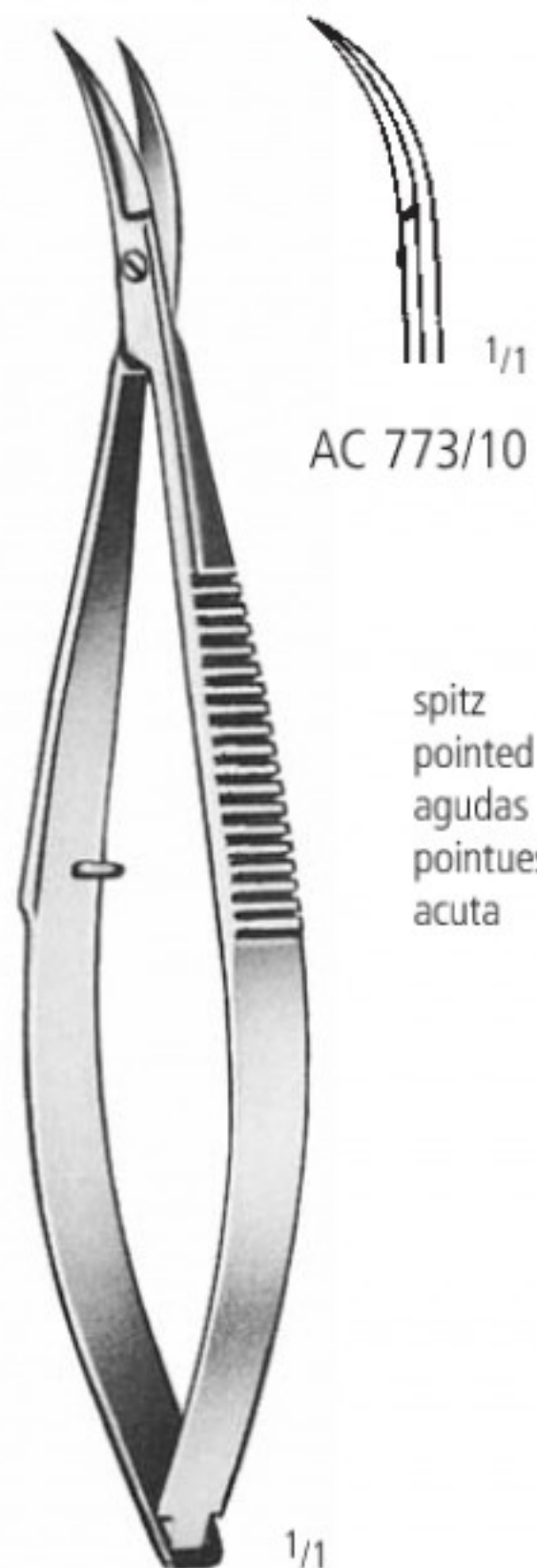

AC 773/10

spitz
pointed
agudas
pointues
acuta

CASTROVIEJO
10,0 cm/4"

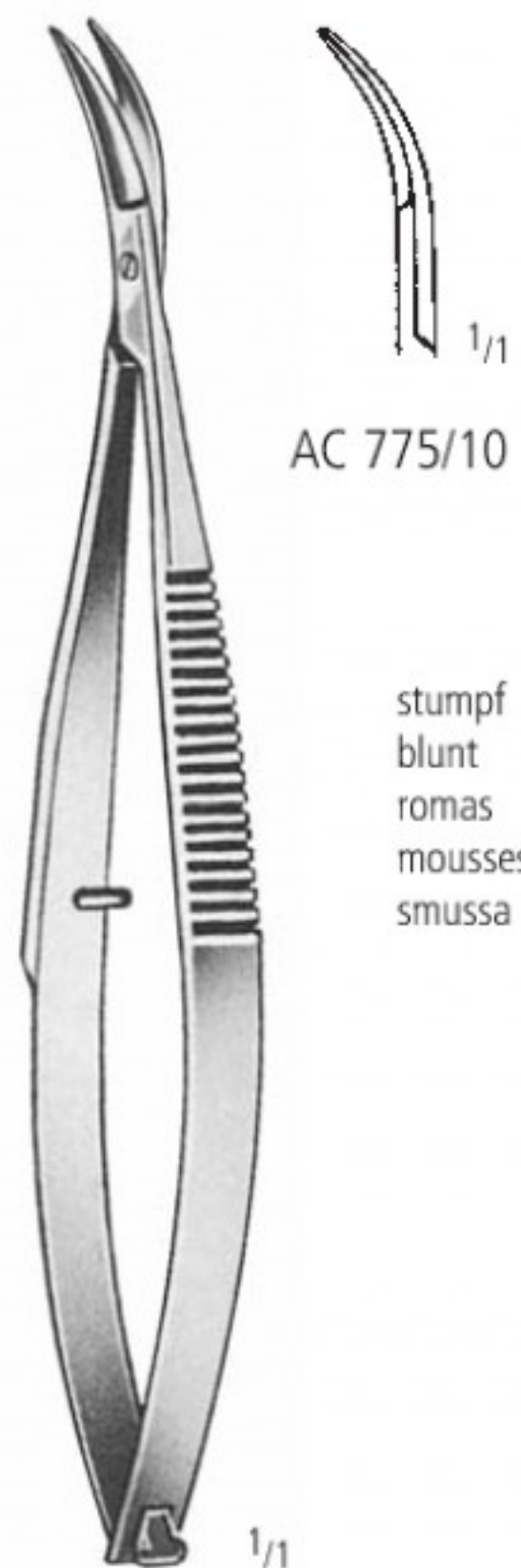

AC 775/10

stumpf
blunt
romas
mousses
smussa

CASTROVIEJO
10,0 cm/4"

AC SCHEREN SCISSORS TIJERAS CISEAUX FORBICI

Nachstarscheren
 Secondary Cataract Scissors
 Pinzas-tijeras para catarata secundaria
 Pincis ciseaux pour le cataracte secondaire
 Pinze-forbici per cataratta secondaria

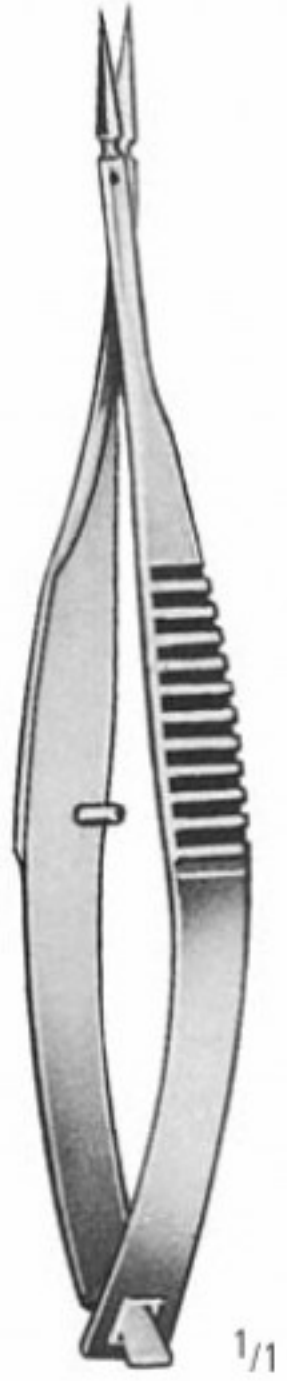

gerade
 straight
 rectas
 droits
 rette

AC 776/01
 8,5 cm/3 1/2"

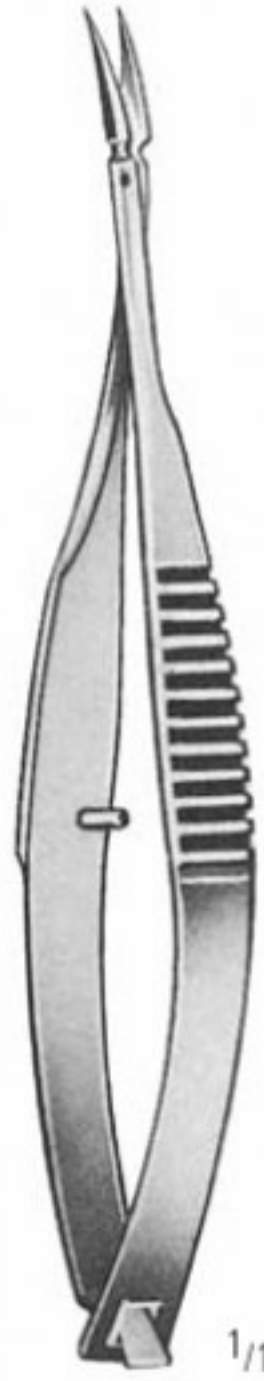

gebogen
 curved
 curvas
 courbes
 curve

AC 776/02
 8,5 cm/3 1/2"

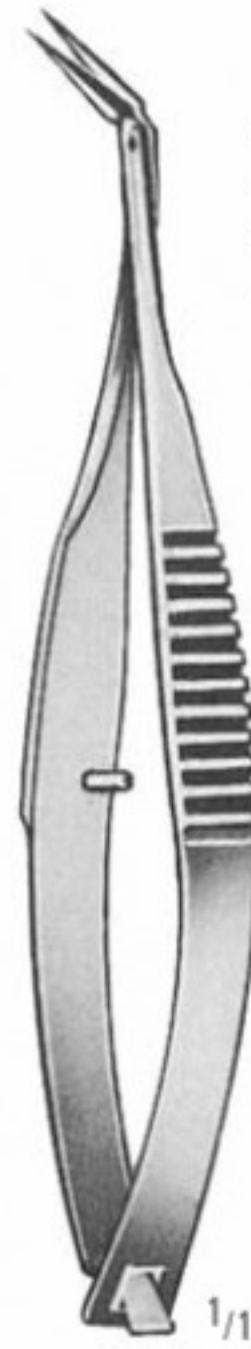

kniegebogen
 angular
 acodadas
 coudés
 angolato

AC 776/03
 8,5 cm/3 1/2"

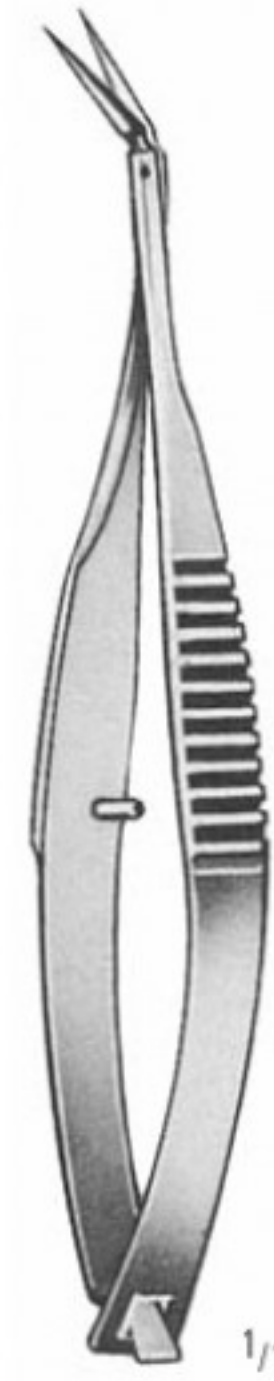

aufgewinkelt
 angled on flat
 acodadas hacia arriba
 coudés vers le haut
 angolato in alto

AC 776/04
 8,5 cm/3 1/2"

VANNAS MOD. TÜBINGEN

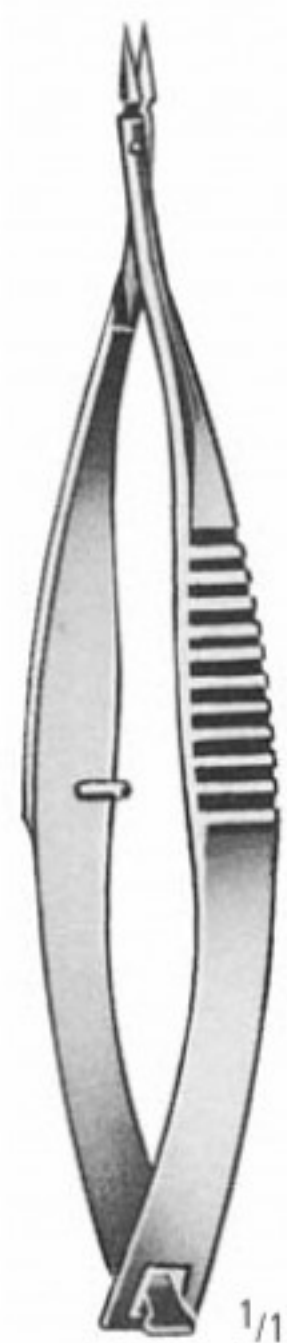

gerade
 straight
 rectas
 droits
 rette

VANNAS
 AC 778/01
 8,0 cm/3 1/4"

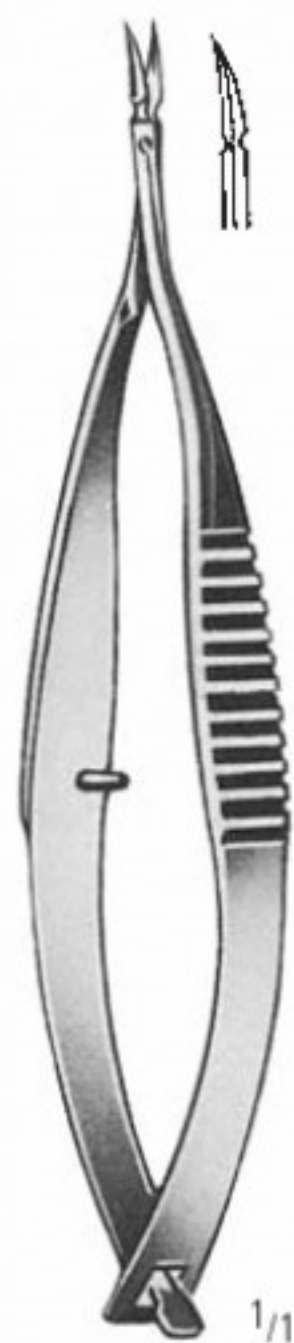

gebogen
 curved
 curvas
 courbes
 curve

VANNAS
 AC 778/02
 8,0 cm/3 1/4"

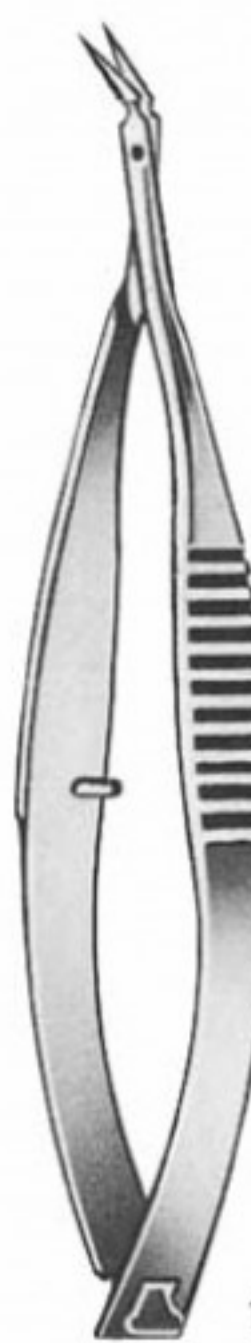

kniegebogen
 angular
 acodadas
 coudés
 angolato

VANNAS
 AC 778/03
 8,0 cm/3 1/4"

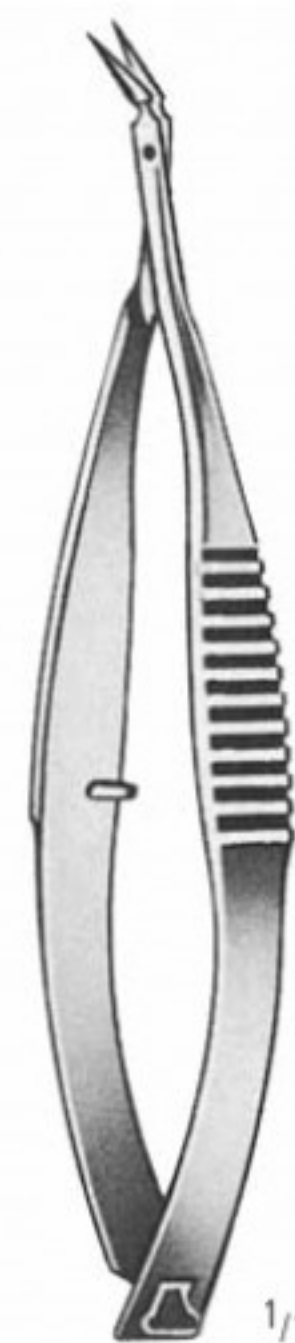

aufgewinkelt
 angled on flat
 acodadas hacia arriba
 coudés vers le haut
 angolato in alto

VANNAS
 AC 778/04
 8,0 cm/3 1/4"

SCHEREN SCISSORS TIJERAS CISEAUX FORBICI

Nachstarscheren, Sehnenscheren, Hornhautscheren
 Secondary Cataract Scissors, Tenotomy Scissors, Corneal Scissors
 Pinzas-tijeras para catarata secundaria, Pinzas-tijeras para tenotomía y córnea
 Pincis ciseaux pour le cataracte secondaire, Ciseaux à ténotomie, Ciseaux corneales
 Pinze-forbici per cataratta secondaria, Forbici per tenotomia e per cornea

AA

AB

AC

AD

AE

AK

AR

KA

KM

KO

KP

KYE

XR



GILLS-WELSH
8,5 cm/3 1/2"



AC 779/01



AC 779/02

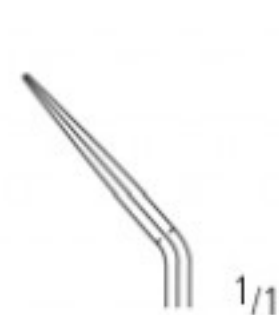

AC 779/03

kniegebogen
angular
acodadas
coudés
angolato



AC 779/04

aufgewinkelt
angled on flat
acodadas hacia arriba
coudés vers le haut
angolato in alto



WESTCOTT
AC 780/11
11,0 cm/4 1/2"

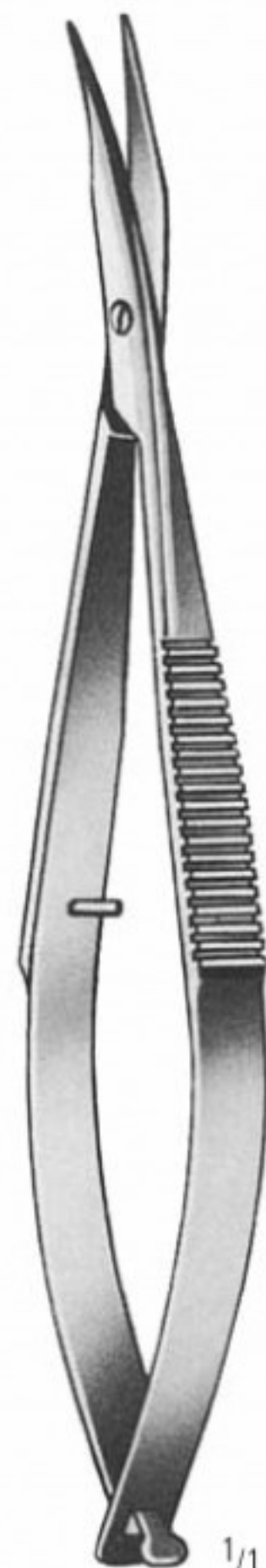

WESTCOTT
AC 782/11
11,0 cm/4 1/2"

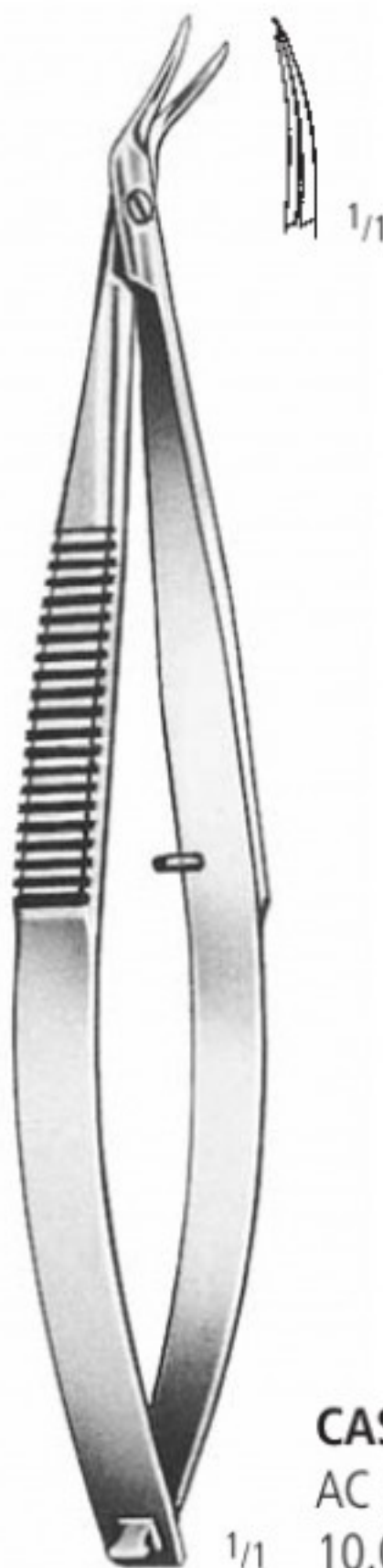

CASTROVIEJO
AC 785/01
10,0 cm/4"

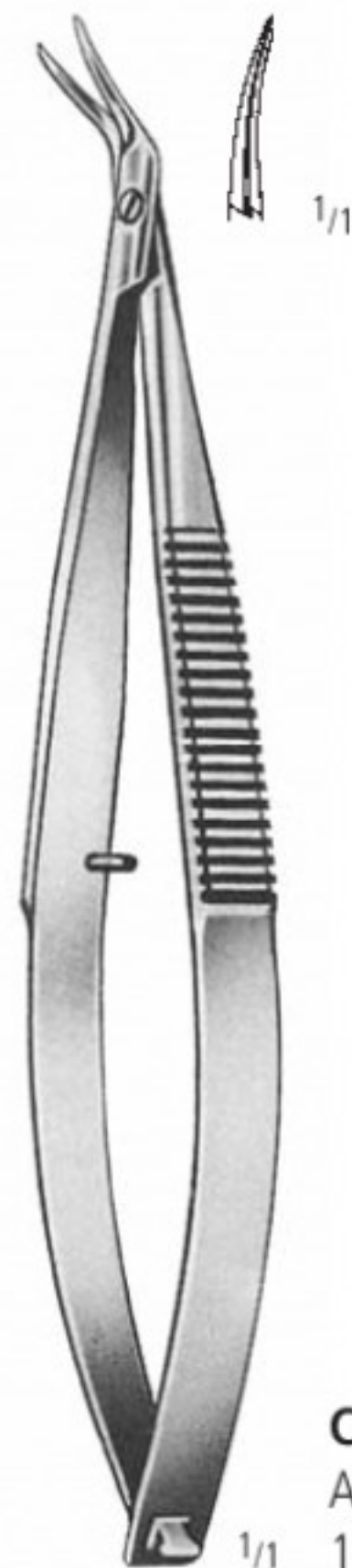

CASTROVIEJO
AC 785/02
10,0 cm/4"

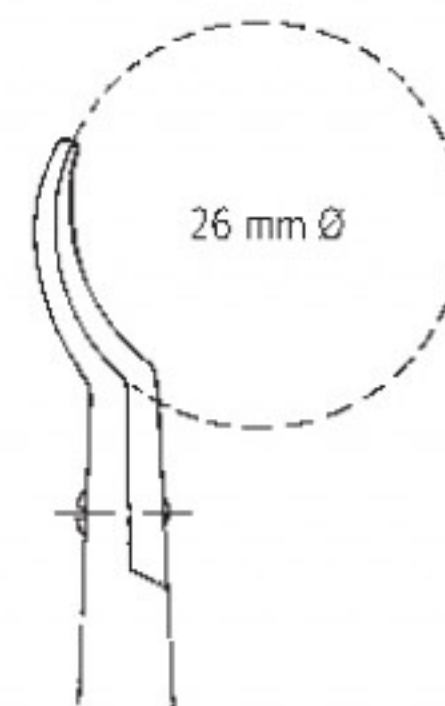

AC SCHEREN SCISSORS TIJERAS CISEAUX FORBICI

Hornhautscheren
 Corneal Scissors
 Pinzas-tijeras para córnea
 Ciseaux corneales
 Forbici per cornea

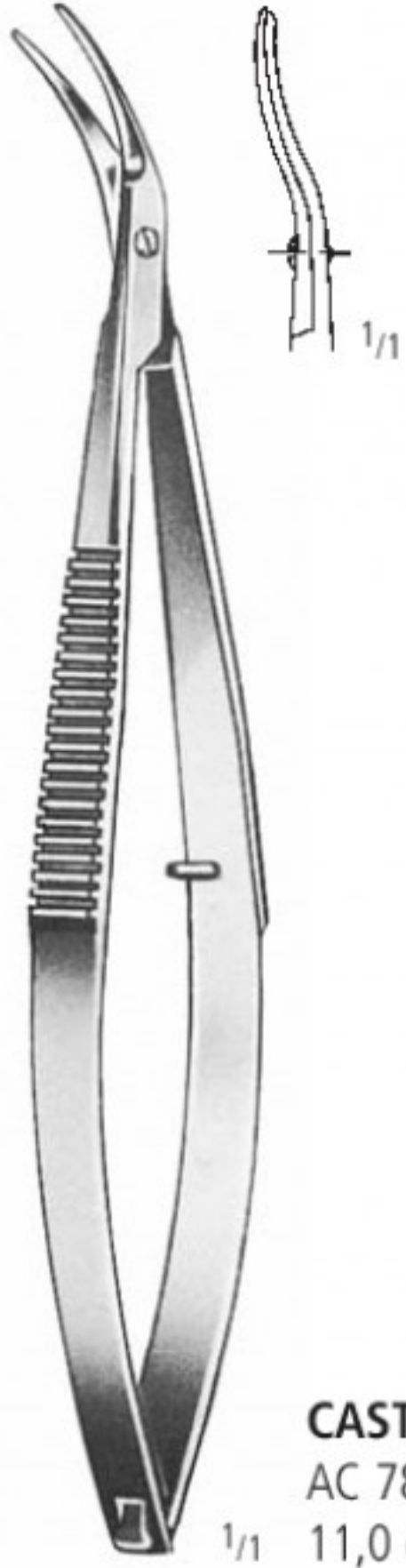

CASTROVIEJO
 AC 786/01
 11,0 cm/4 1/2"

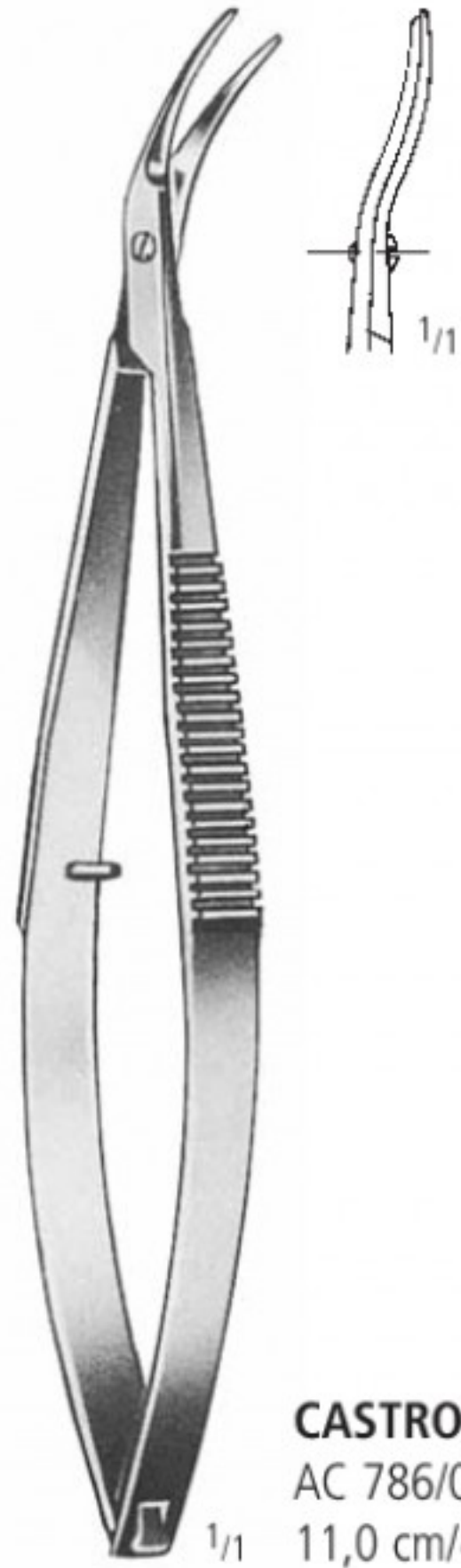

CASTROVIEJO
 AC 786/02
 11,0 cm/4 1/2"



TROUTMAN
 AC 788/01
 10,0 cm/4"

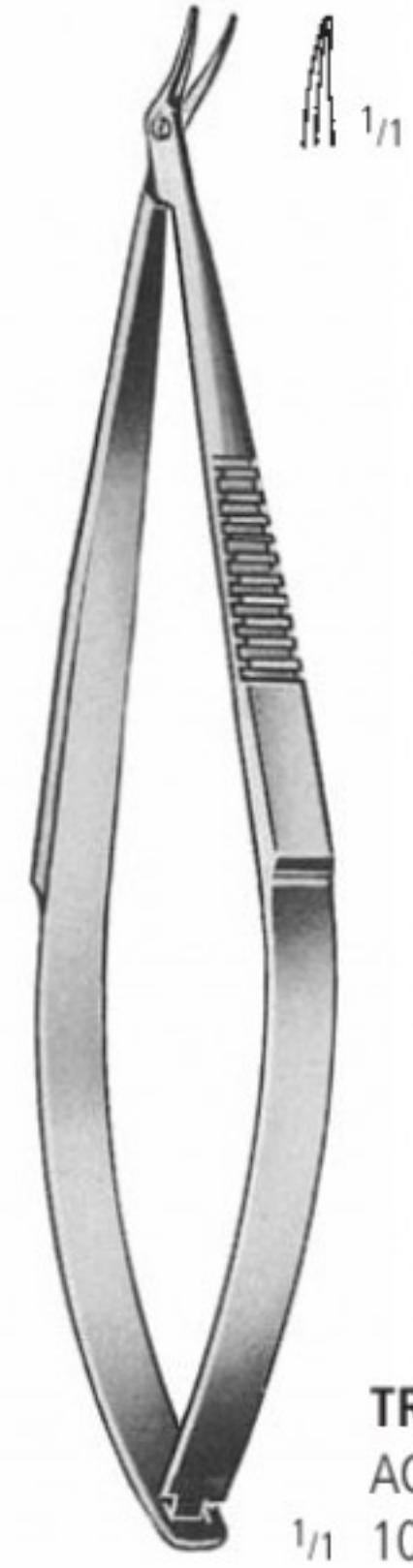

TROUTMAN
 AC 788/02
 10,0 cm/4"

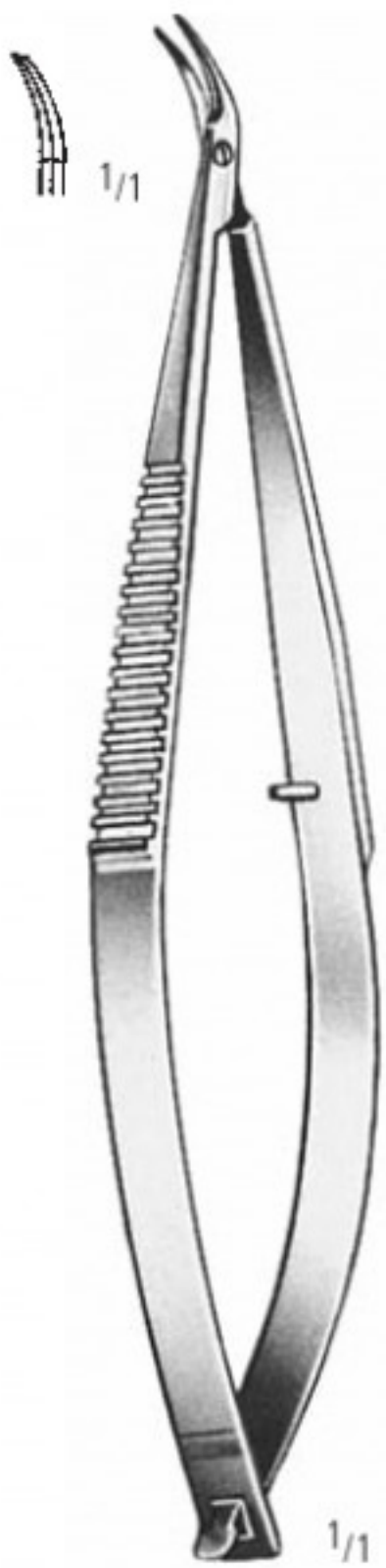

KATZIN
 AC 790/01
 10,0 cm/4"

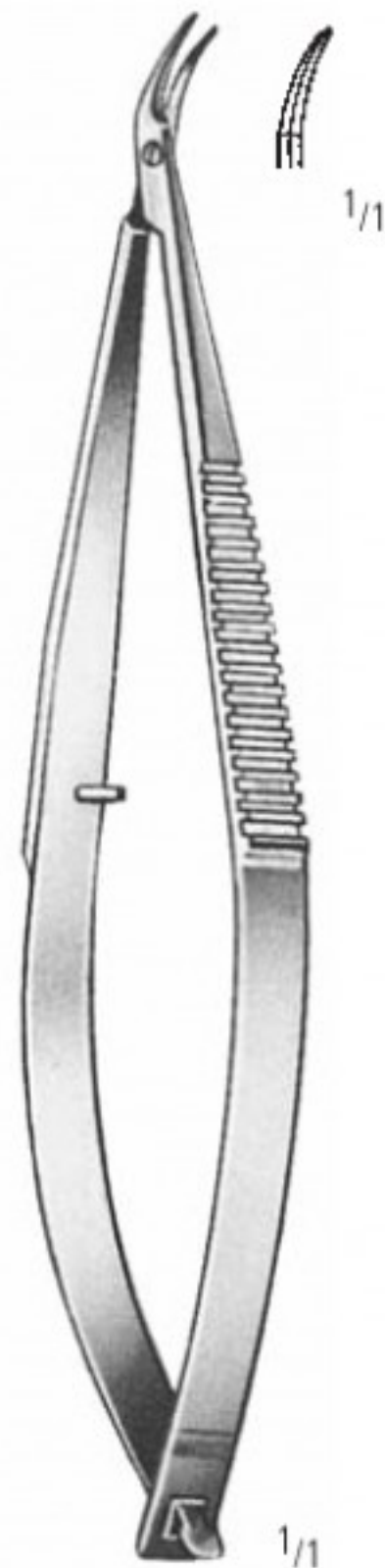

KATZIN
 AC 790/02
 10,0 cm/4"

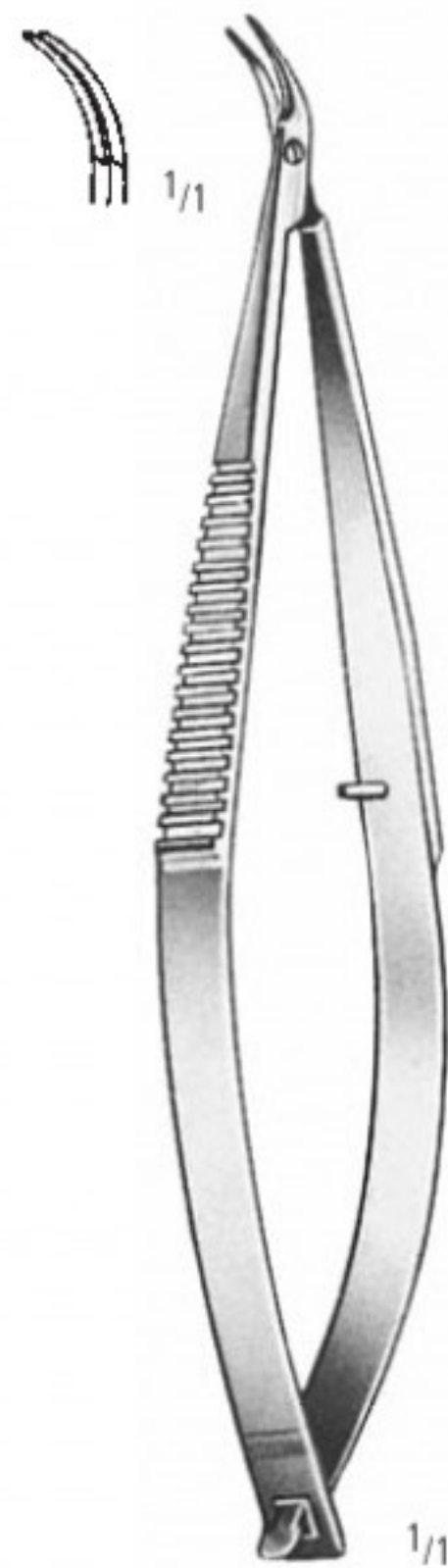

KATZIN
 AC 791/01
 11,0 cm/4 1/2"

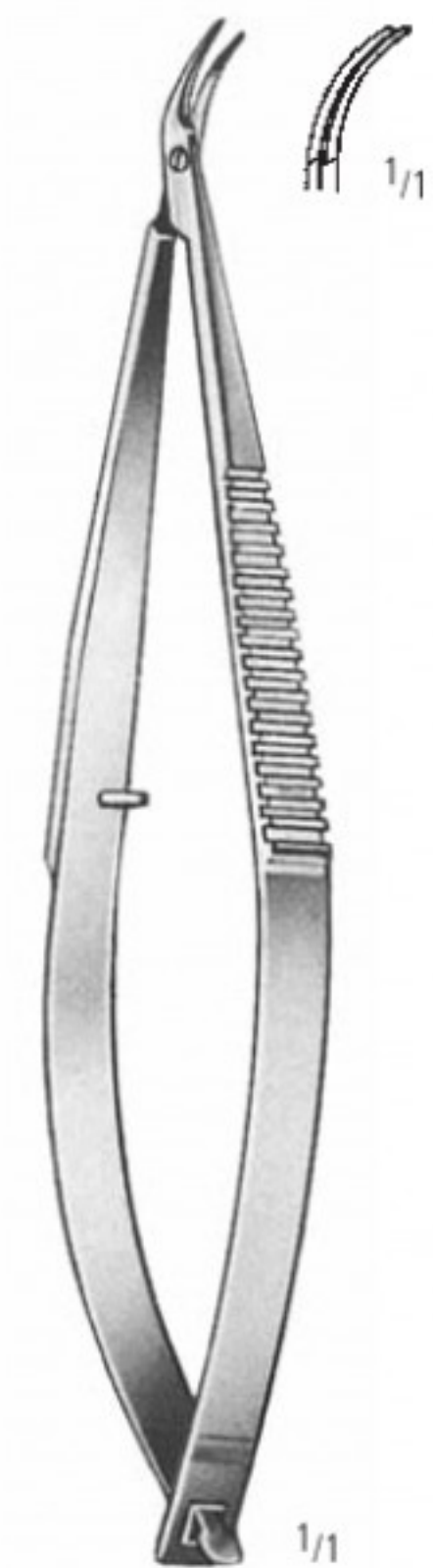

KATZIN
 AC 791/02
 11,0 cm/4 1/2"

SCHEREN SCISSORS TIJERAS CISEAUX FORBICI

Hornhautscheren
 Corneal Scissors
 Pinzas-tijeras para córnea
 Ciseaux corneales
 Forbici per cornea

AA

AB

AC

AD

AE

AK

AR

KA

KM

KO

KP

KYE

XR

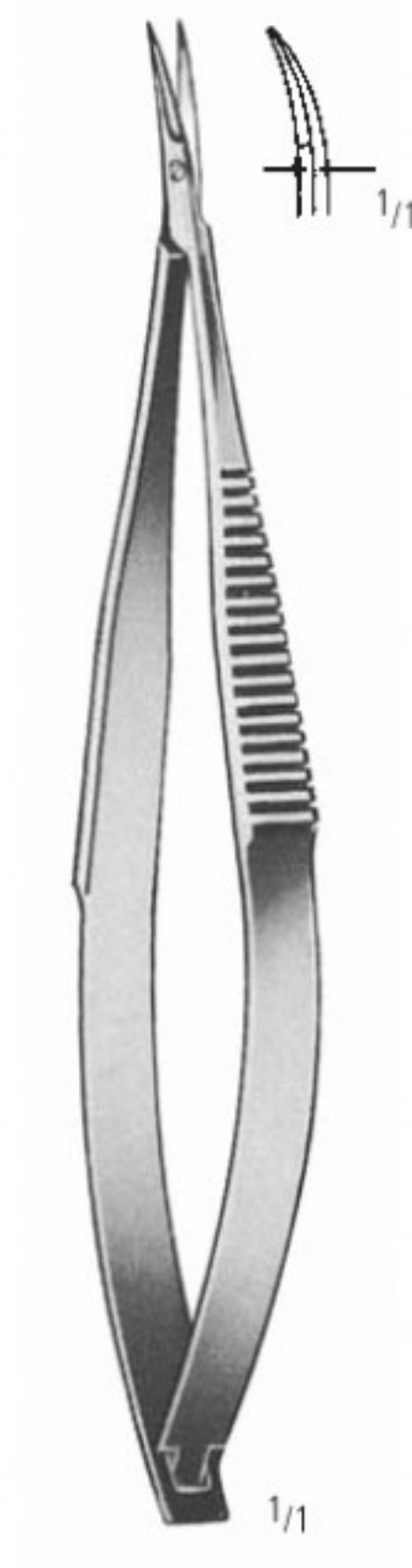
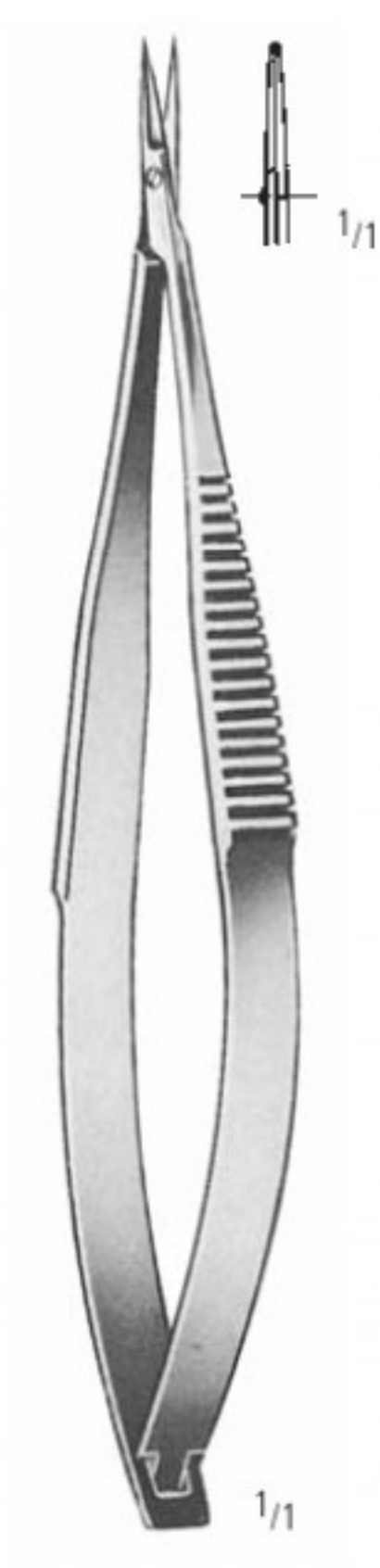
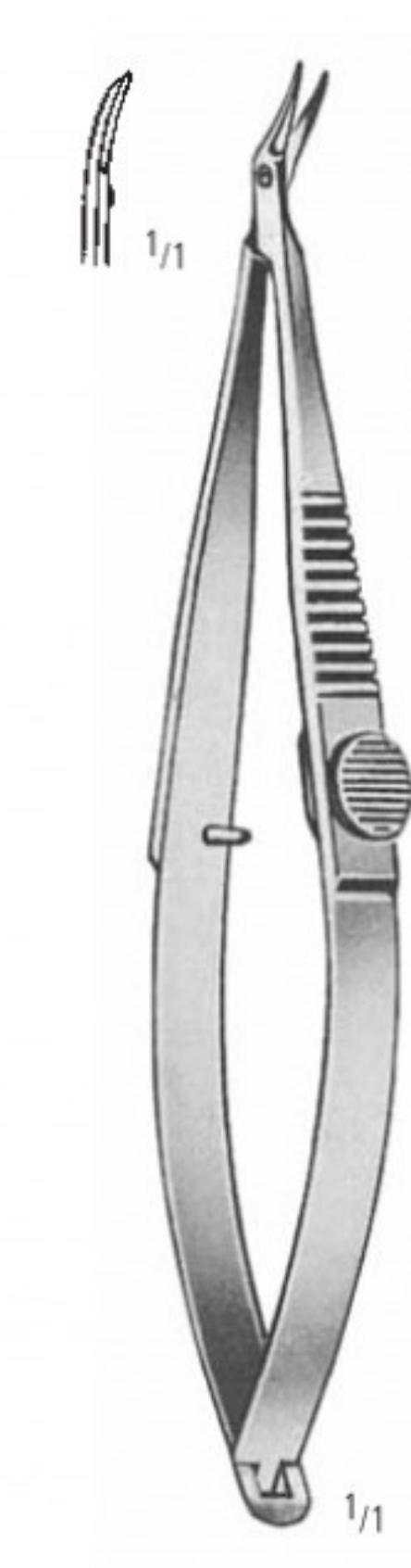
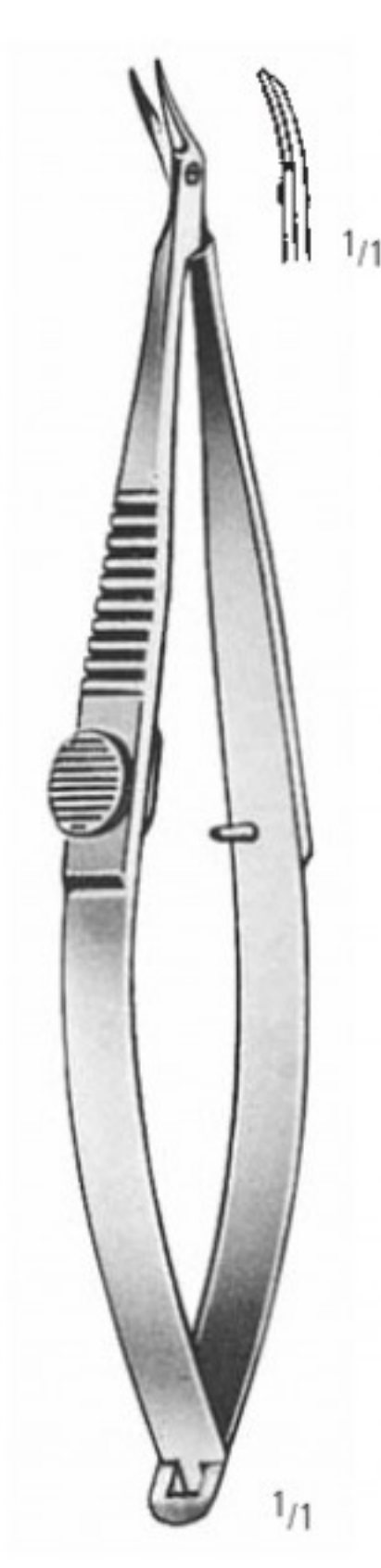

KATZIN-BARRAQUER

AC 792/01
 10,0 cm/4"

AC 792/02
 10,0 cm/4"

AC 793/00
 10,0 cm/4"

AC 793/01
 10,0 cm/4"

AC SCHEREN SCISSORS TIJERAS CISEAUX FORBICI

Hornhautscheren, Mikroscheren
 Corneal Section Scissors, Micro Scissors
 Pinzas-tijeras para córnea, Micro Tijeras
 Pincas ciseaux corneales, Micro-ciseaux
 Forbici per cornea, Micro forbici

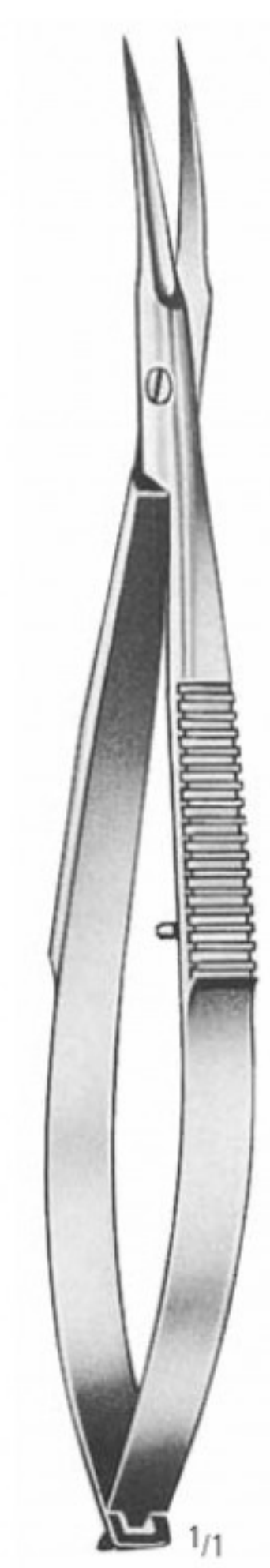

AC 794/12
 12,0 cm/4³/₄"



NOYES
 AC 795/15
 15,0 cm/6"



WESTCOTT
 AC 797/01
 11,5 cm/4¹/₂"

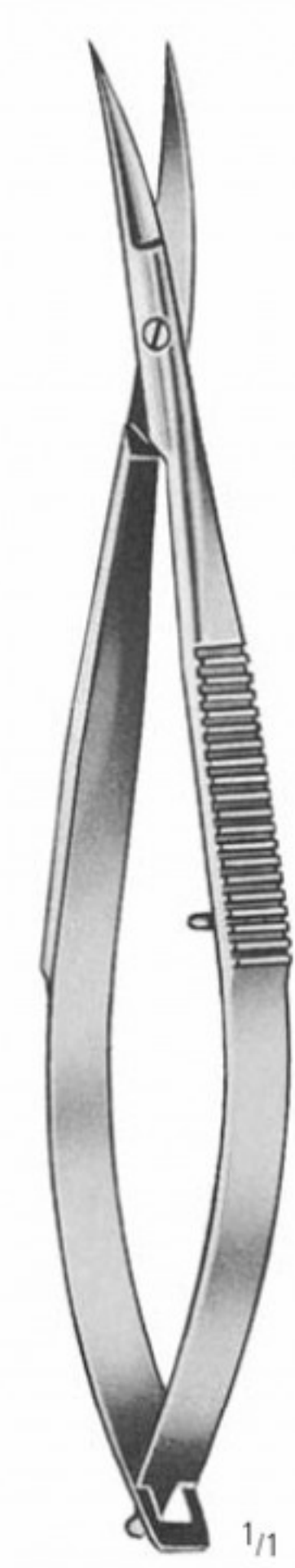

WESTCOTT
 AC 797/02
 11,5 cm/4¹/₂"

SCHEREN SCISSORS TIJERAS CISEAUX FORBICI

Mikroscheren
Micro Scissors
Micro Tijeras
Micro Ciseaux
Micro Forbici

- >> Alle unsere Mikroscheren werden von Fachkräften mit jahrelanger Erfahrung hergestellt. Die Endkontrolle findet unter dem Mikroskop statt. Um Ihnen ein ermüdungsfreies Arbeiten zu ermöglichen, wird dem Federdruck größte Aufmerksamkeit gewidmet.
- >> Bitte wählen Sie unter Rund- oder Flachgriffscheren.

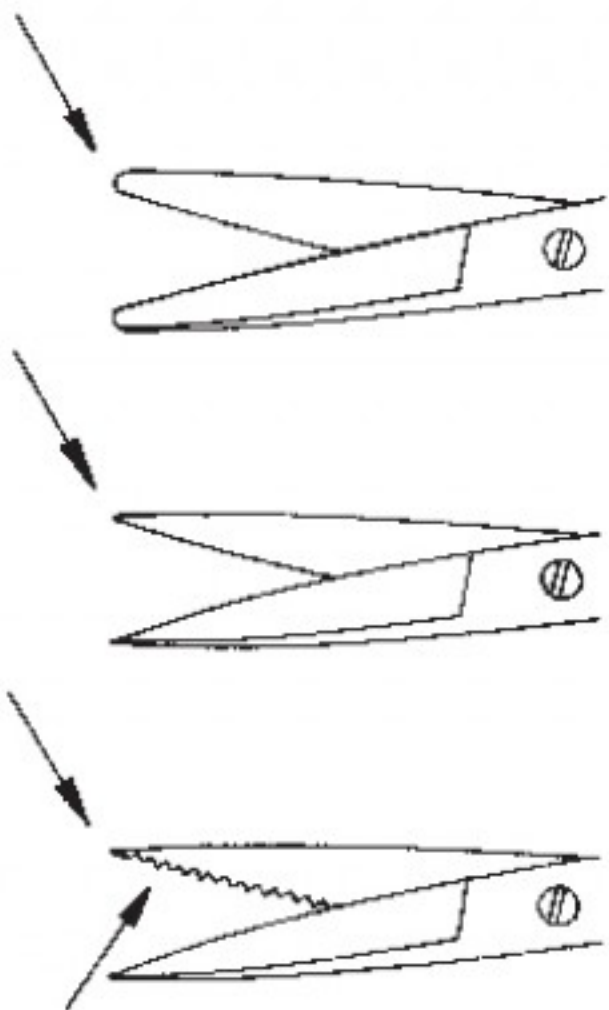

Dissection: **Gebogene Blätter, abgerundete Spitzen** ermöglichen eine gute und sichere Dissektion, ohne Nerven und Blutgefäße zu beschädigen.

Adventitia: **Gerade Blätter, sehr scharfe Spitzen** gewährleisten präzises Anfrischen von Gefäßenden.

Nerve: Ein Blatt ist **fein gezahnt**, um ein Herausgleiten des Nervs zu vermeiden.

- >> All our Micro Scissors are manufactured by skilled craftsmen with many years of experience. Final inspection is carried out under a microscope. Careful attention is paid to the closing pressure of the spring handle, to ensure precise work during surgeries, without fatigue.
- >> Round or flat handle scissors according to your preference.

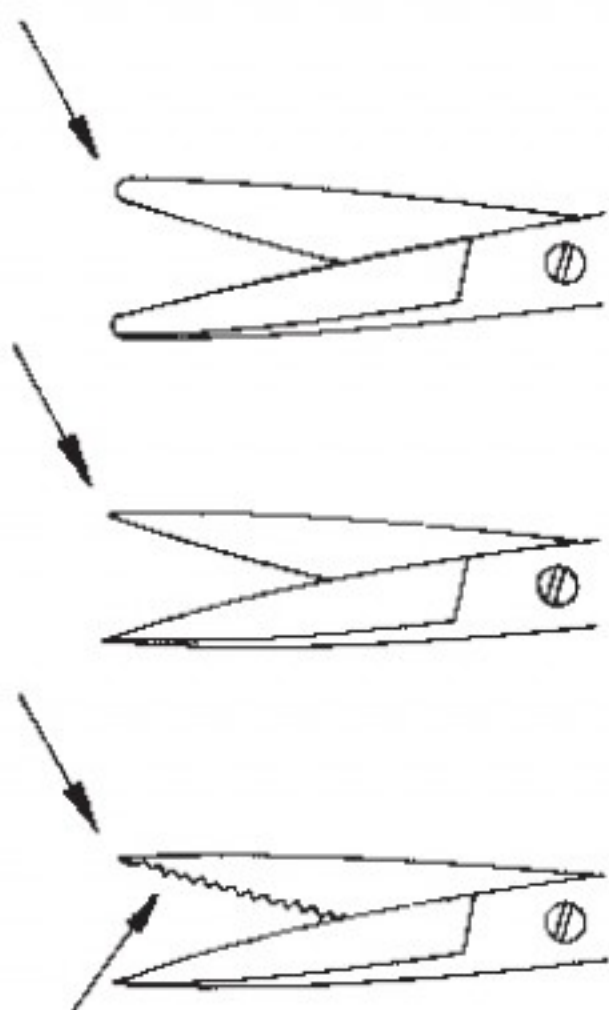

Dissection: **Curved blades, slightly rounded tips** ensure safe dissection without damage to nerves and vessels.

Adventitia: **Straight blades, very sharp tips** for finest trimming of vessel ends.

Nerve: One blade is **fine-toothed** to avoid slipping of the nerve.

AA

AB

AC

AD

AE

AK

AR

KA

KM

KO

KP

KYE

XR

AC SCHEREN SCISSORS TIJERAS CISEAUX FORBICI

Mikroscheren
Micro Scissors
Micro Tijeras
Micro Ciseaux
Micro Forbici

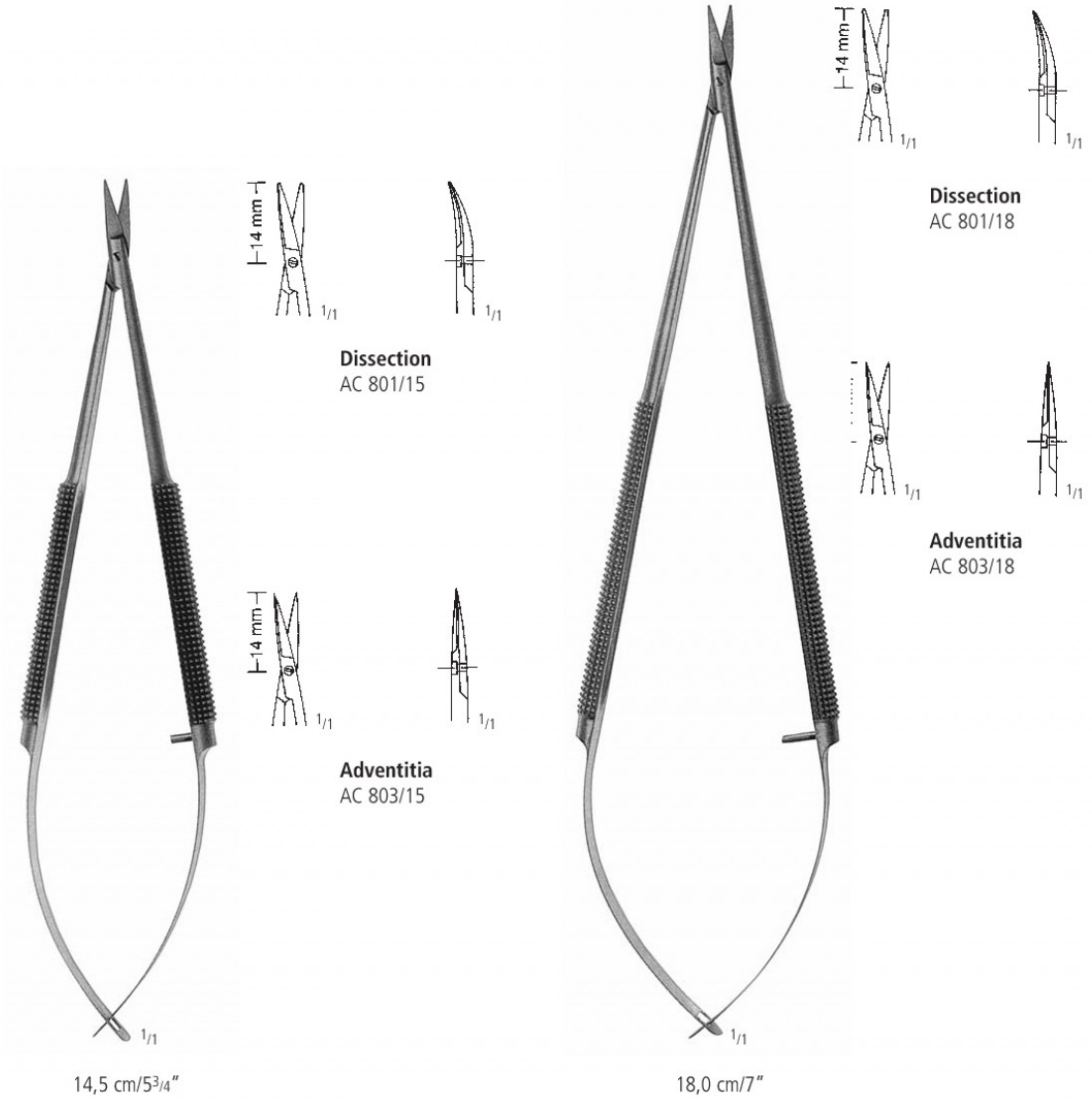

Dissection
AC 801/15

Dissection
AC 801/18

Adventitia
AC 803/15

Adventitia
AC 803/18

14,5 cm/5³/₄"

18,0 cm/7"

SCHEREN SCISSORS TIJERAS CISEAUX FORBICI

Mikroscheren
Micro Scissors
Micro Tijeras
Micro Ciseaux
Micro Forbici

AA

AB

AC

AD

AE

AK

AR

KA

KM

KO

KP

KYE

XR



AC 807/14
14,5 cm/5³/₄"



AC 812/18
18,0 cm/7"



AC 817/18
18,0 cm/7"

AC SCHEREN SCISSORS TIJERAS CISEAUX FORBICI

Mikroscheren
Micro Scissors
Micro Tijeras
Micro Ciseaux
Micro Forbici



11,0 cm/4¹/₃"

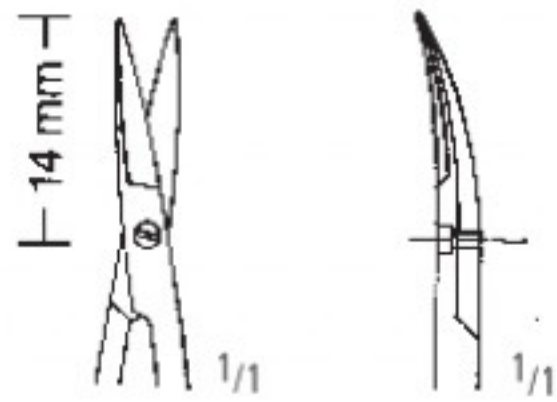

Dissection
AC 821/11

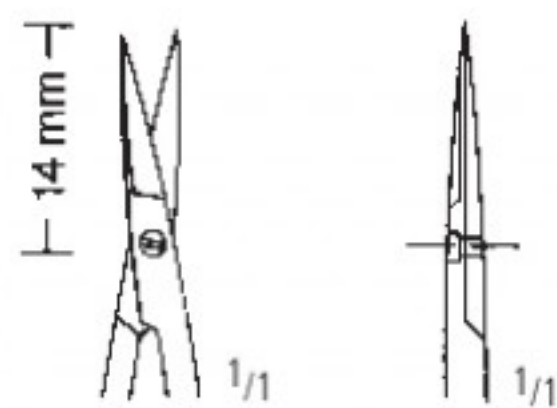

Adventitia
AC 830/11

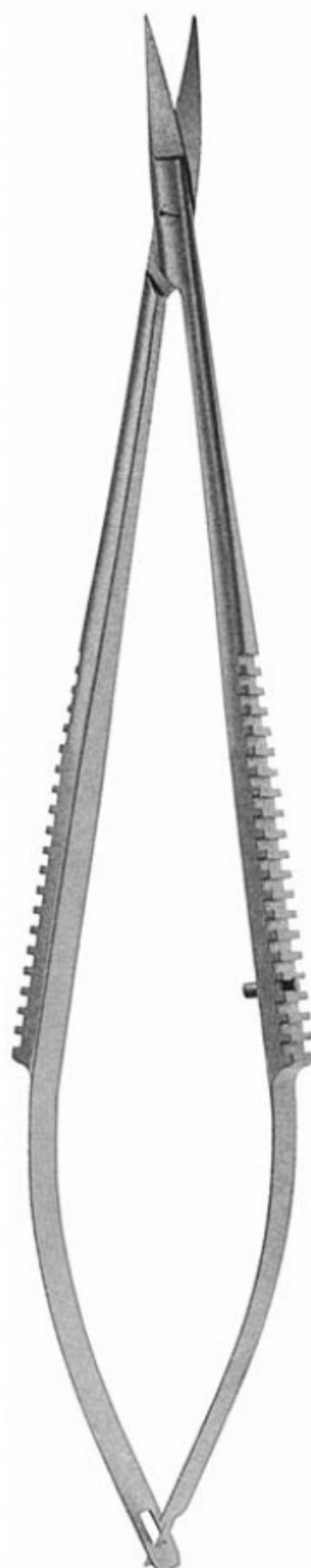

15,0 cm/6"

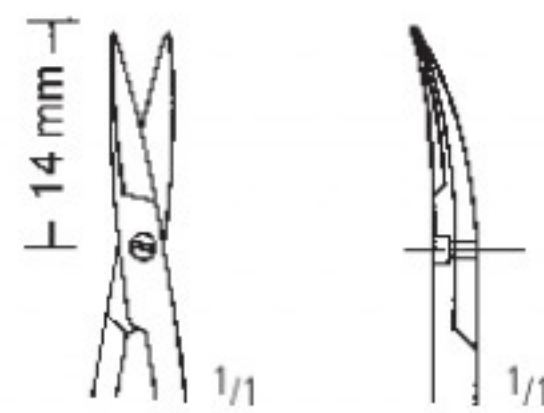

Dissection
AC 823/15

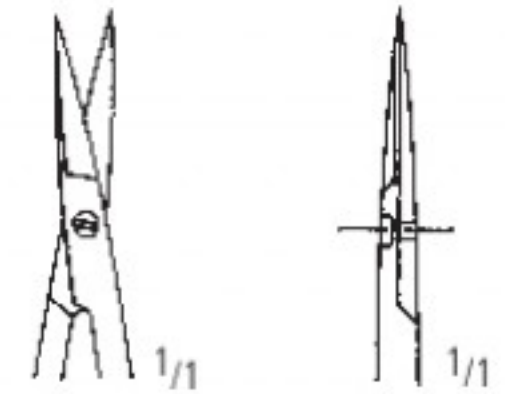

Adventitia
AC 832/15

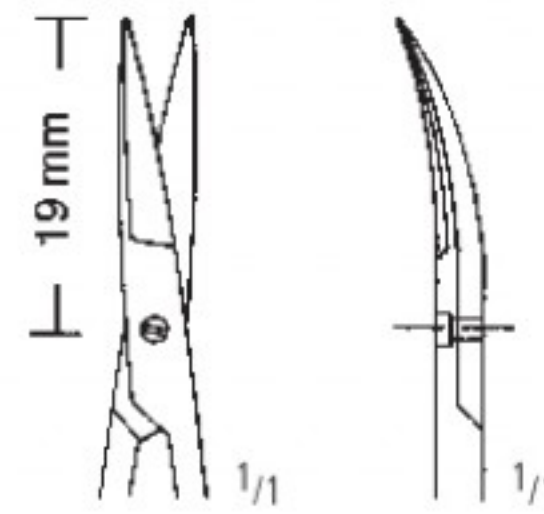

Dissection
AC 825/15

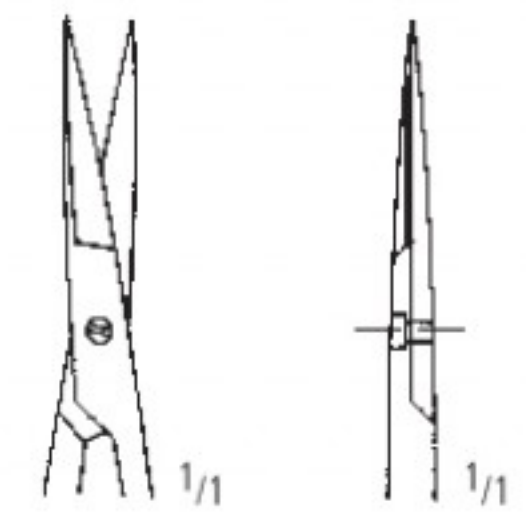

Adventitia
AC 834/15

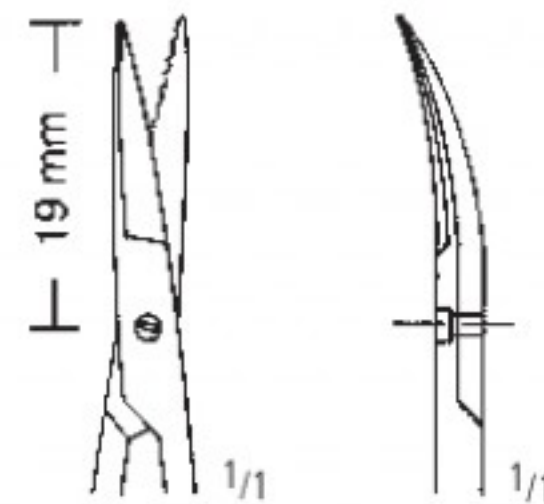

Dissection
AC 827/15

>> Nerve >>

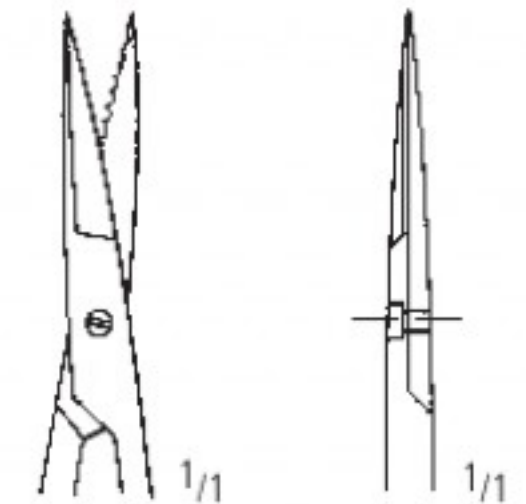

Adventitia
AC 836/15

SCHEREN SCISSORS TIJERAS CISEAUX FORBICI

Mikroscheren
Micro Scissors
Micro Tijeras
Micro Ciseaux
Micro Forbici

AA

AB

AC

AD

AE

AK

AR

KA

KM

KO

KP

KYE

XR

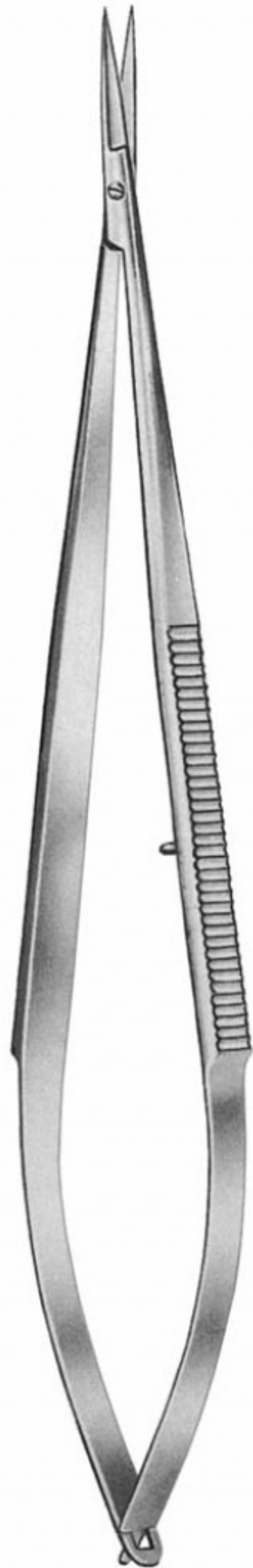

18,5 cm/7¹/₃"

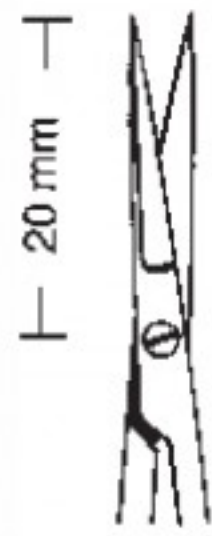

AC 850/19



AC 851/19



16,0 cm/6¹/₄"
20,0 cm/8"
22,5 cm/9"



AC 860/16
AC 860/20
AC 860/22



AC 861/16
AC 861/20
AC 861/22



AC 862/16
AC 862/20
AC 862/22



AC 863/16
AC 863/20
AC 863/22



AC 864/16
AC 864/20
AC 864/22



AC 865/16
AC 865/20
AC 865/22

AC SCHEREN SCISSORS TIJERAS CISEAUX FORBICI

Mikroscheren
Micro Scissors
Micro Tijeras
Micro Ciseaux
Micro Forbici



18,0 cm/7"
1/2

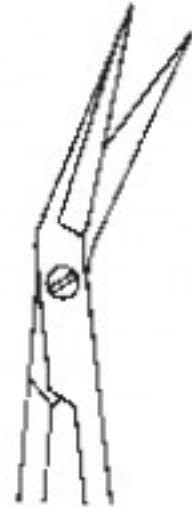

AC 870/01
25°

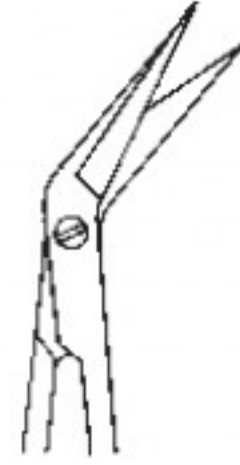

AC 870/02
45°

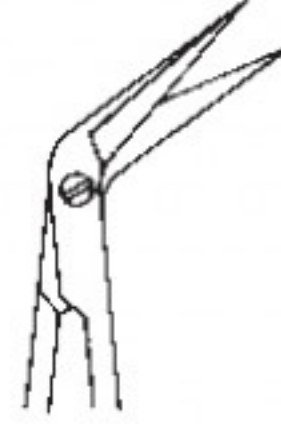

AC 870/03
60°

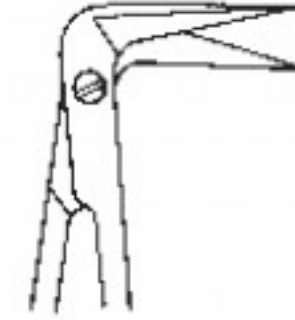

AC 870/04
90°

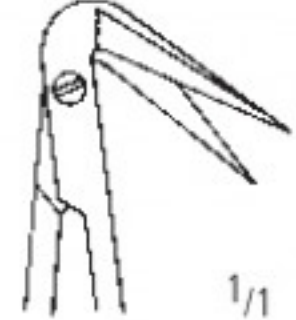

AC 870/05
125°
1/1

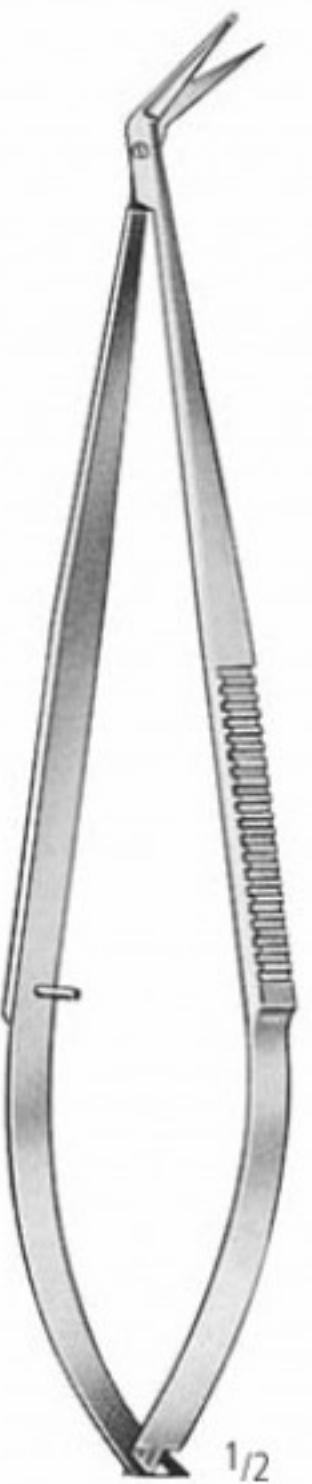

18,0 cm/7"
1/2



AC 871/01
25°

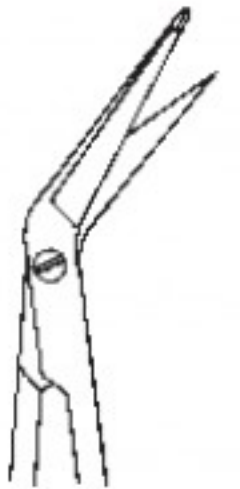

AC 871/02
45°

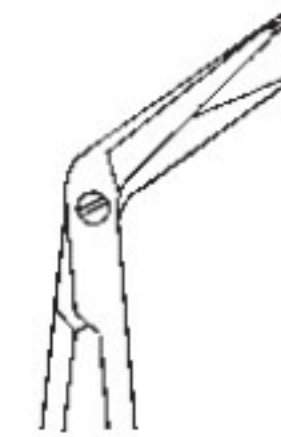

AC 871/03
60°



AC 871/04
90°

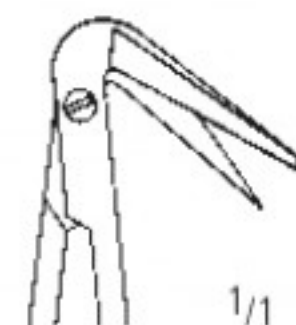

AC 871/05
125°
1/1

SKALPELLE
SCALPELS
BISTURIES
BISTOURIS
BISTURI

AD

nopa[®] instruments





SKALPELLE SCALPELS BISTURIES BISTOURIS BISTURI

Skalpellgriffe
 Scalpel Handles
 Mangos de bisturías
 Manches pour bistouris
 Manici per bisturi

AA

AB

AC

AD

AE

AK

AR

KA

KM

KO

KP

KYE

XR

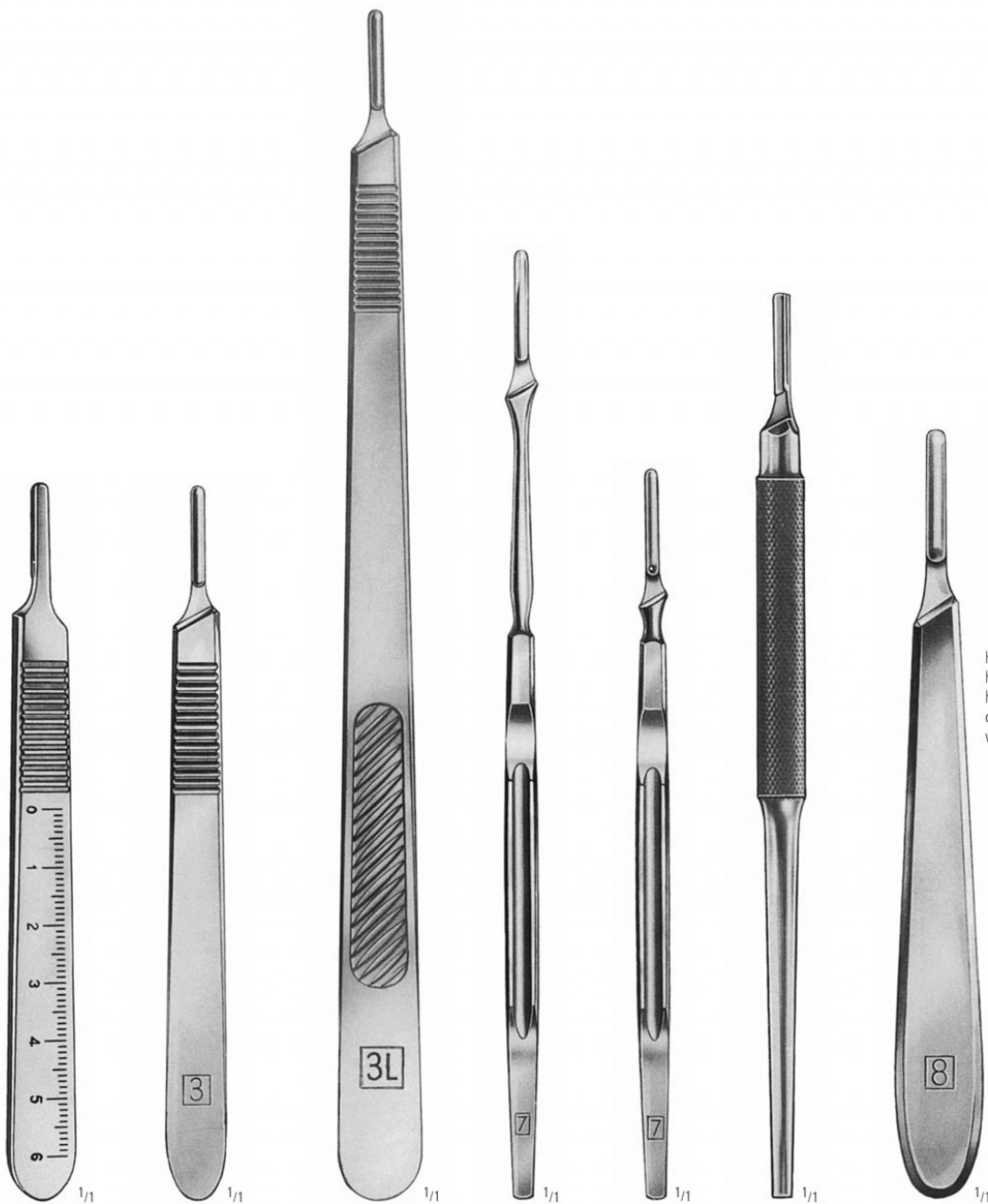

hohl
 hollow
 hueco
 creux
 vuoto

AD 009/03
 No. 3

AD 010/03
 No. 3

AD 020/13
 No. 3L

AD 025/07
 No. 7

AD 027/07
 No. 7K

AD 030/16

COLLIN
 AD 040/08
 No. 8

Skalpellgriffe, Skalpellklingen
 Scalpel Handles, Scalpel Blades
 Mangos de bisturías, Hojas de busturías
 Manches pour bistouris, Lames de bistouris
 Manici per bisturi, Lame per bisturi

MINI

Verpackungseinheit 10 St.
 packing unit 10 pcs.
 unidad de venta 10 piezas
 unité à 10 pièce
 unità di vendita 10 pezzi



Fig. 65
 AD 065/65

steril
 sterile
 estériles
 stériles
 sterili



Fig. 67
 AD 065/67



AD 065/10

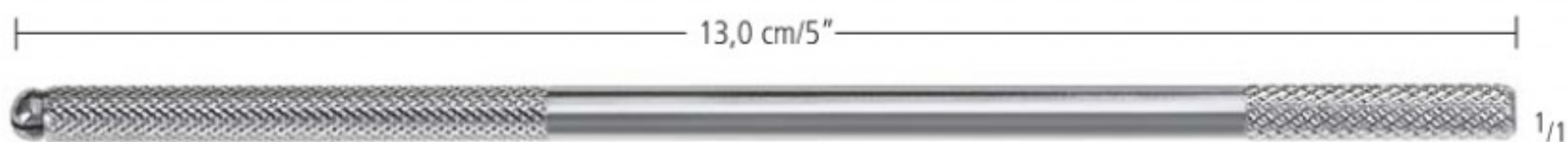

AD 065/13

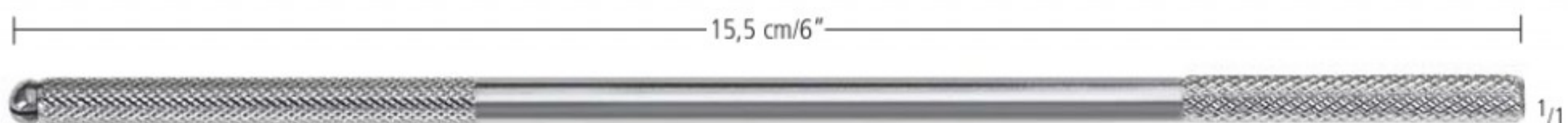

AD 065/15

SKALPELLE SCALPELS BISTURIES BISTOURIS BISTURI

Skalpellklingen
 Scalpel Blades
 Hojas de bisturías
 Lames pour bistouris
 Lame per bisturi

passend für die Griffe
 for handles
 para los mangos
 pour les manches
 per i manici

AD 009/03
 AD 010/03
 AD 020/13
 AD 025/07
 AD 027/07
 AD 030/16
 AD 040/08



Fig.10
 AD 075/10



Fig.11
 AD 075/11



Fig.15
 AD 075/15



Fig.15c
 AD 076/15

steril
 sterile
 estériles
 stériles
 sterili



AA

AB

AC

AD

AE

AK

AR

KA

KM

KO

KP

KYE

XR

AD SKALPELLE SCALPELS BISTURIES BISTOURIS BISTURI

Rasierklngen, Klingenbrecher
 Razor Blades, Blade Breakers
 Hojas de afeitarr, Pinzas para romper hojas
 Lames de rasoir, Pincettes pour casser les lames
 Lamette da barba, Pinze per rompere la lamette

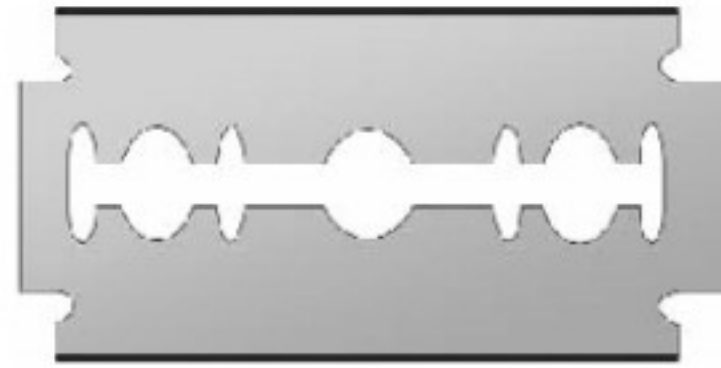

RASIERKLINGEN, VERPACKUNGSEINHEIT 10 STCK
 RAZOR BLADES, PACKING UNIT 10 PIECES
 HOJAS DE AFEITAR, UNIDAD DE VENTA 10 PZ
 LAMES DE RASOIR, UNITÉ À 10 PIÈCES
 LAMETTE DA BARBA, UNITÀ DI VENDITA 10 PZ

AD 540/00



TROUTMAN-CHRIS
 AD 550/09
 Ø 5,5 mm
 9,0 cm/3¹/₂"



TROUTMAN-CHRIS
 AD 551/09
 Ø 5,5 mm
 9,0 cm/3¹/₂"



AD 552/11
 11,0 cm/4¹/₃"



CASTROVIEJO
 AD 554/13
 Ø 8 mm
 13,0 cm/5"

NAHT
SUTURE
SUTURA
SUTURE
SUTURA

AE

nopa[®] instruments



Nadelhalter, Nadelhalter mit Hartmetalleinsätzen
 Needle Holders, Needle Holders with Tungsten Carbide Inserts
 Porta-agujas, Porta-agujas con bocas de carburo de Tungsteno
 Porte-aiguilles, Porte-aiguilles à mors en carbure de tungstène
 Portaghi, Portaghi con placche di carburo di tungsteno



DERF
 AE 050/12
 12,5 cm/4³/₄"

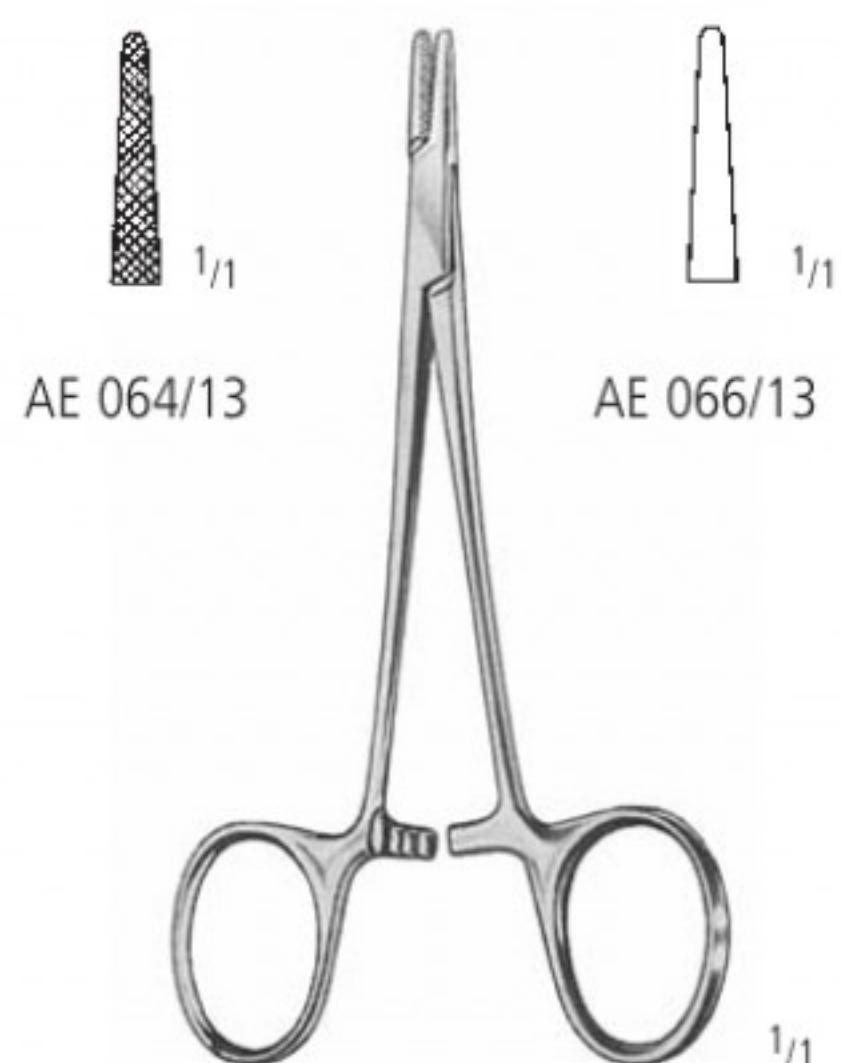

HALSEY
 13,0 cm/5"

nopa
TUC[®]



RYDER/FRENCH-EYE
 AE 430/13
 13,0 cm/5"



DERF
 AE 450/12
 12,5 cm/4³/₄"

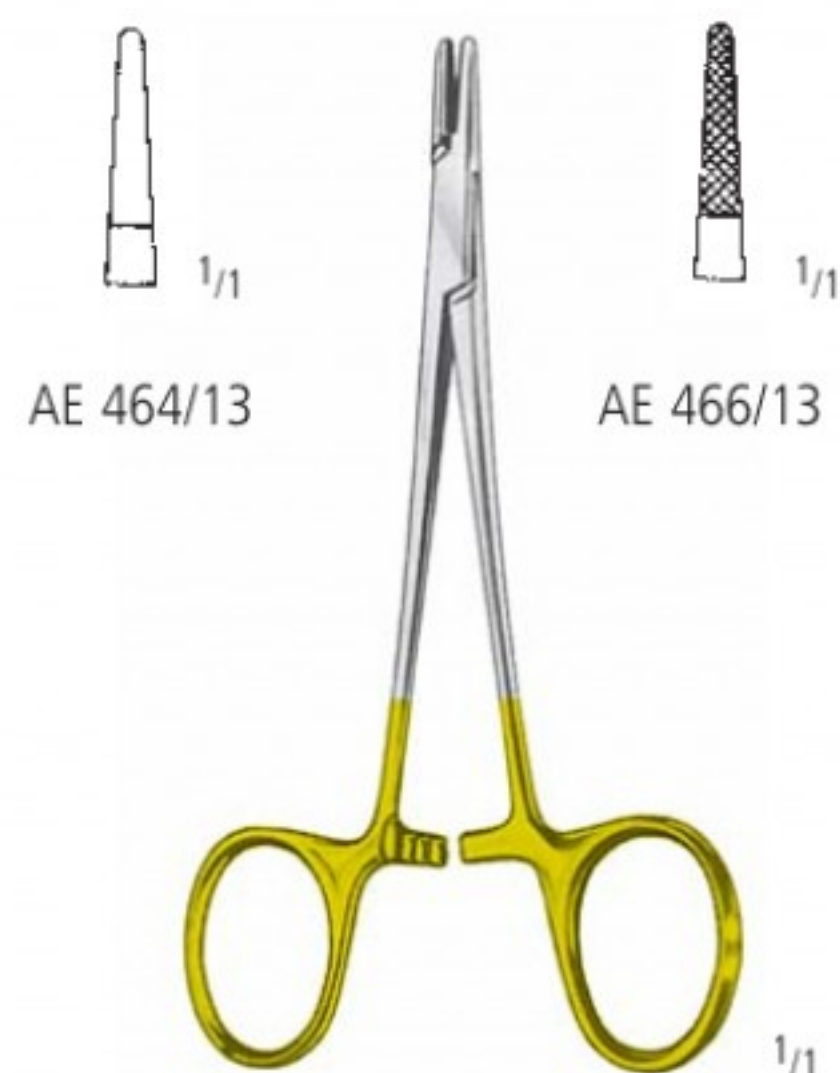

HALSEY
 13,0 cm/5"

NAHT SUTURE SUTURA SUTURE SUTURA

Nadelhalter mit Hartmetalleinsätzen
 Needle Holders with Tungsten Carbide Inserts
 Porta-agujas con bocas de carburo de tungsteno
 Porte-aiguilles à mors en carbure de tungstène
 Portaghi con placche di carburo di tungsteno

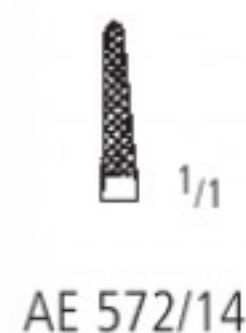
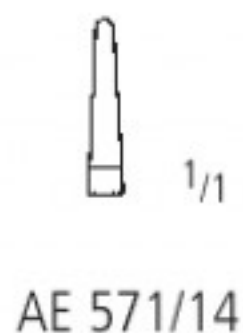
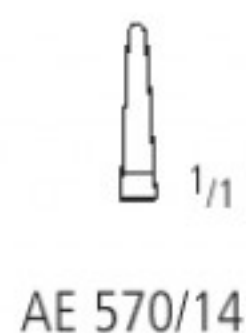

CASTROVIEJO
 14,0 cm/5 1/2"

CASTROVIEJO
 14,0 cm/5 1/2"

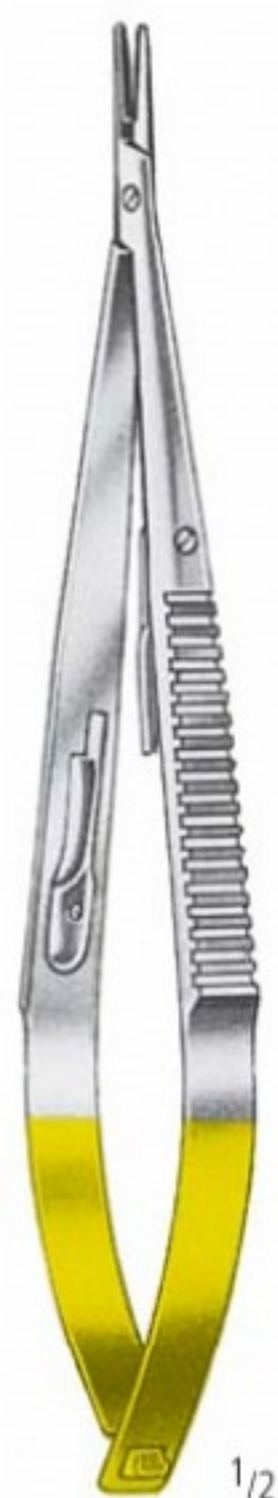
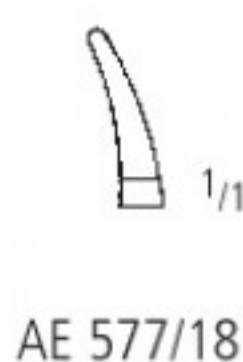
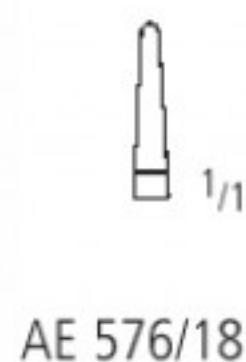
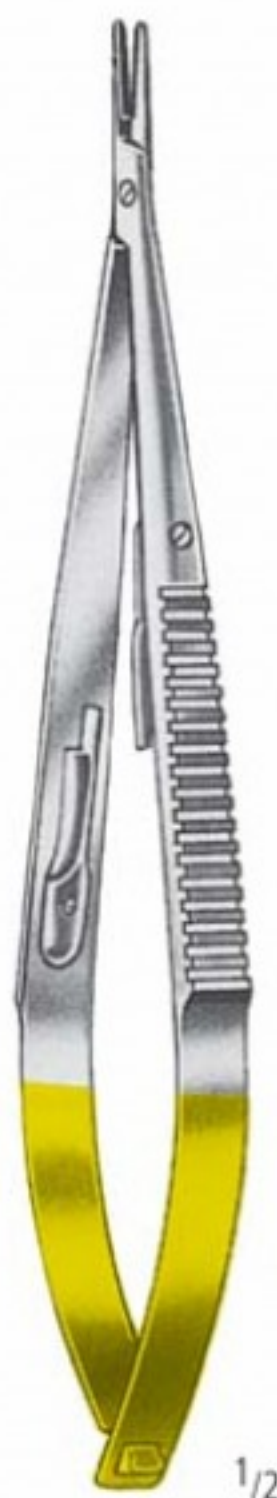

18,0 cm/7"

18,0 cm/7"

AA

AB

AC

AD

AE

AK

AR

KA

KM

KO

KP

KYE

XR

AE NAHT SUTURE SUTURA SUTURE SUTURA

Mikro-Nadelhalter mit Hartmetalleinsätzen
 Micro-Needle Holders with Tungsten Carbide Inserts
 Micro-porta-agujas con bocas de carburo de Tungsteno
 Micro-porte-aiguilles à mors en carbure de tungstène
 Micro-portaghi con placche di carburo di tungsteno

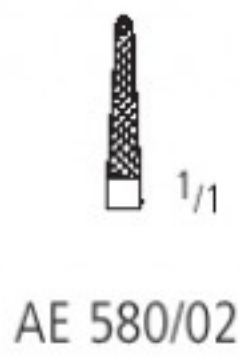
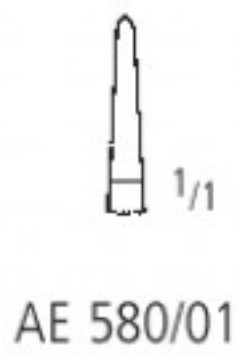

JACOBSON
21,0 cm/8¹/₄"



AE 582/16
16,0 cm/6¹/₄"



AE 582/18
18,0 cm/7"



AE 582/20
20,0 cm/8"



AE 582/23
23,0 cm/9"



AE 582/26
26,0 cm/10¹/₄"

DIETHRICH



KALT
AE 584/14
13,5 cm/5¹/₄"



CASTROVIEJO
AE 586/13
13,0 cm/5¹/₄"



POTTS-SMITH
AE 588/22
22,0 cm/8³/₄"

NAHT SUTURE SUTURA SUTURE SUTURA

Mikro-Nadelhalter mit Rundgriff
 Micro-Needle-Holders with pen-type handle
 Micro-porta-agujas con mango redondo
 Micro-porte-aiguilles à manches rondes
 Micro-portaghi con manici rotondi

AA
 AB
 AC
 AD
AE
 AK
 AR
 KA
 KM
 KO
 KP
 KYE
 XR

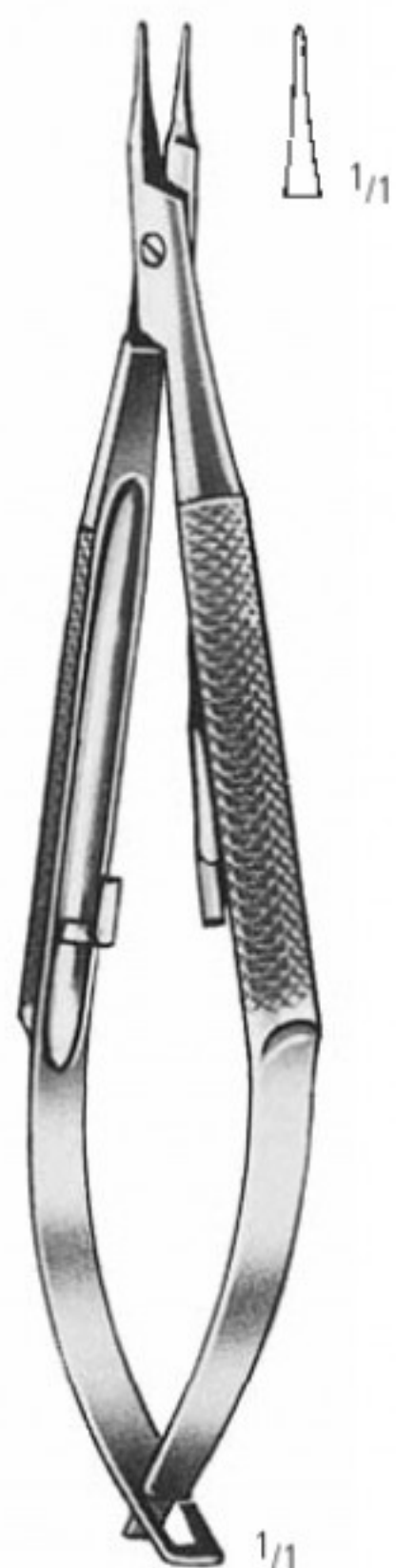

**BARRAQUER-
TROUTMAN**
 AE 600/10
 10,0 cm/4"

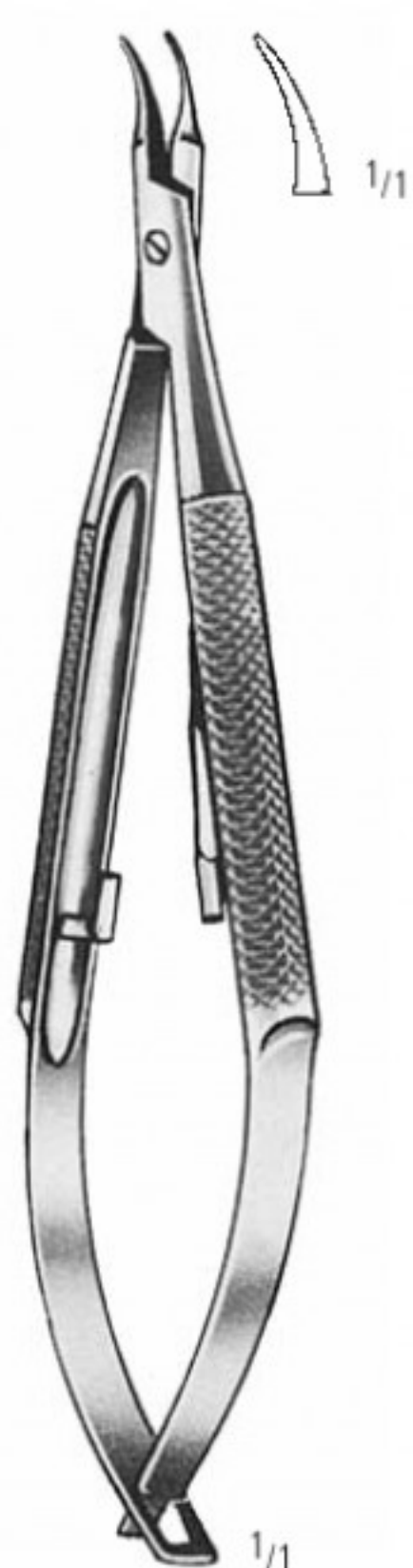

**BARRAQUER-
TROUTMAN**
 AE 601/10
 10,0 cm/4"

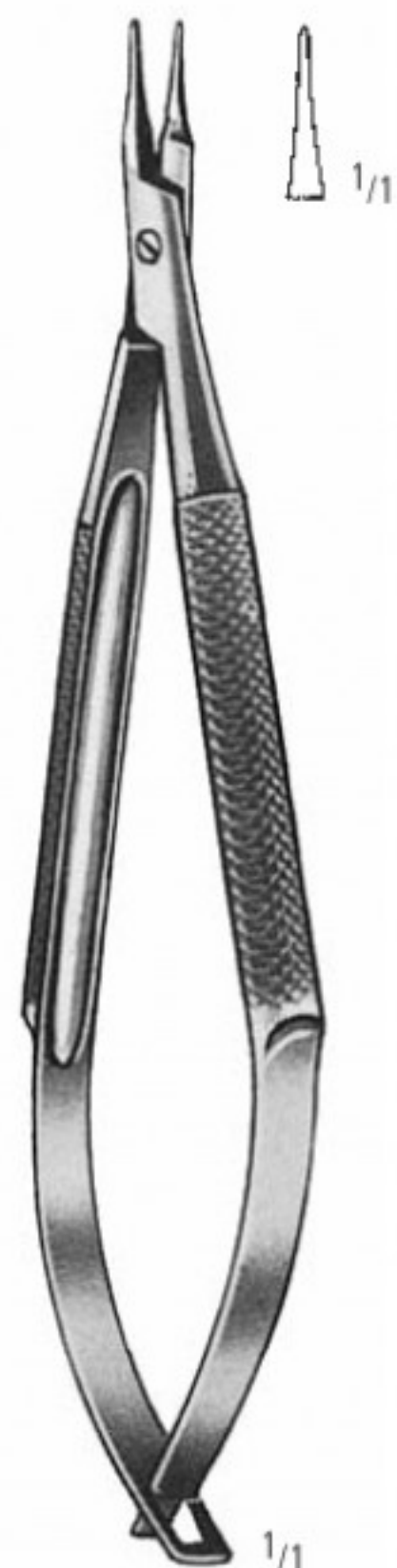

**BARRAQUER-
TROUTMAN**
 AE 602/10
 10,0 cm/4"

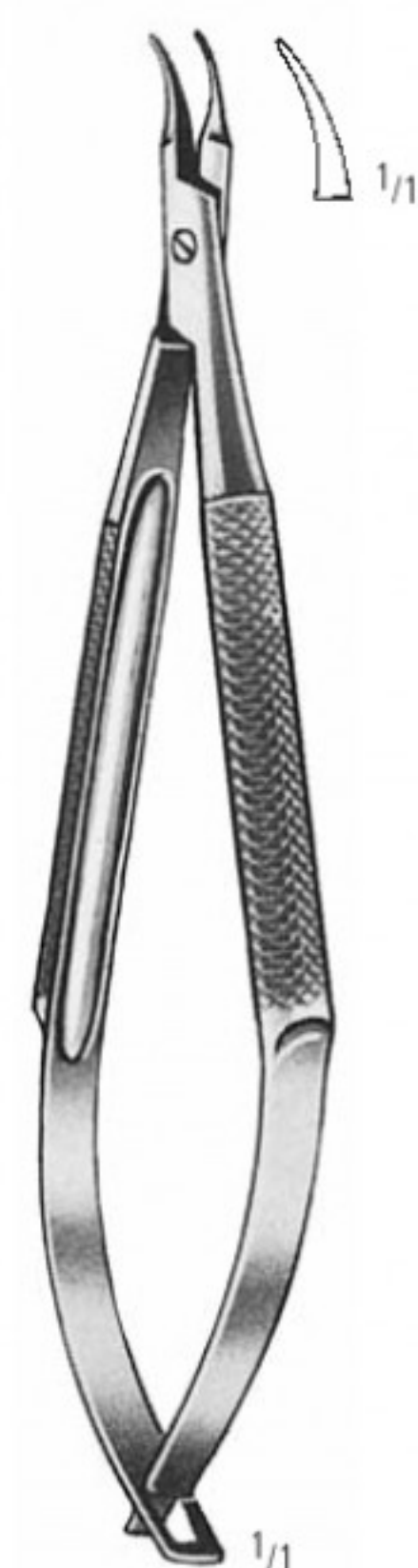

**BARRAQUER-
TROUTMAN**
 AE 603/10
 10,0 cm/4"



BARRAQUER
 AE 605/11
 11,0 cm/4¹/₄"



BARRAQUER
 AE 605/13
 13,0 cm/5"



BARRAQUER
 AE 605/14
 14,0 cm/5¹/₂"



BARRAQUER
 AE 606/14
 14,0 cm/5¹/₂"



BARRAQUER
 AE 607/14
 14,0 cm/5¹/₂"

AE NAHT SUTURE SUTURA SUTURE SUTURA

Mikro-Nadelhalter mit Rundgriff
 Micro-Needle-Holders with pen-type handle
 Micro-porta-agujas con mango redondo
 Micro-porte-aiguilles à manches rondes
 Micro-portaghi con manici rotondi



TROUTMAN
 AE 609/01
 12,0 cm/4³/₄"



TROUTMAN
 AE 609/02
 12,0 cm/4³/₄"



AE 610/15

AE 611/15



AE 612/15

AE 613/15

REILL
 15,0 cm/6"

REILL
 15,0 cm/6"

NAHT SUTURE SUTURA SUTURE SUTURA

Mikro-Nadelhalter
 Micro-Needle-Holders
 Micro-porta-agujas
 Micro-porte-aiguilles
 Micro-portaghi

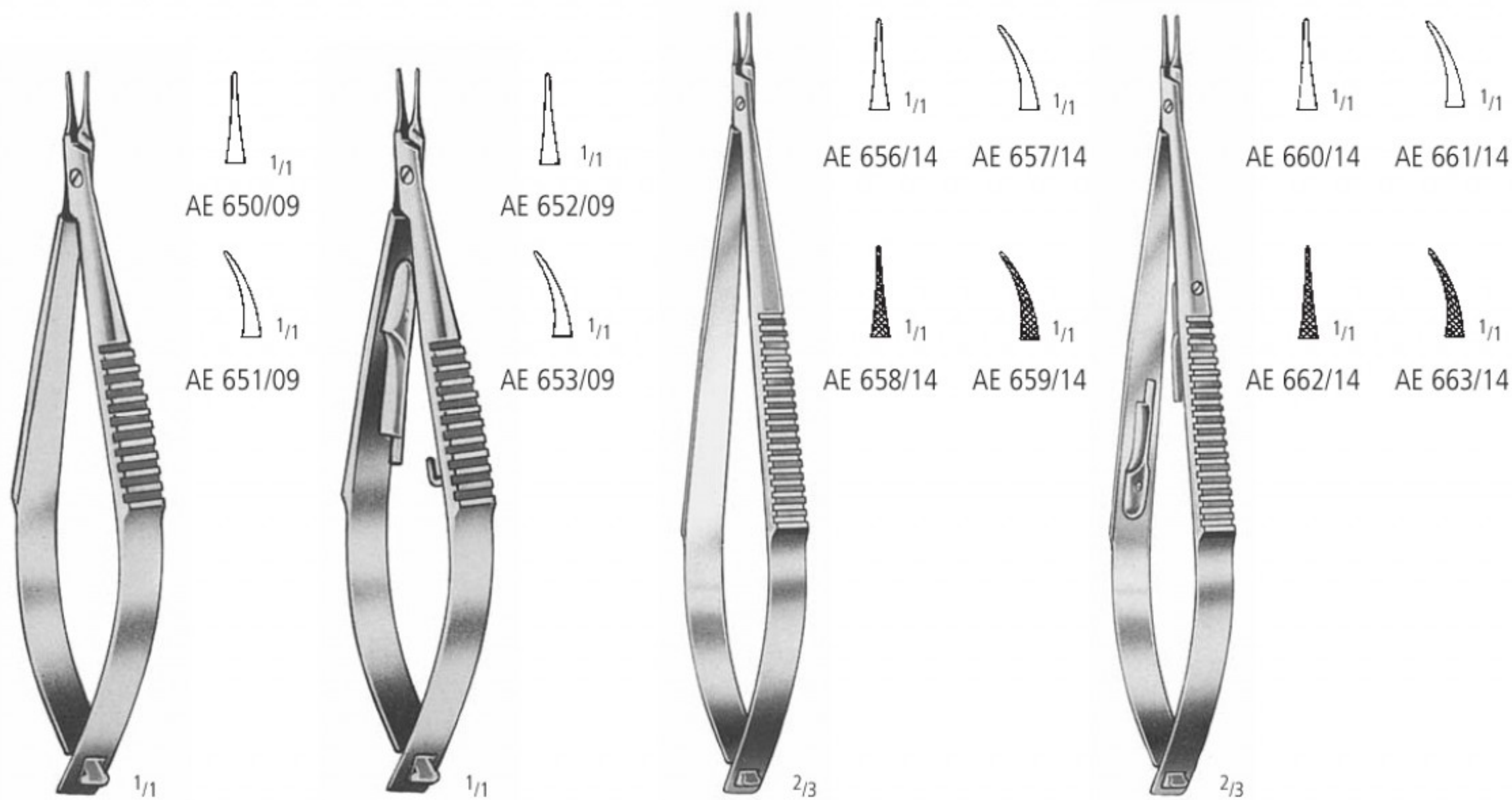

CASTROVIEJO
 9,0 cm/3 1/2"

CASTROVIEJO
 9,0 cm/3 1/2"

CASTROVIEJO
 14,0 cm/5 1/2"

CASTROVIEJO
 14,0 cm/5 1/2"

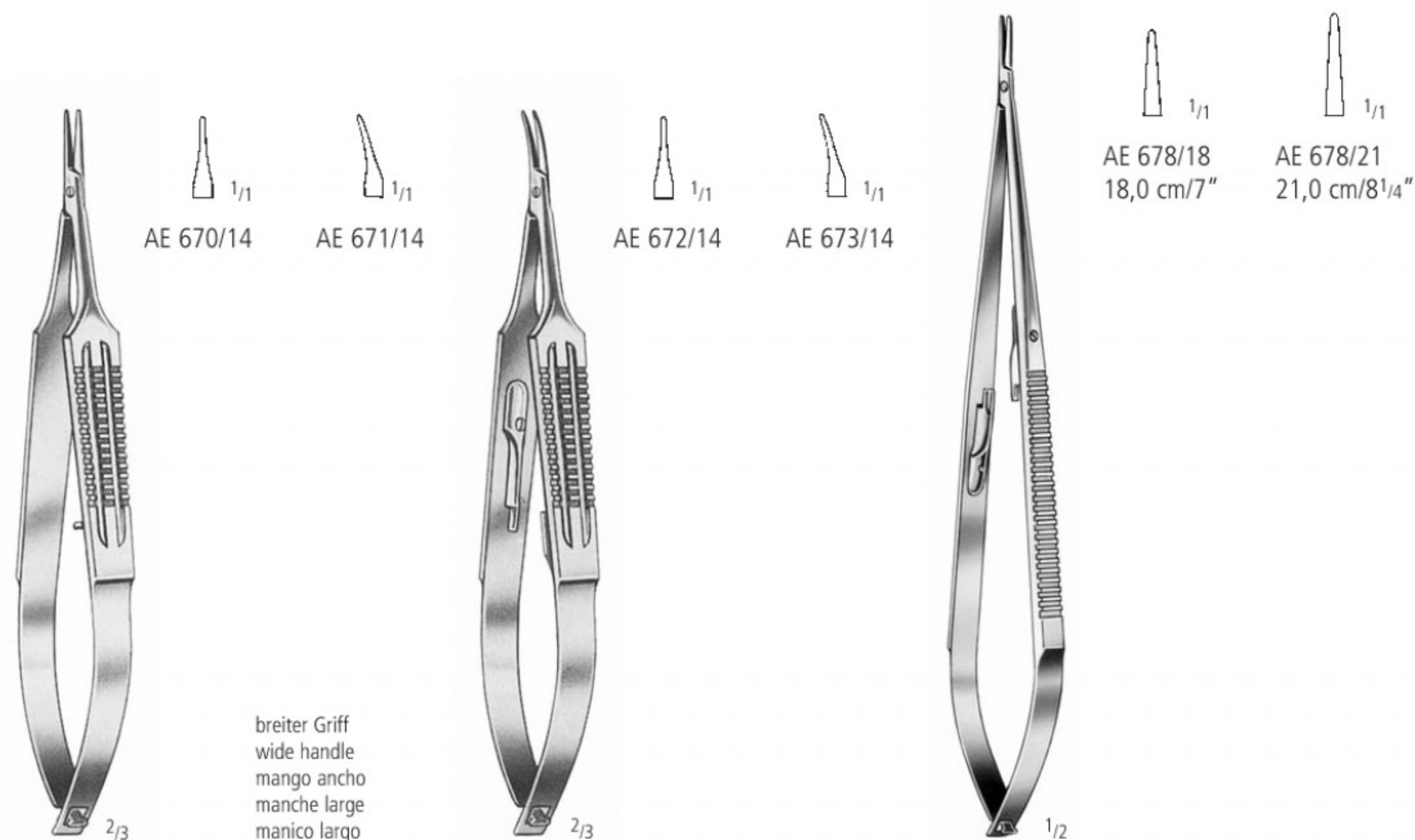

CASTROVIEJO
 14,0 cm/5 1/2"

CASTROVIEJO
 14,0 cm/5 1/2"

JACOBSON

breiter Griff
 wide handle
 mango ancho
 manche large
 manico largo

AA

AB

AC

AD

AE

AK

AR

KA

KM

KO

KP

KYE

XR

AE NAHT SUTURE SUTURA SUTURE SUTURA

Mikro-Nadelhalter
 Micro-Needle-Holders
 Micro-porta-agujas
 Micro-porte-aiguilles
 Micro-portaghi



PATON
 AE 684/11
 11,0 cm/4¹/₂"



PATON
 AE 685/11
 11,0 cm/4¹/₂"

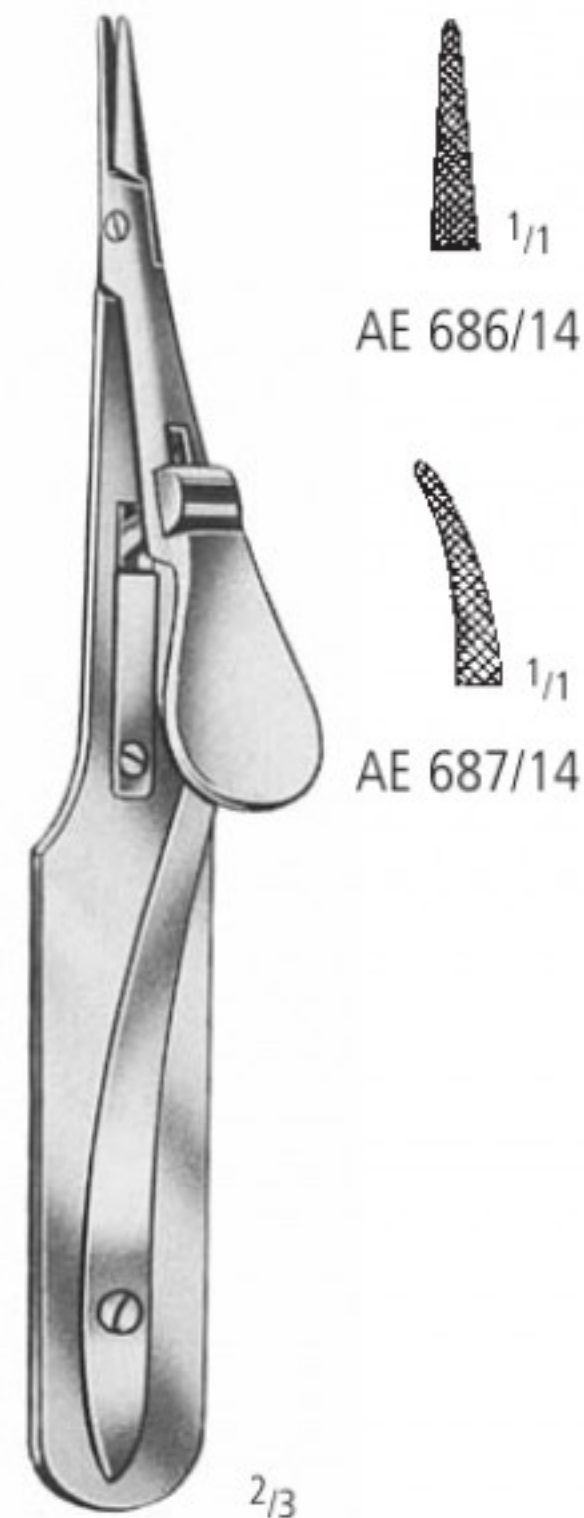

ARRUGA
 14,0 cm/5¹/₂"

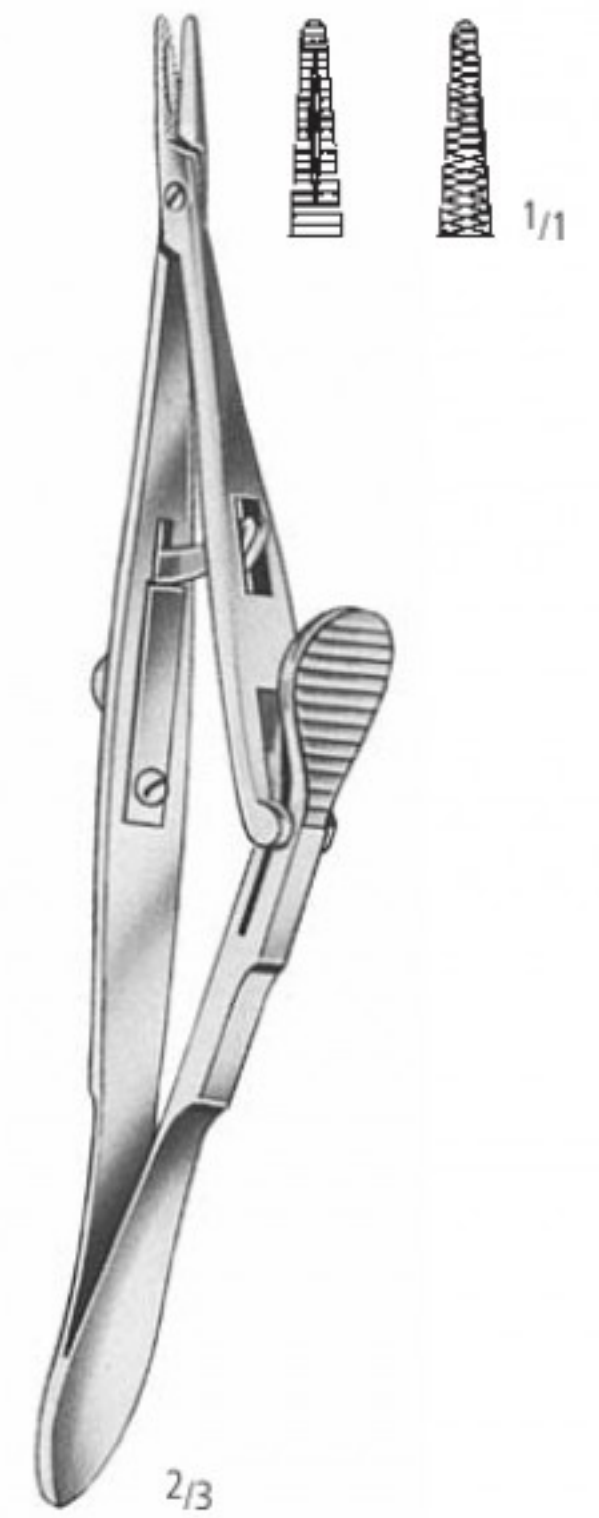

KALT
 AE 688/14
 14,0 cm/5¹/₂"

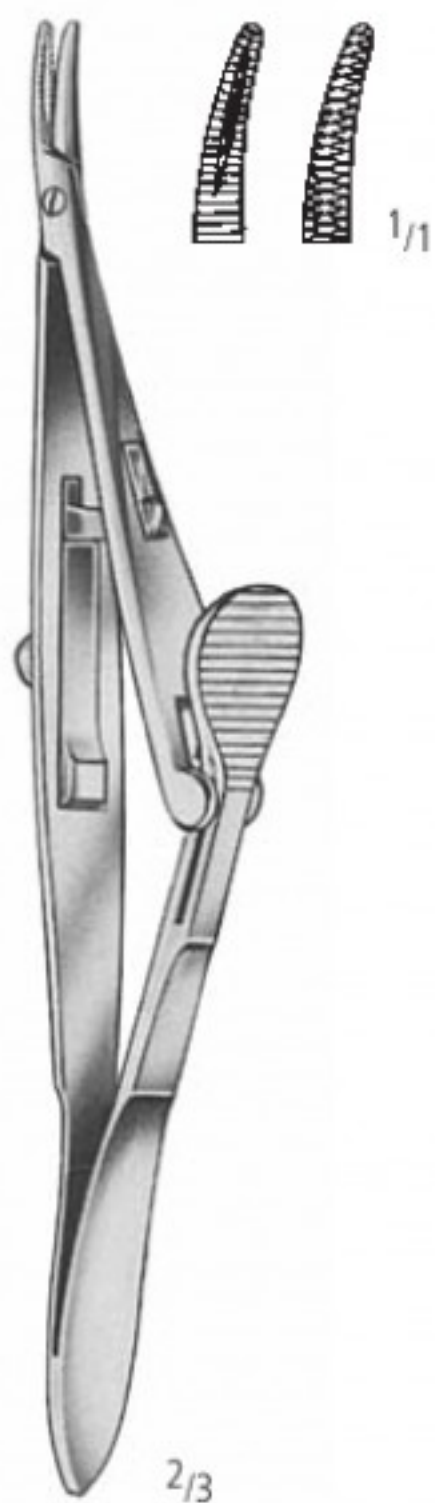

KALT-ARRUGA
 AE 689/14
 14,0 cm/5¹/₂"

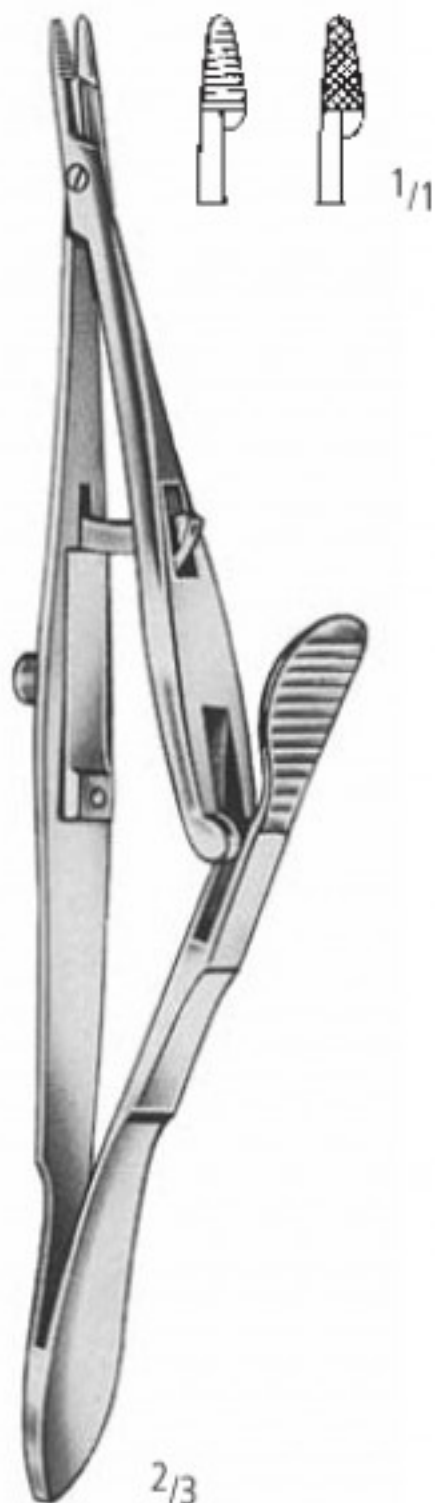

CASTROVIEJO-KALT
 AE 690/14
 13,5 cm/5¹/₄"



STEVENS
 AE 692/13 AE 692/15
 13,0 cm/5" 15,0 cm/6"

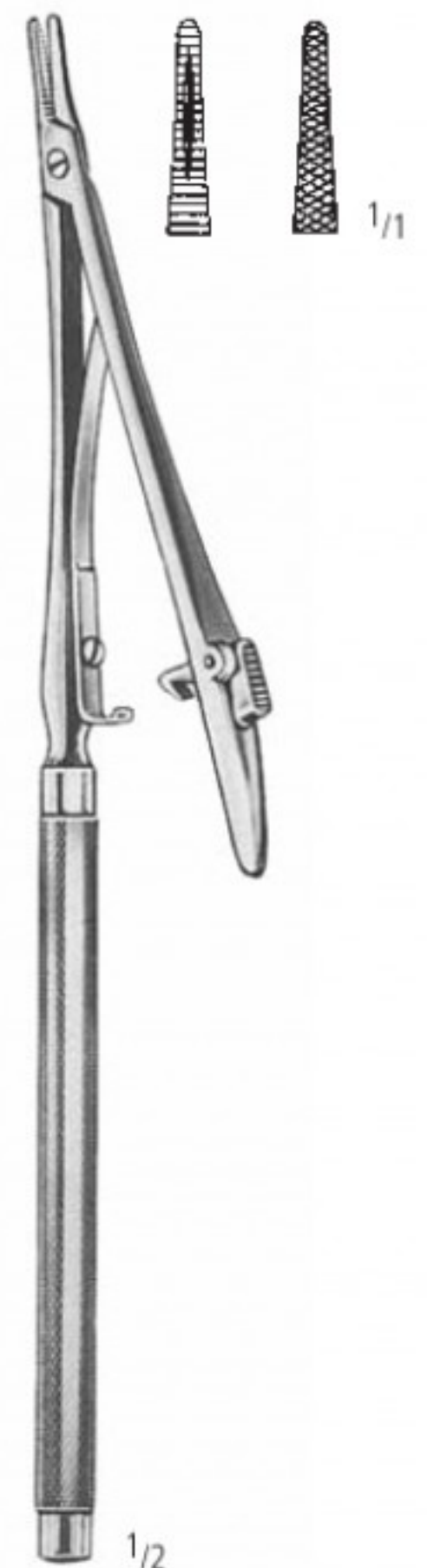

POTTS-SMITH
 AE 694/22
 22,0 cm/8³/₄"

NAHT SUTURE SUTURA SUTURE SUTURA

Mikro-Nadelhalter mit Rundgriff
 Micro-Needle-Holders with pen-type handle
 Micro-porta-agujas con mango redondo
 Micro-porte-aiguilles à manches rondes
 Micro-portaghi con manici rotondi

AA

AB

AC

AD

AE

AK

AR

KA

KM

KO

KP

KYE

XR

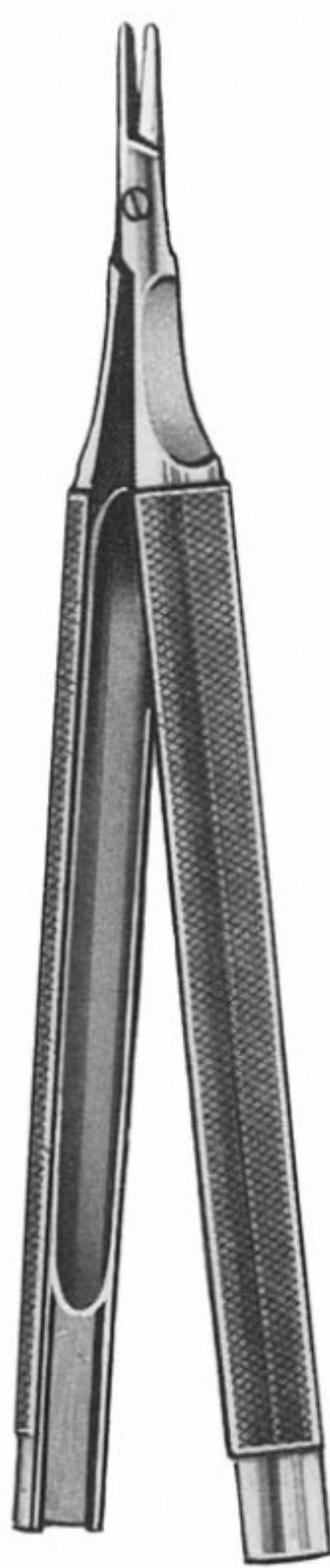

1/1
 AE 696/01
 1/1
 AE 696/02

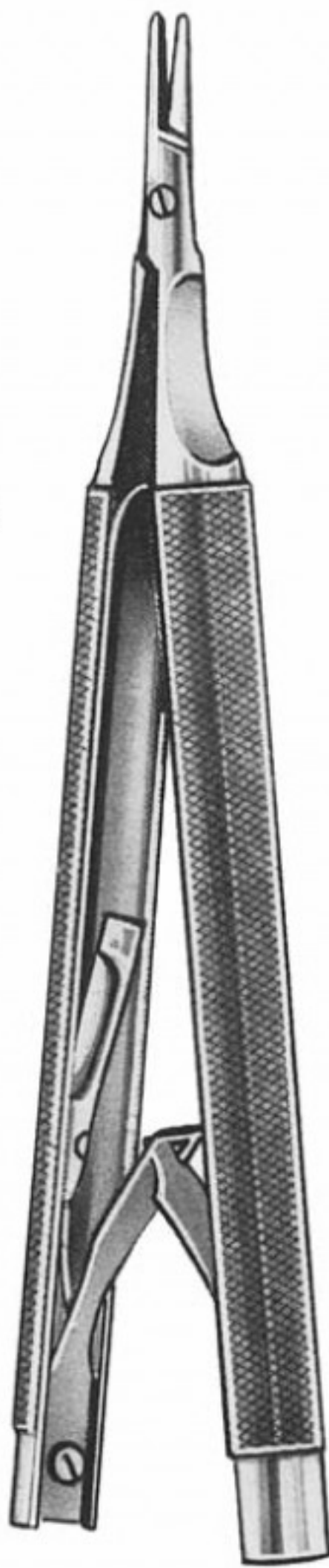

1/1
 AE 697/01
 1/1
 AE 697/02

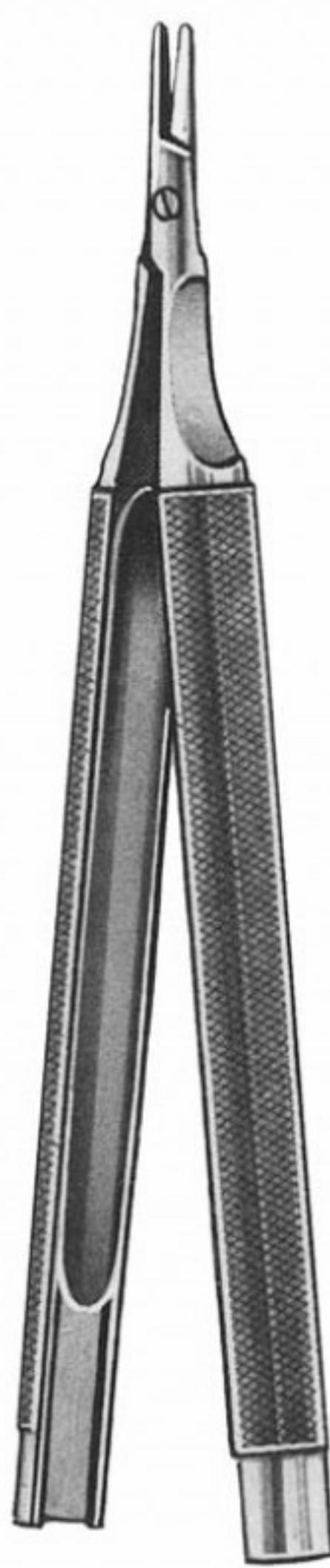

1/1
 AE 698/01
 1/1
 AE 698/02

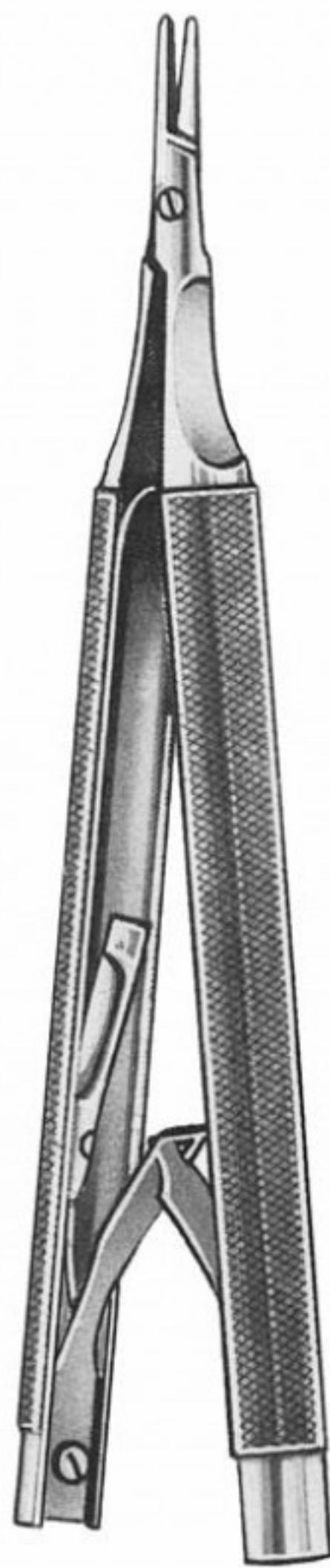

1/1
 AE 699/01
 1/1
 AE 699/02

CASTROVIEJO
 13,0 cm/5 1/4"

CASTROVIEJO
 13,0 cm/5 1/4"

CASTROVIEJO
 13,0 cm/5 1/4"

CASTROVIEJO
 13,0 cm/5 1/4"

Ø Griff 8 mm
 Ø Handle 8 mm
 Ø Mango 8 mm
 Ø Manche 8 mm
 Ø Manico 8 mm

Ø Griff 10 mm
 Ø Handle 10 mm
 Ø Mango 10 mm
 Ø Manche 10 mm
 Ø Manico 10 mm

WUNDHAKEN
RETRACTORS
SEPARADORES
ECARTEURS
DIVARICATORI

AK

nopa[®] instruments



WUNDHAKEN RETRACTORS SEPARADORES ECARTEURS DIVARICATORI

Feine Wundhaken
Delicate Hooks
Ganchos
Crochets très fins
Divaricatori sottili

AA

AB

AC

AD

AE

AK

AR

KA

KM

KO

KP

KYE

XR



GILLIES
AK 020/01
18,0 cm/7"



GILLIES
AK 020/02
18,0 cm/7"



KILNER
AK 022/15
15,0 cm/6"



FRAZIER
AK 024/13
13,0 cm/5"



AK 026/01



KLEINERT-KUTZ
AK 026/02
16,0 cm/6¹/₄"



AK 026/03

AK WUNDHAKEN RETRACTORS SEPARADORES ECARTEURS DIVARICATORI

Feine Wundhaken
Delicate Hooks
Ganchos
Crochets très fins
Divaricatori sottili

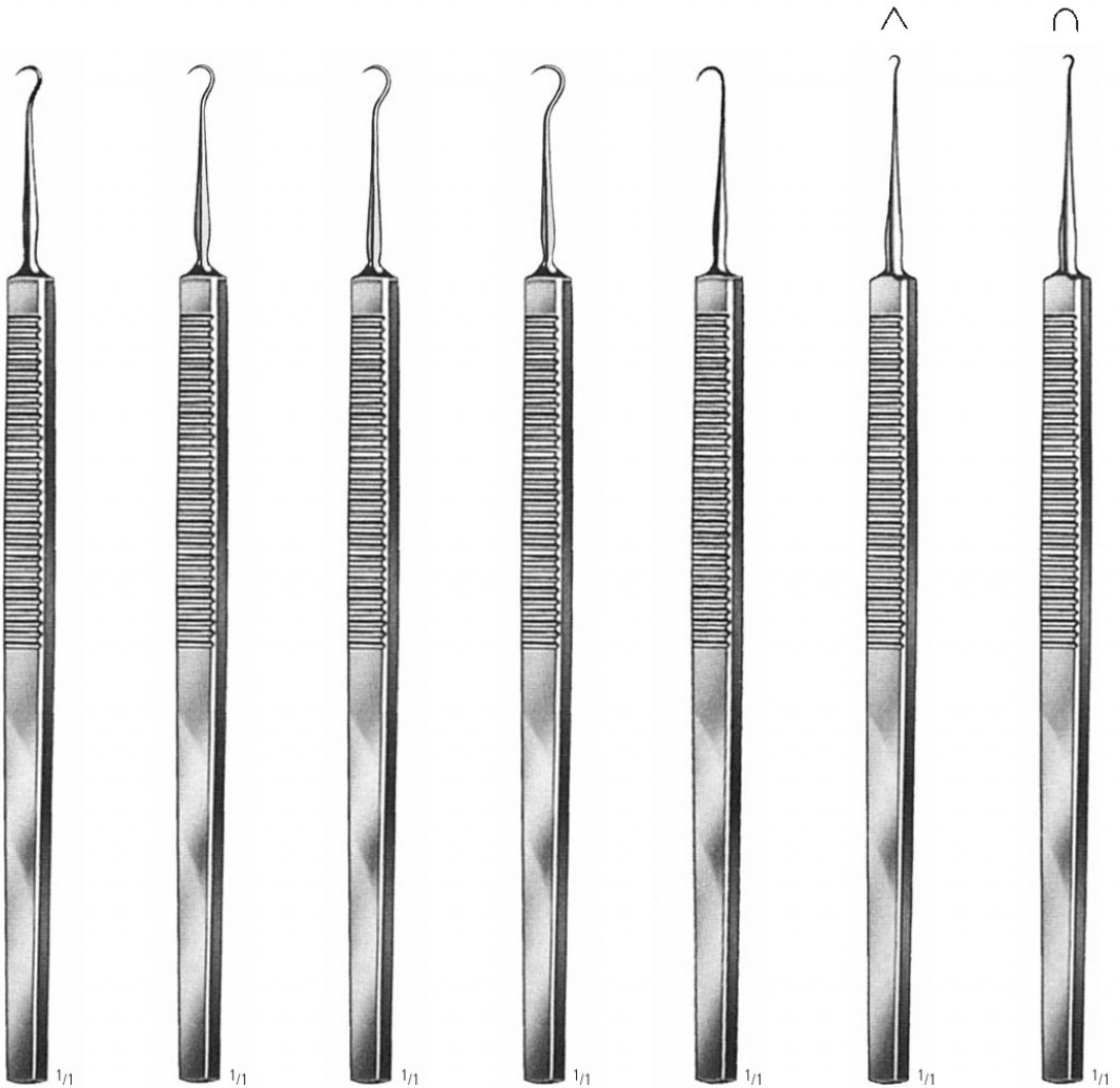

AK 028/01
16,0 cm/6¹/₄"

AK 028/02
16,0 cm/6¹/₄"

AK 028/03
16,0 cm/6¹/₄"

AK 028/04
16,0 cm/6¹/₄"

O' CONNOR
AK 030/16
16,0 cm/6¹/₄"

GRAEFE
AK 032/01
16,0 cm/6¹/₄"

GRAEFE
AK 032/02
16,0 cm/6¹/₄"

WUNDHAKEN RETRACTORS SEPARADORES ECARTEURS DIVARICATORI

Feine Wundhaken
Delicate Hooks
Ganchos
Crochets très fins
Divaricatori sottili

AA

AB

AC

AD

AE

AK

AR

KA

KM

KO

KP

KYE

XR



CUSHING
28,0 cm/11"



AK 034/01



AK 034/02



CUSHING
19,0 cm/7¹/₂"



AK 036/01



AK 036/02

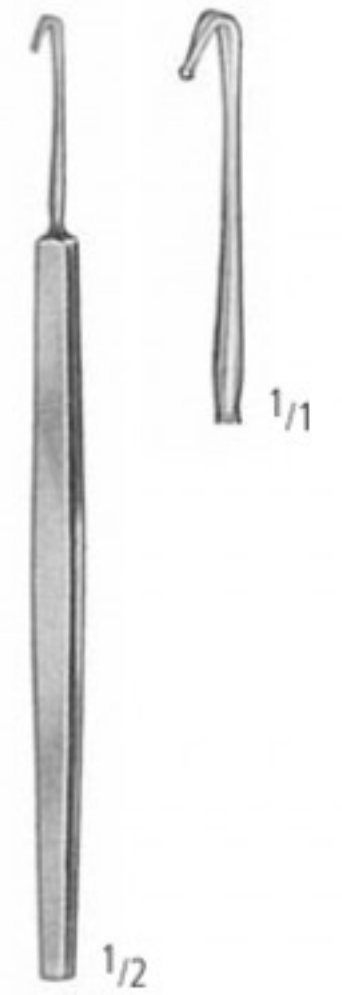

MOLDESTAD
AK 038/13
13,0 cm/5"



17,0 cm/6³/₄"



AK 040/05
5 mm



AK 040/07
7 mm



18,5 cm/7¹/₃"



AK 042/10
Ø 1,0 mm



AK 042/12
Ø 1,2 mm

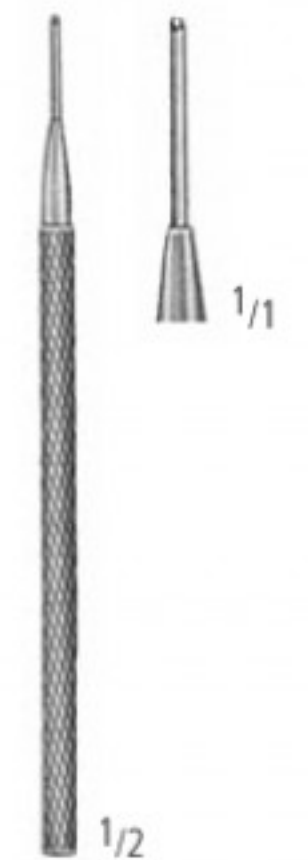

AK 044/11
11,0 cm/4¹/₃"

AK WUNDHAKEN RETRACTORS SEPARADORES ECARTEURS DIVARICATORI

Feine Wundhaken
Delicate Hooks
Ganchos
Crochets très fins
Divaricatori sottili

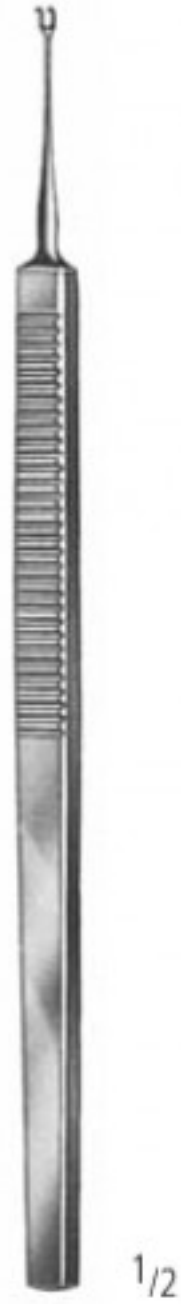

GUTHRIE
16,0 cm/6¹/₄"

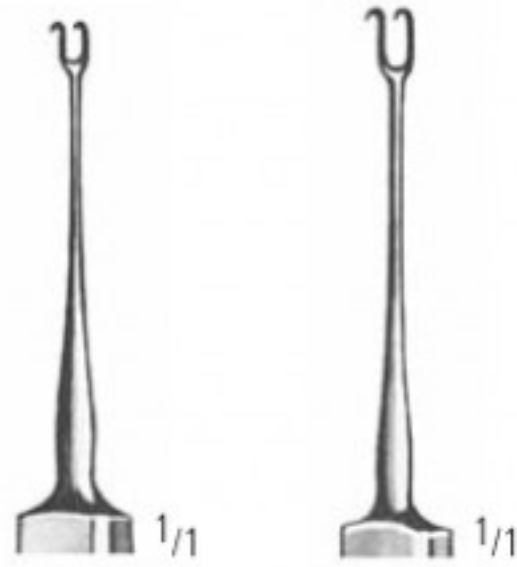

AK 074/01 AK 074/02



ROLLET
AK 076/13
13,0 cm/5"

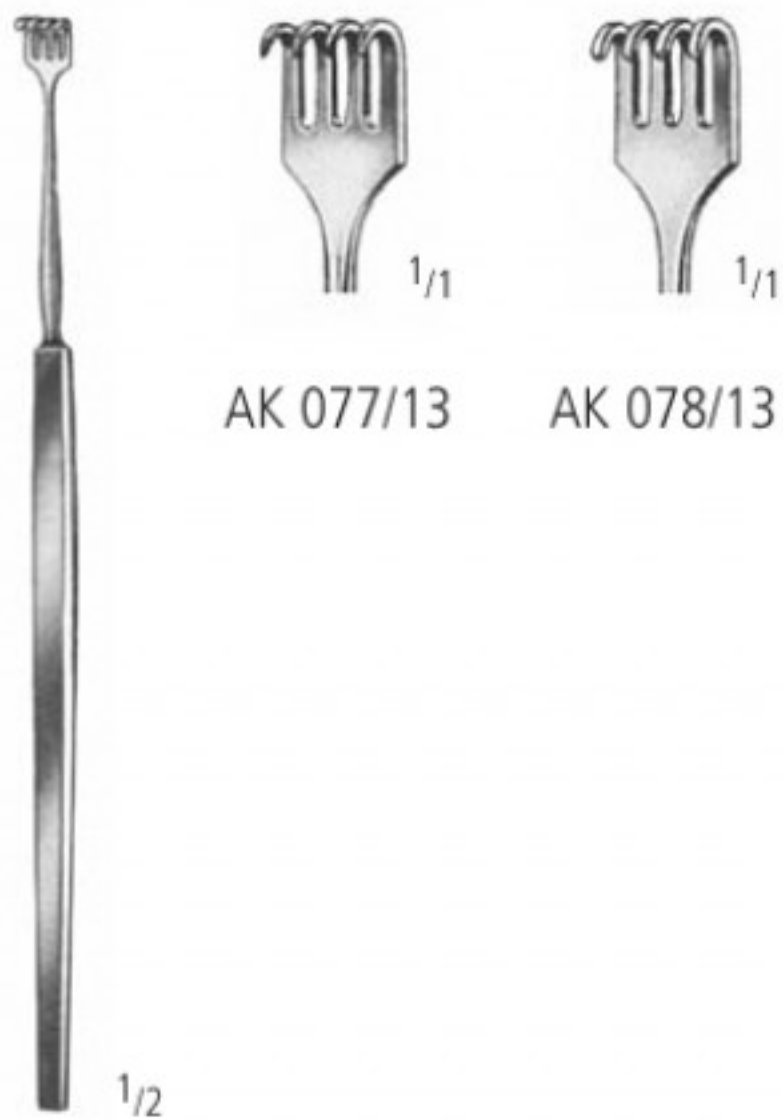

KNAPP
13,0 cm/5"



DESMARRES
13,0 cm/5"



AK 090/08
8 mm



AK 090/10
10 mm



AK 090/12
12 mm



AK 090/14
14 mm

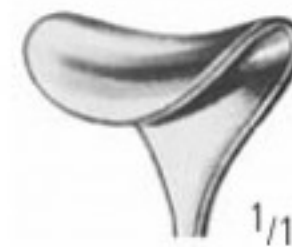

AK 090/16
16 mm



AK 090/18
18 mm

DIAGNOSTIK
DIAGNOSTICS
DIAGNOSTICO
DIAGNOSTIC
DIAGNOSTICA

AR

nopa[®] instruments



Messinstrumente
 Measuring Instruments
 Instrumentos para medidas
 Instruments pour mesurer
 Strumenti per misurare

AA

AB

AC

AD

AE

AK

AR

KA

KM

KO

KP

KYE

XR



1/2

AR 250/15
 15,0 cm/6"



1/1

JAMESON
 AR 261/08
 0 - 80 mm/0-3 inch



1/1

CASTROVIEJO
 AR 282/15
 8,0 cm/3 1/4"

Messbereich 15 mm
 measuring range 15 mm
 campo de medición 15 mm
 étendue de mesurage 15 mm
 ampiezza di misura 15 mm



1/1

CASTROVIEJO
 AR 282/20
 8,0 cm/3 1/4"

Messbereich 20 mm
 measuring range 20 mm
 campo de medición 20 mm
 étendue de mesurage 20 mm
 ampiezza di misura 20 mm



1/1

CASTROVIEJO
 AR 283/20
 8,0 cm/3 1/4"

Messbereich 20 mm
 measuring range 20 mm
 campo de medición 20 mm
 étendue de mesurage 20 mm
 ampiezza di misura 20 mm

Ophthalmoskop
Ophthalmoscope
Oftalmoscopio
Ophtalmoscope
Oftalmoscopio



OTO- / OPHTHALMOSKOP
AR 402/00



OPHTHALMOSKOP
AR 420/00

ORTHOPÄDIE
ORTHOPAEDICS
ORTOPEDIA
ORTHOPEDIE
ORTOPEDIA

KA

nopa[®] instruments



Meißeln, Hammer und Hohlmeißelzangen
 Chisels, Mallet and Bone Rongeurs
 Cinceles, Martillo, Pinzas-gubias
 Ciseaux-burins, Marteau, Pincès-gouges
 Scalpelli, Martello e Pinze-sgorbie



1/2



1/2

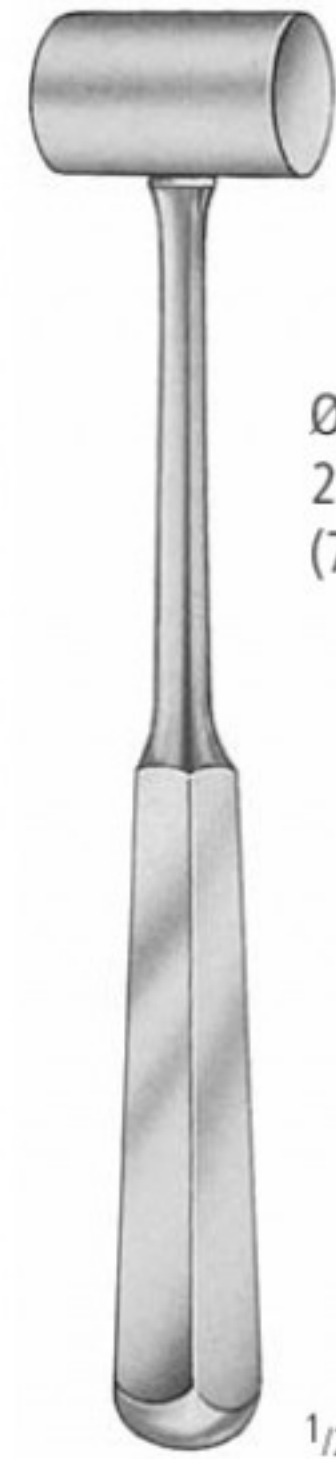

Ø 22 mm
 200 g
 (7 oz.)

1/2

PARTSCH
 13,5 cm/5 1/4"

- KA 433/02
- KA 433/03
- KA 433/04
- KA 433/05
- KA 433/06
- KA 433/07

mm

- 2
- 3
- 4
- 5
- 6
- 7

- KA 443/02
- KA 443/03
- KA 443/04
- KA 443/05
- KA 443/06
- KA 443/07

PARTSCH
 KA 545/20
 18,0 cm/7"

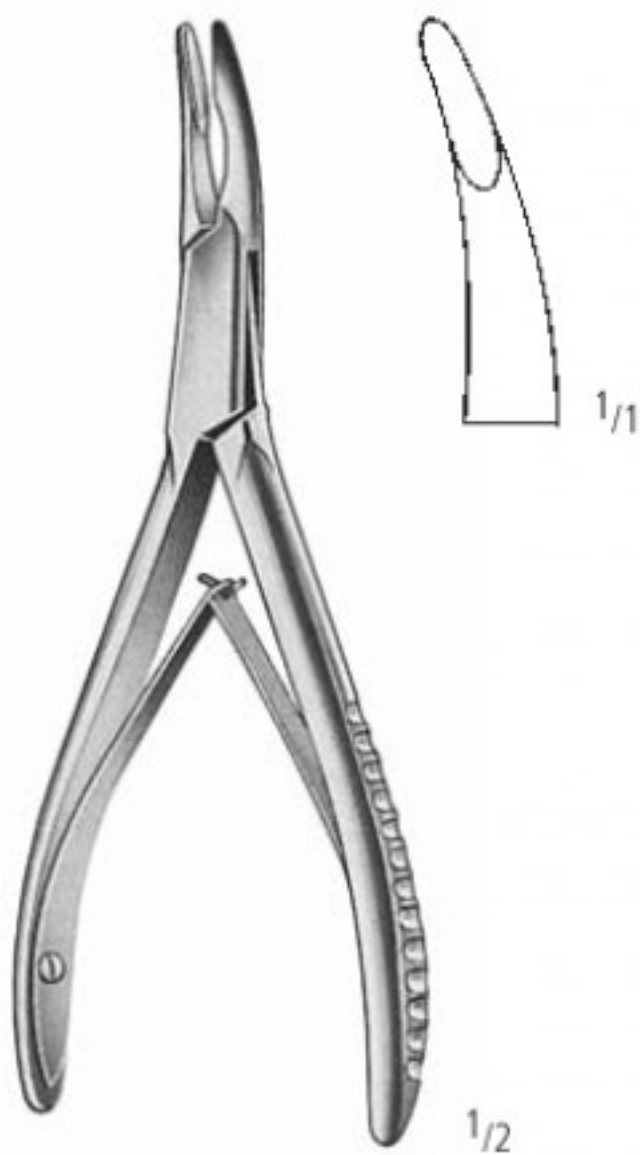

1/1

1/2

FRIEDMAN
 KA 800/14
 14,0 cm/5 1/2"



1/2

LUER
 17,0 cm/6 3/4"

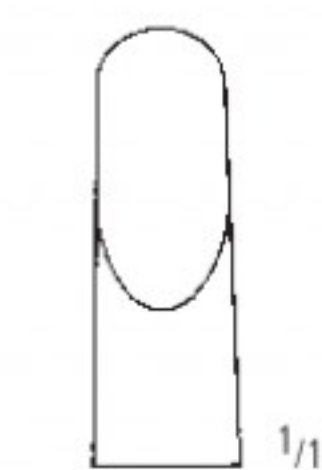

1/1

KA 812/17



1/1

KA 813/17

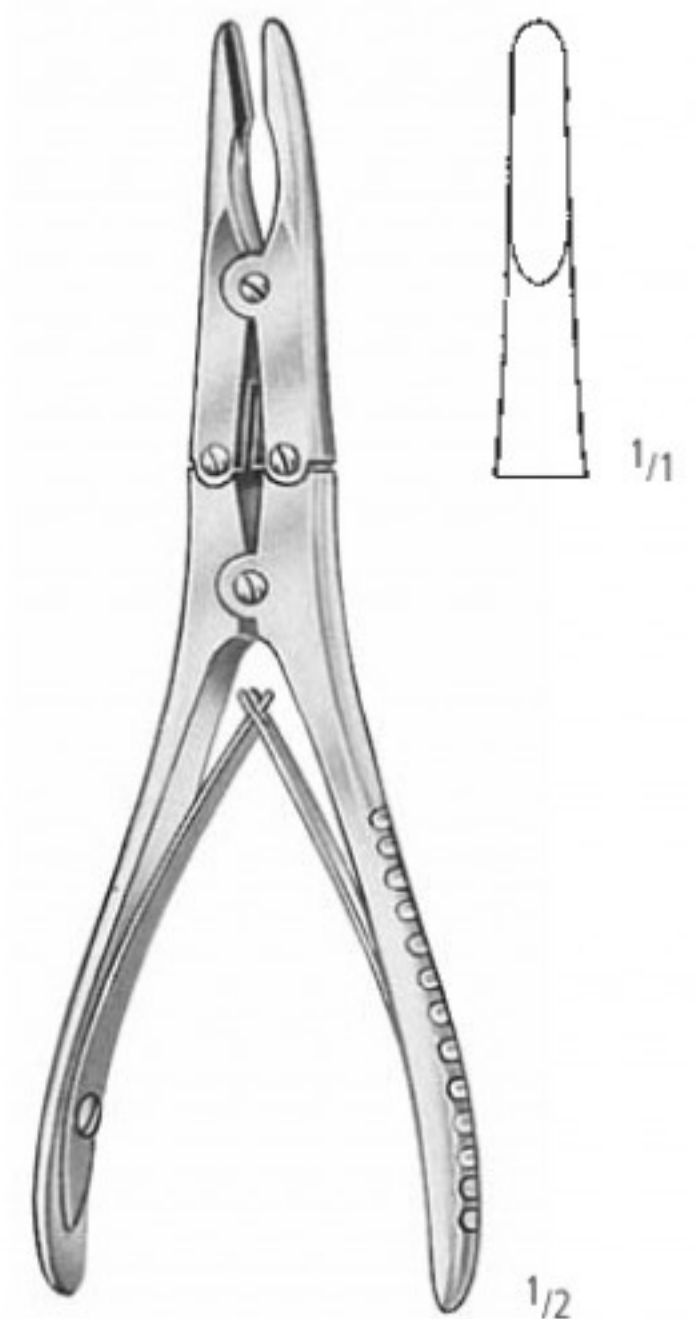

1/1

1/2

BÖHLER
 KA 825/01
 15,0 cm/6"

OTOLOGIE
OTOLOGY
OTOLOGIA
OTOLOGIE
OTOLOGIA

KM

nopa[®] instruments



Stanzen
 Punches
 Pinzas osteótomos
 Pincas ostéotomes
 Pinze osteotomi



CITELLI

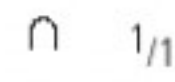

KM 490/01
 1 mm



KM 490/02
 2 mm



KM 490/03
 3 mm

1/2

RHINOLOGIE
RHINOLOGY
RINOLOGIA
RHINOLOGIE
RINOLOGIA

KO

nopa[®] instruments



KO NASE RHINOLOGY RINOLOGIA RHINOLOGIE RINOLOGIA

Nasenspekula, Keilbeinstanzen
 Nasal Specula, Sphenoid Punches
 Espéculos nasales, Pinzas para seno esfenoidal
 Spéculums nasaux, Pincés pour sinus sphénoïdal
 Specoli nasali, Pinze per seno sfenoidale

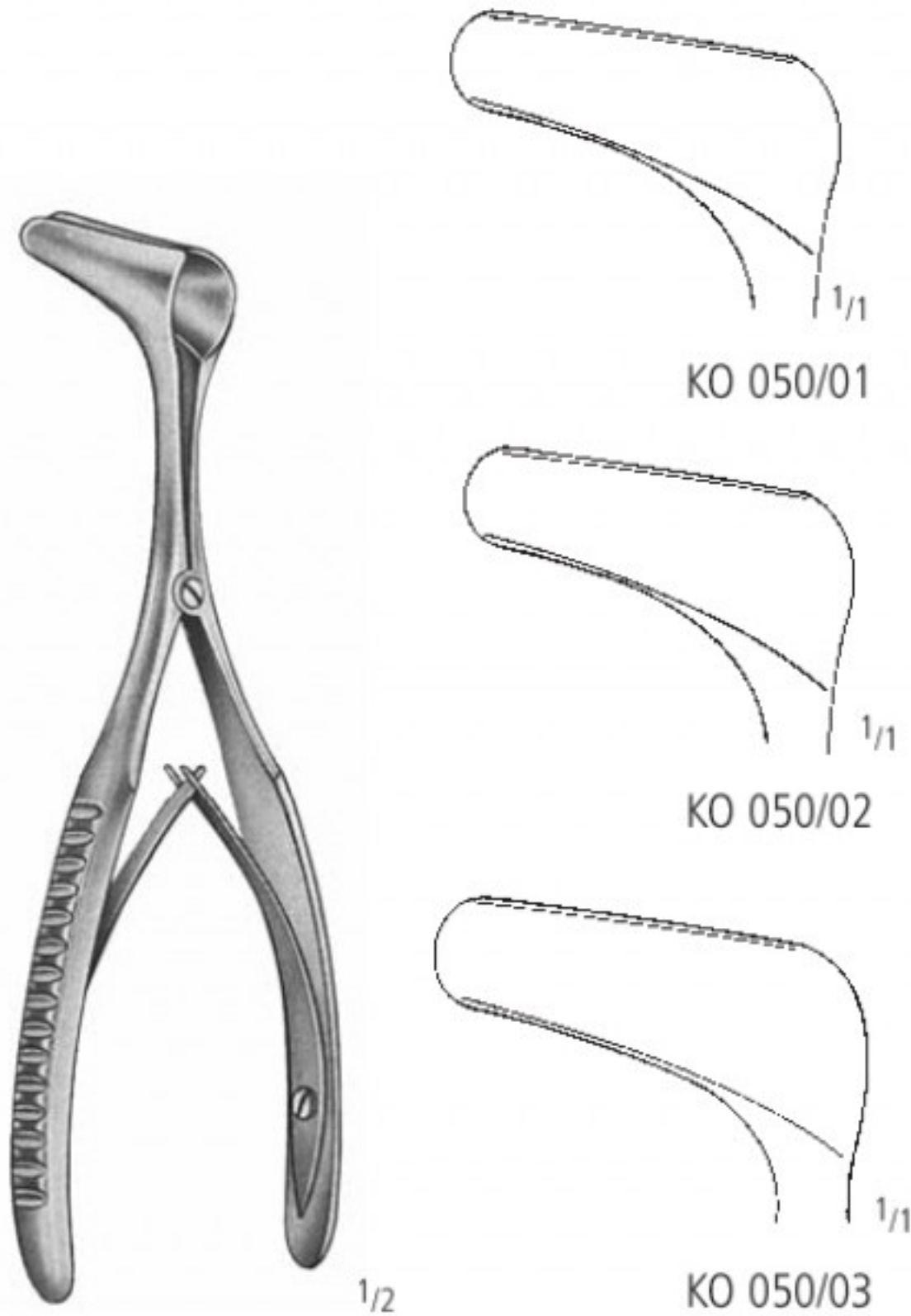

HARTMANN-HALLE
 15,0 cm/6"



KERRISON

Hohlmeißel
 Gouges
 Gubias
 Gouges
 Sgorbie

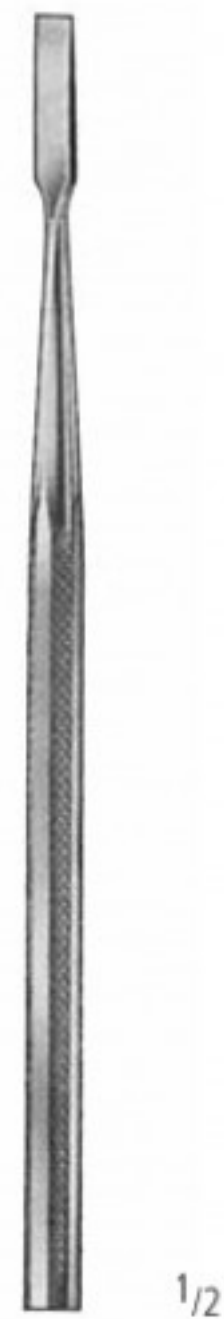

WEST
 KO 604/04
 16,0 cm/6 1/4"

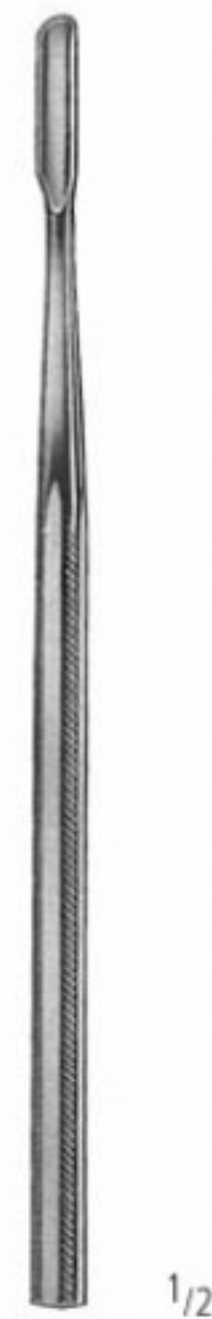

WEST
 KO 605/04
 16,0 cm/6 1/4"

OPHTHALMOLOGIE
 OPHTHALMOLOGY
 OFTALMOLOGIA
 OPHTHALMOLOGIE
 OFTALMOLOGIA

KP

nopa[®] instruments

Haken	Seite	105-	Löffel, Spatel	Seite	136-
Hooks	Page	105-	Spoons, Spatulas	Page	136-
Ganchos	Página	105-	Cucharas, Espátulas	Página	136-
Crochets	Page	105-	Cuillers, Spatules	Page	136-
Uncinetti	Página	105-	Cucchiaio, Spatole	Página	136-
Sonden	Seite	115-	Markierinstrumente	Seite	142-
Probes	Page	115-	Markers	Page	142-
Sondas	Página	115-	Marcadores	Página	142-
Sondes	Page	115-	Marqueurs	Page	142-
Sonde	Página	115-	Marcatori	Página	142-
Lidsperrer	Seite	118-	Bohrer, Trephinen	Seite	147-
Eye Speculas	Page	118-	Burrs, Trephines	Page	147-
Blefaróstatos	Página	118-	Fresas, Trépanos	Página	147-
Blépharostats	Page	118-	Trépan	Page	147-
Blefarostati	Página	118-	Trepani	Página	147-
Messer	Seite	125-	Kanülen	Seite	150-
Knives	Page	125-	Cannulas	Page	150-
Cuchillos	Página	125-	Cánulas	Página	150-
Couteaux	Page	125-	Canules	Page	150-
Coltelli	Página	125-	Cannule	Página	150-



Muskel-, Netzhautablösungs- und Schielhaken
 Muscle, Retinal Detachment and Strabismus Hooks
 Ganchos de músculos, para desprendimiento de retina y para estrabismo
 Crochets musculaires, de décollement de la rétine et à strabisme
 Uncinetti per muscoli e per strabismo



GREEN
 KP 001/13
 13,0 cm/5"

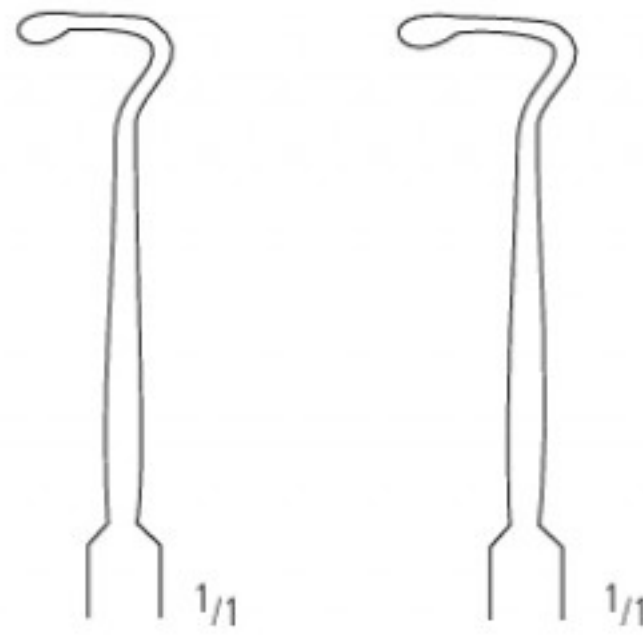

JAMESON
 KP 002/12 KP 002/13
 12,0 cm/4³/₄" 13,0 cm/5"



GASS
 KP 010/14
 14,0 cm/5¹/₂"



GRAEFE
 KP 015/01
 13,0 cm/5"
 Fig. 1

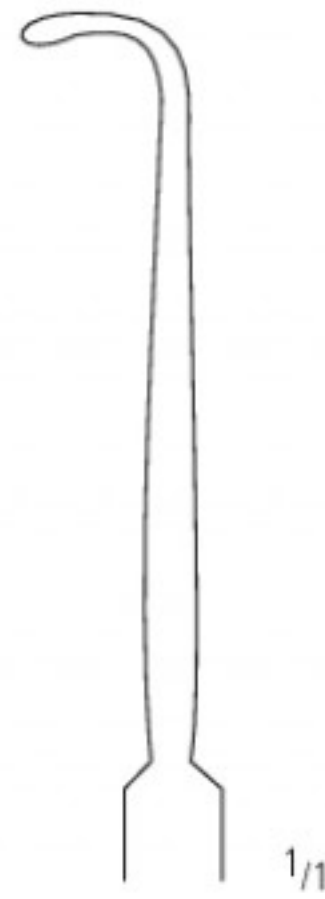

GRAEFE
 KP 015/02
 14,0 cm/5¹/₂"
 Fig. 2

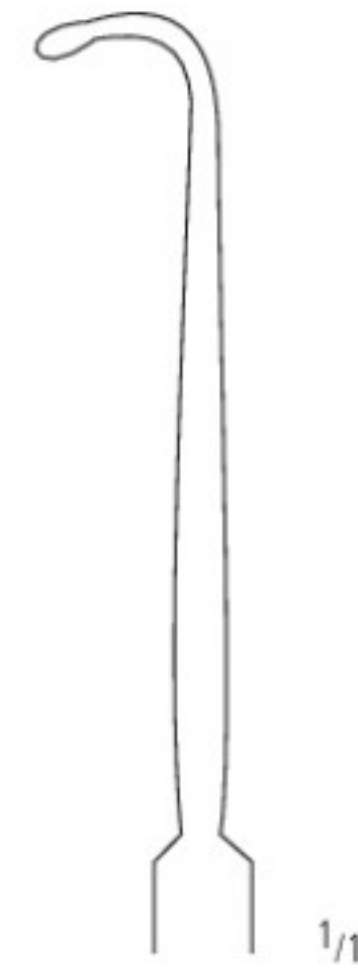

GRAEFE
 KP 015/03
 15,0 cm/6"
 Fig. 3

Sehnenhäkchen, Fixiergabel
 Tenotomy Hook, Fixation Fork
 Gancho de tenotomía, Horquilla fijadora
 Crochet pour tenotomie, Pique de fixation
 Uncinetti de tendini e per fissazione

AA

AB

AC

AD

AE

AK

AR

KA

KM

KO

KP

KYE

XR



STEVENS
 KP 018/12
 12,0 cm/4³/₄"



BURCH
 KP 020/13
 13,0 cm/5"

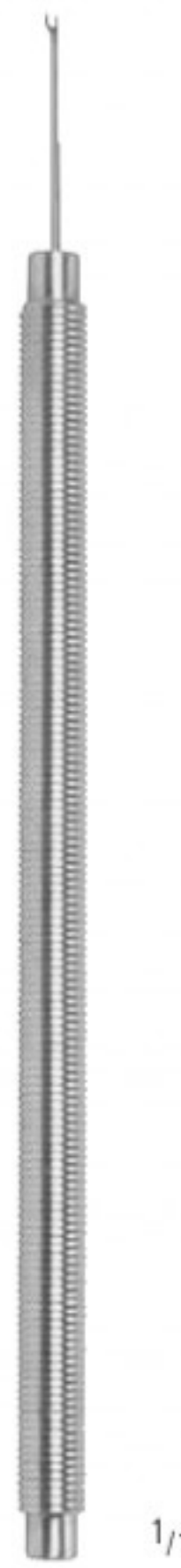

KP 023/01
 11,0 cm/4¹/₂"

rechts
 right
 derecha
 droit
 destra

KP 023/02
 11,0 cm/4¹/₂"

links
 left
 izquierda
 gauche
 sinistra

Irishäkchen
Iris Hooks
Ganchos para iris
Crochets à iris
Uncinetti per l'iride



sehr fein, scharf
very delicate, pointed
delicadísimo, afilado
très fin, coupant
fino, tagliente

BONN
KP 025/14
13,5 cm/5¹/₄"



stumpf
blunt
romo
émoussé
smussato

KNOLLE
KP 026/11
11,0 cm/4¹/₂"

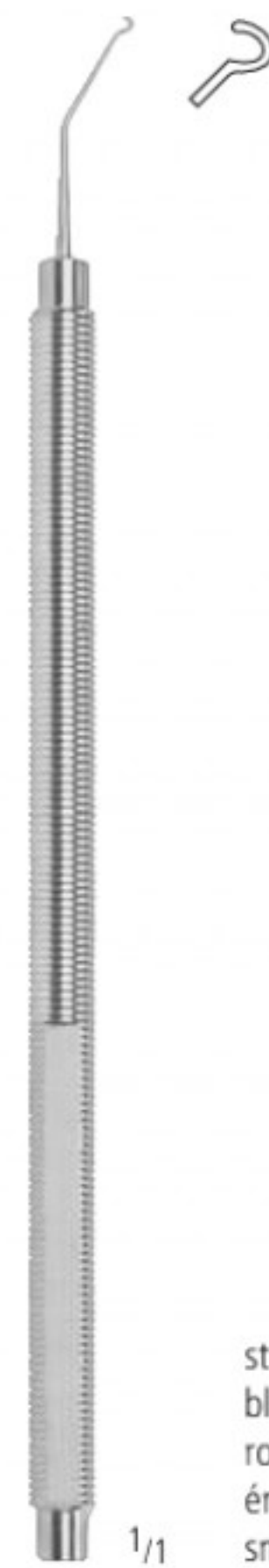

stumpf, abgewinkelt
blunt, angled
romo, angular
émoussé, coudé
smussato, angolato

JAFFE-KNOLLE
KP 027/12
12,0 cm/4³/₄"

Irishäkchen
Iris Hooks
Ganchos para iris
Crochets à iris
Uncinetti per l'iride

AA

AB

AC

AD

AE

AK

AR

KA

KM

KO

KP

KYE

XR



1/1

TYRELL
12,0 cm/4³/₄"



KP 029/01

stumpf
blunt
romo
émoussé
smussato



KP 029/02

scharf
pointed
afilado
coupant
tagliante

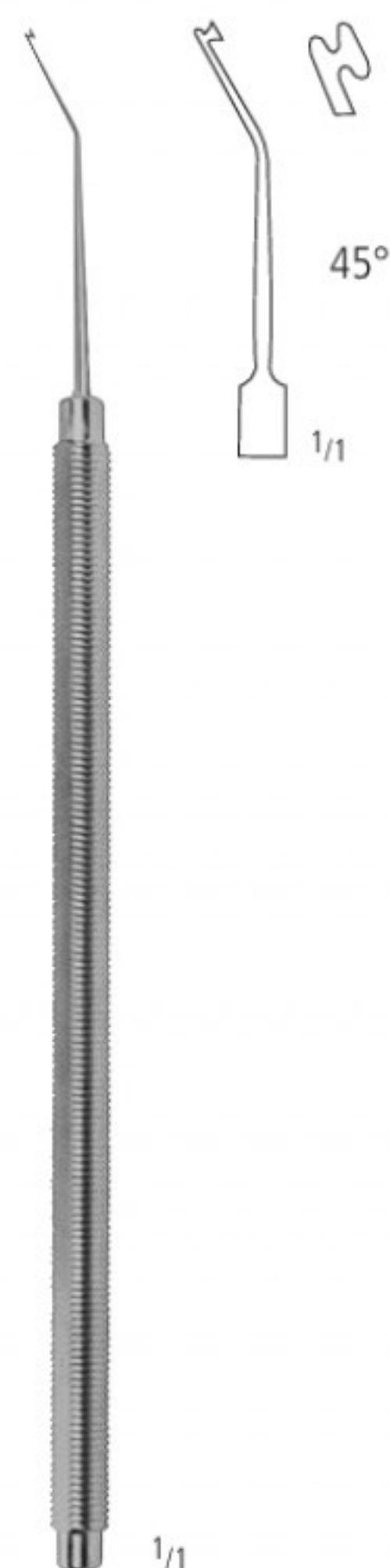

1/1

HIRSCHMANN
KP 030/13
12,5 cm/5"

Linsenkernwender, Linsenmanipulator
 Lens Nucleus Rotators, Lens Manipulators
 Ganchos para voltear nucleo y para posicionar cristalino
 Crochets pour tourner, Crochets manipulateurs à cristallin
 Uncinetti per rotazione di nucleo cristallino, Uncini per posizionare cristallino

TITANIUM



BECHERT
 KP 040/01
 12,0 cm/4³/₄"
 L = 7 mm

V-Spitze
 V-tip
 punta V
 coudé à fourche
 punta V

1/1



JAFFE-BECHERT
 KP 040/02
 12,0 cm/4³/₄"
 L = 9 mm

V-Spitze
 V-tip
 punta V
 coudé à fourche
 punta V



CLAYMAN
 KP 040/03
 12,5 cm/5"
 L = 10 mm

V-Spitze
 V-tip
 punta V
 coudé à fourche
 punta V

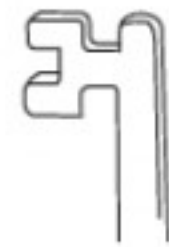

OSHER
 KP 050/12
 12,0 cm/4³/₄"

1/1

Linsenkernmanipulatoren, Phakohaken
 IOL Manipulators, Phaco Splitter
 Ganchos para manipular de nucleo, Ganchos para faco
 Crochets pour manipuler le noyau, Crochets à phaco
 Uncini per posizionare cristallino, Uncini per faco

AA

AB

AC

AD

AE

AK

AR

KA

KM

KO

KP

KYE

XR

TITANIUM

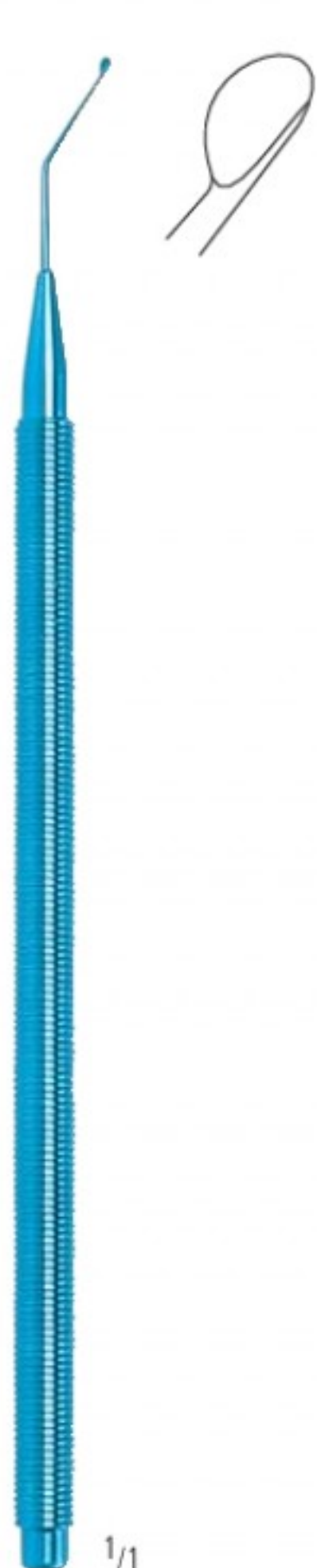

DRYSDALE
 KP 051/12
 12,0 cm/4³/₄"



BUNNKATU
 KP 057/12
 12,0 cm/4³/₄"



Klinge
 blade
 hoja
 lame
 lame

Klinge
 blade
 hoja
 lame
 lame



ROSEN
 12,0 cm/4³/₄"

KP 065/60

KP 065/90

60°

90°

stumpfes Eck
 blunt edge
 canto romo
 coin mousse
 angolo smussato



NAGAHARA
 12,0 cm/4³/₄"

KP 067/60

KP 067/90

60°

90°

stumpfes Eck
 blunt edge
 canto romo
 coin mousse
 angolo smussato

IOL Positionshäkchen
 Lens Manipulators
 Ganchos para posicionar cristalino
 Crochets manipulateurs à cristallin
 Uncini per posizionare cristallino

TITANIUM

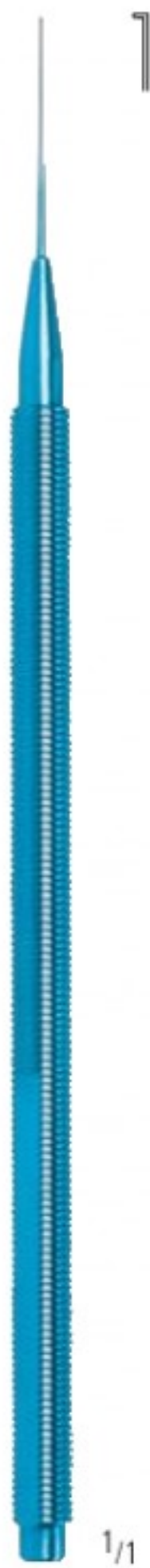

1/1

KP 070/20
 KP 070/25

SINSKEY
 12,0 cm/4³/₄"

Ø 0,20 mm
 Ø 0,25 mm

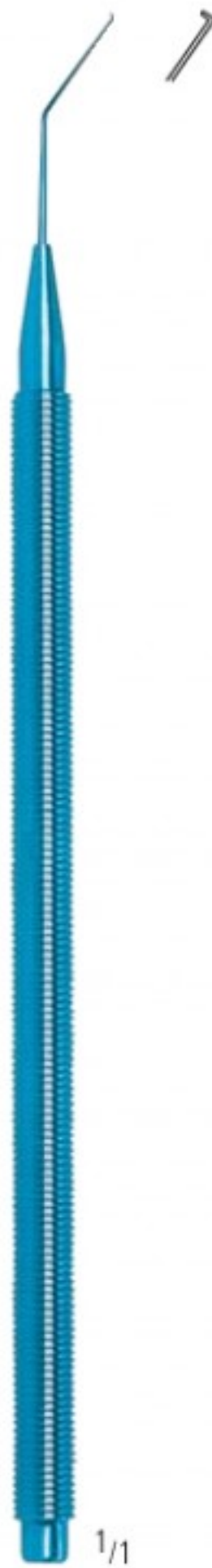

1/1

KP 071/20
 KP 071/25

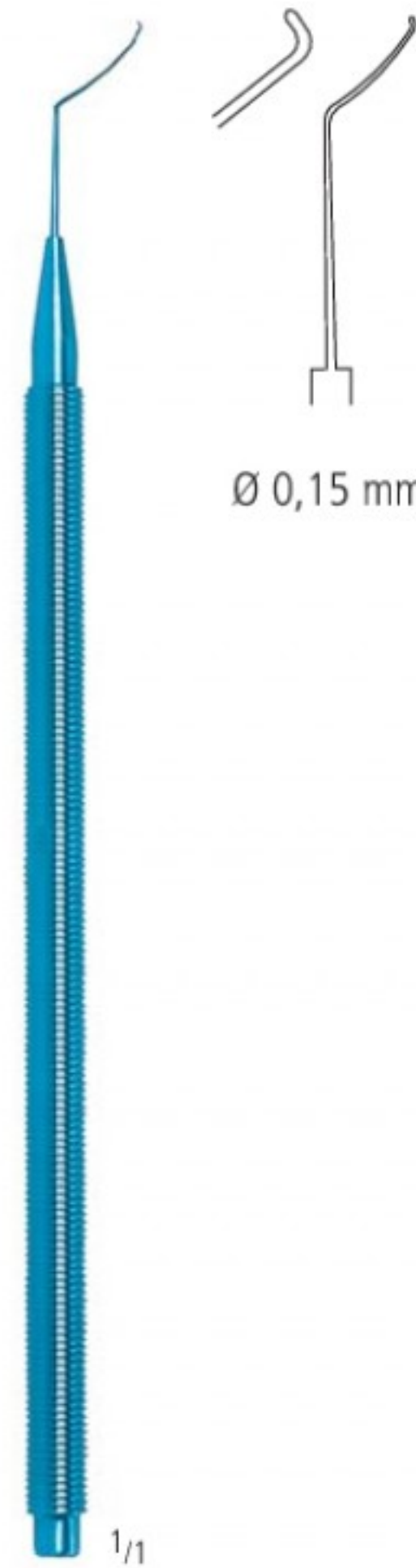

Ø 0,15 mm

LEWICKY
 KP 075/15
 12,0 cm/4³/₄"

IOL Positionshäkchen
 Lens Manipulators
 Ganchos para posicionar cristalino
 Crochets manipulateurs à cristallin
 Uncini per posizionare cristallino

AA

AB

AC

AD

AE

AK

AR

KA

KM

KO

KP

KYE

XR

TITANIUM



1/1

LESTER
 KP 077/01
 12,0 cm/4³/₄"



1/1

LESTER
 KP 077/02
 12,0 cm/4³/₄"



LESTER
 KP 077/03
 12,0 cm/4³/₄"

gewölbt
 vaulted
 abovedado
 cintré
 convesso



JAFFE-MALTZMANN
 KP 081/12
 12,0 cm/4³/₄"

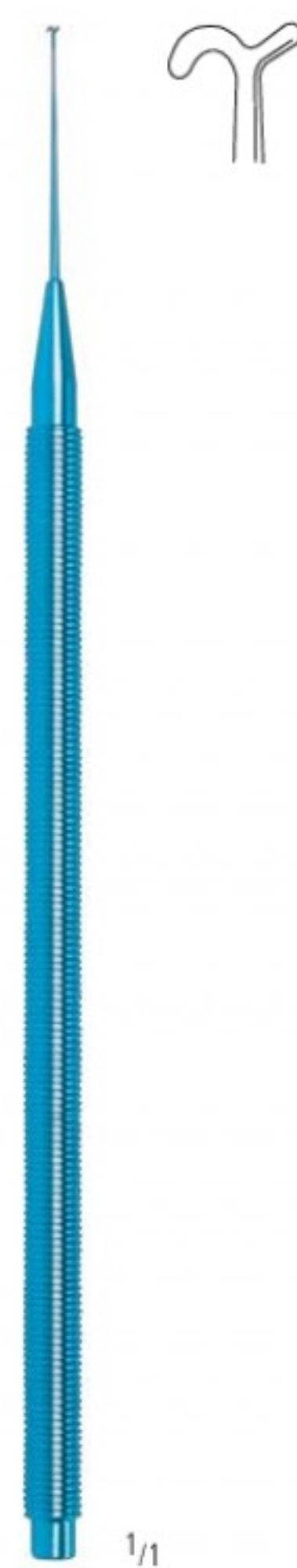

1/1

RENTSCH
 KP 085/12
 12,0 cm/4³/₄"

Tränenkanalsonden
 Lacrimal Probes
 Sondas exploradoras para canal lacrimal
 Sondes exploratrices pour le canal lacrymal
 Sonde esploratrici per canale lacrimale

AA

AB

AC

AD

AE

AK

AR

KA

KM

KO

KP

KYE

XR



geknöpft
 pointed
 con botón
 boutoné
 bottenuto

- KP 114/00
- KP 115/00
- KP 115/01
- KP 115/12
- KP 115/23
- KP 115/34
- KP 115/45
- KP 115/56
- KP 115/67
- KP 115/78

Fig.	mm Ø
0000/00	0,4 / 0,6
00/0	0,7 / 0,8
0/1	0,8 / 0,9
1/2	0,9 / 1,1
2/3	1,1 / 1,3
3/4	1,3 / 1,4
4/5	1,4 / 1,5
5/6	1,5 / 1,6
6/7	1,6 / 1,8
7/8	1,8 / 1,9



zylindrisch
 cylindrical
 cilíndrica
 cylindrique
 cilindrico

- KP 116/00
- KP 117/00
- KP 117/01
- KP 117/12
- KP 117/23
- KP 117/34
- KP 117/45
- KP 117/56
- KP 117/67
- KP 117/78



BOWMAN
 12,5 cm/5"

aus Silber
 Sterling silver
 de plata pura
 en argent pur
 in argento puro

BOWMAN
 12,5 cm/5"

Tränenkanaldilatatoren
 Lacrimal Dilators
 Dilatadoras para canal lacrimal
 Dilatateurs pour le canal lacrymal
 Dilatatori per canale lacrimale



WILDER
 10 cm/4"



KP 120/01
 Fig. 1

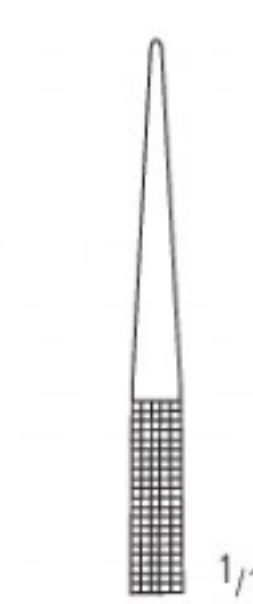

KP 120/02
 Fig. 2



KP 120/03
 Fig. 3

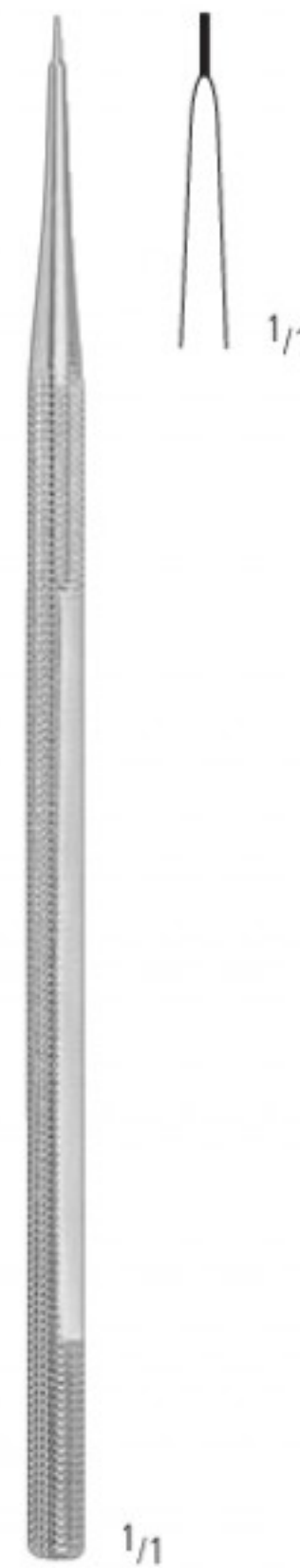

MULDOON
 KP 121/11
 10,5 cm/4¹/₄"

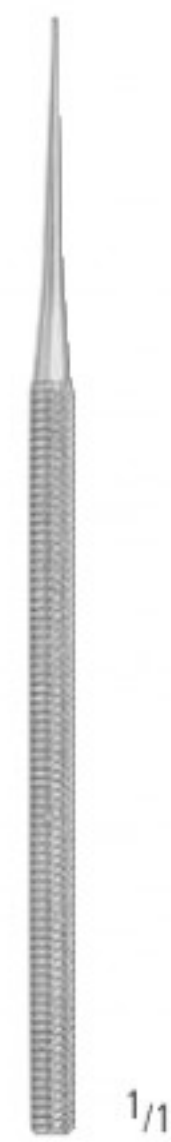

RUEDEMANN
 KP 122/07
 7 cm/2³/₄"

Tränenkanaldilatatoren, Trabekularsonden, Pigtail Sonde
 Lacrimal Dilators, Trabecular Probes, Pigtail Probe
 Dilatadoras para canal lacrimal, Sondas trabeculares, Sonda pigtail
 Dilatateurs pour le canal lacrymal, Sondes trabéculaires, Sonde spiralée
 Dilatatori per canale lacrimale, Sonde trabecolari, Sonda a pigtail

AA

AB

AC

AD

AE

AK

AR

KA

KM

KO

KP

KYE

XR



CASTROVIEJO
 KP 123/14
 14 cm/5 1/2"



KP 130/01
 rechts
 right
 derecha
 droit
 destra



HARMS
 4,5 cm/1 3/4"

KP 130/02
 links
 left
 izquierda
 gauche
 sinistra

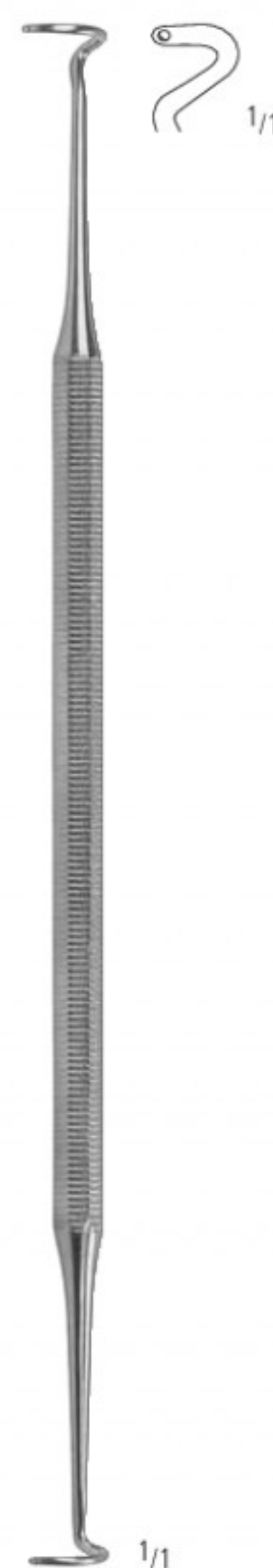

WORST
 KP 135/14
 13,5 cm/5 1/4"

Lidsperrer
Eye Specula
Blefarostatos
Blépharostats
Blefarostati

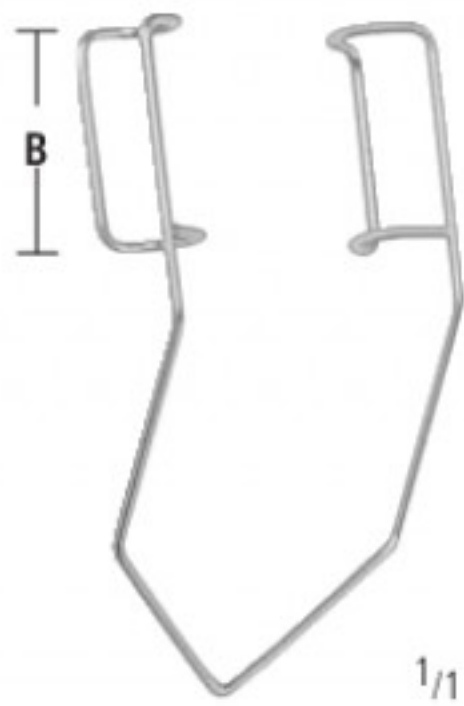

BARRAQUER-COLIBRI

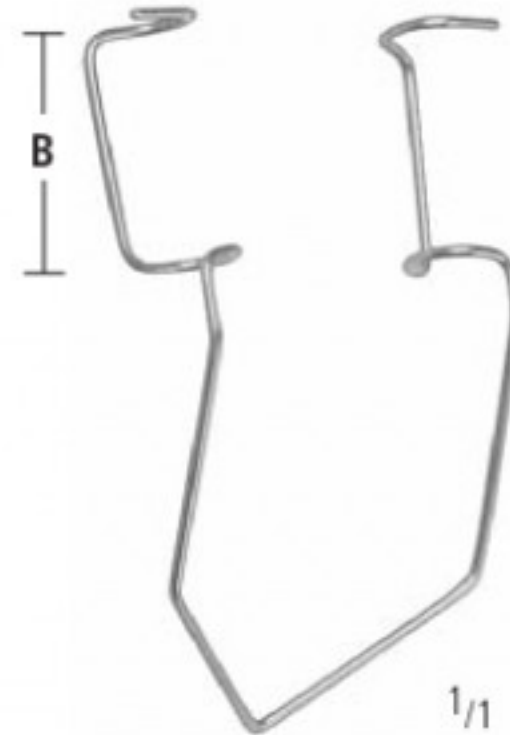

KRATZ-BARRAQUER



BARRAQUER

geschlossene Valven
solid blades
hojas sólidas
cuillers plaines
valve massiccio

Frühgeborene
Premature infant
Parto prematuro
Acchouchement prématuré
Parto prematuro

B
5 mm KP 150/05
3,0 cm/1¹/₄"

Kind
Child
Niños
Enfants
Bambini

10 mm KP 150/10
3,0 cm/1¹/₄"

B
10 mm KP 151/10
4,0 cm/1¹/₂"

B
10 mm KP 152/10
4,0 cm/1¹/₂"

Erwachsene
Adults
Adultos
Adultes
Adulti

15 mm KP 150/15
4,0 cm/1¹/₂"

14 mm KP 151/14
4,5 cm/1³/₄"

15 mm KP 152/15
4,0 cm/1¹/₂"



BARRAQUER PHAKO
KP 154/04
4,0 cm/1¹/₂"

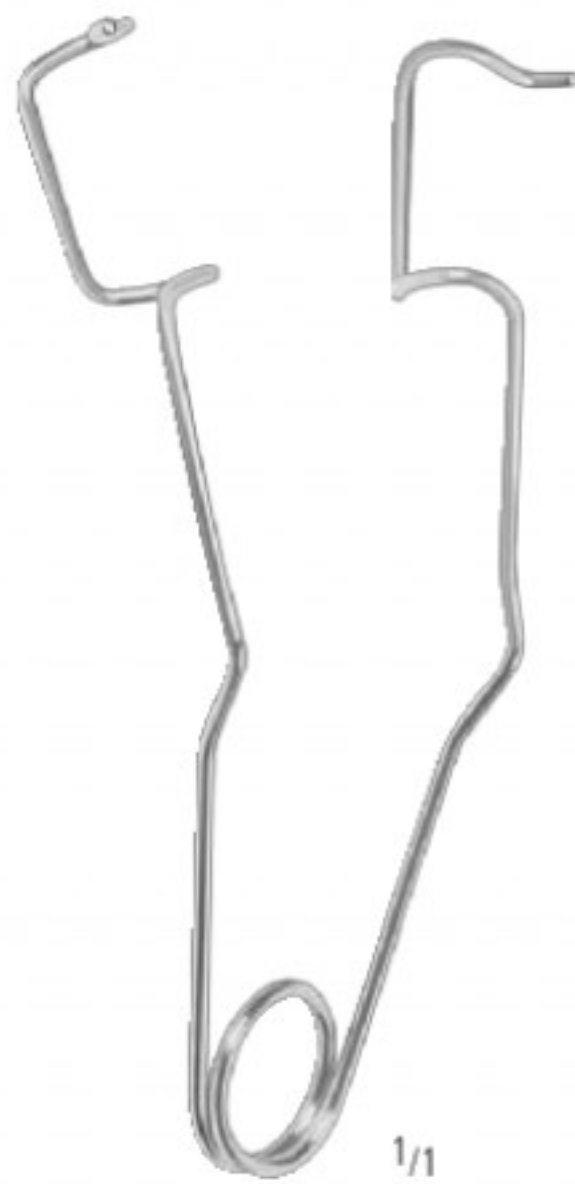

BOWMAN
KP 160/07
7,0 cm/2³/₄"

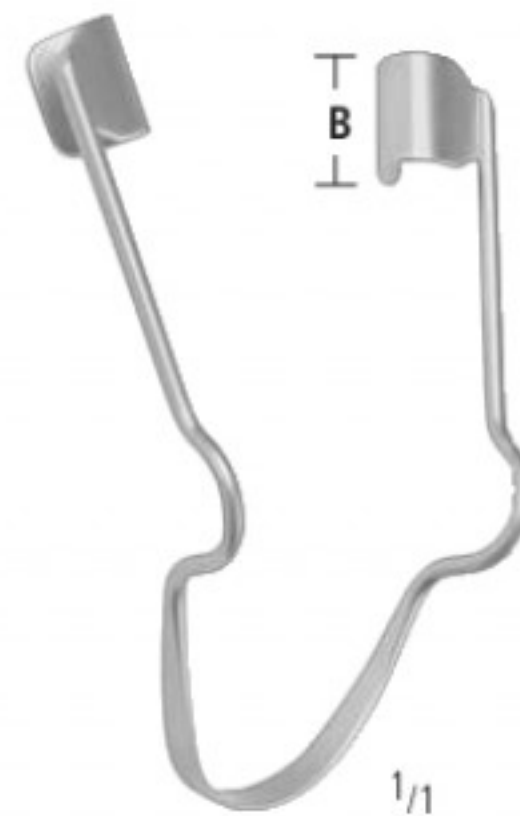

CORCELLE
KP 161/05
5,0 cm/ 2"
B = 8 mm



WILLIAMS
KP 162/09
9,0 cm/3¹/₂"
B = 14 mm

Lidsperrer
Eye Specula
Blefarostatos
Blépharostats
Blefarostati

AA

AB

AC

AD

AE

AK

AR

KA

KM

KO

KP

KYE

XR

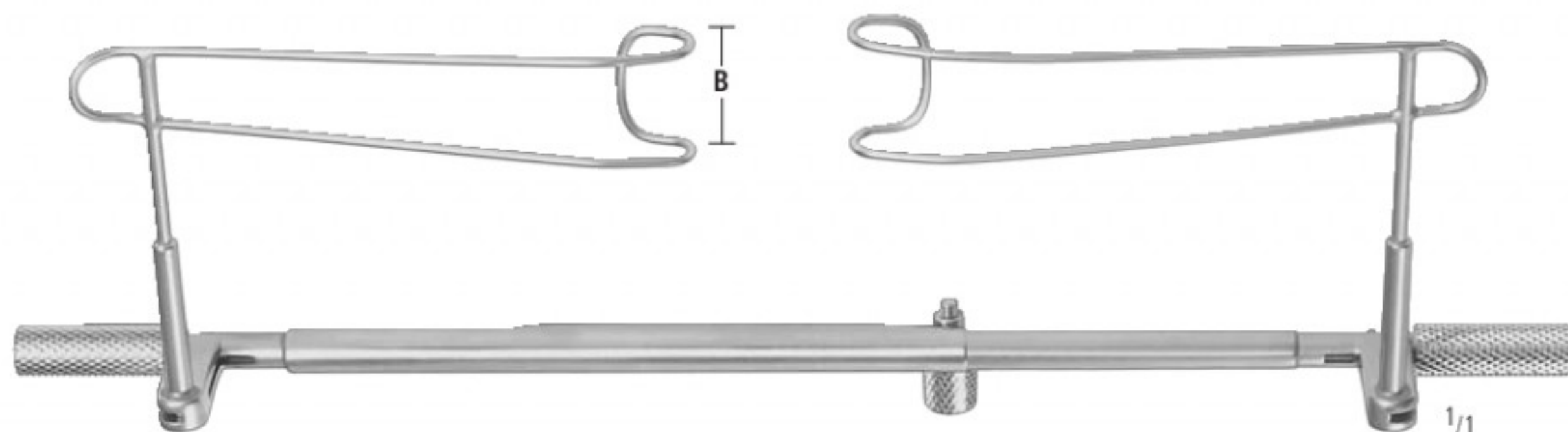

SCHOTT
15,0 cm/6"

Kind
Child
Niños
Enfants
Bambini

B
12 mm KP 170/12

Erwachsene
Adults
Adultos
Adultes
Adulti

B
15 mm KP 170/15



CASTROVIEJO
KP 175/09
9,0 cm/3¹/₂"
B = 16 mm



MAUMENEE-PARK
KP 176/09
8,5 cm/3¹/₄"



MAUMENEE-PARK
KP 177/09
8,5 cm/3¹/₄"

Lidsperrer
Eye Specula
Blefarostatos
Blépharostats
Blefarostati



PLEY
KP 185/07
6,5 cm/2 1/2"



LANCASTER
KP 186/08
8,0 cm/3 1/4"



LESTER-BURCH
KP 187/08
8,0 cm/3 1/4"



COOK

	B	
Kind	10 mm	KP 200/10
Child		4,0 cm/1 1/2"
Niños		
Enfants		
Bambini		
Erwachsene	15 mm	KP 200/15
Adults		5,0 cm/ 2"
Adultos		
Adultes		
Adulti		



SAUER

	B	
Kind	8 mm	KP 205/08
Child		3,0 cm/1 1/4"
Niños		
Enfants		
Bambini		

Lidsperrer
Eye Specula
Blefarostatos
Blépharostats
Blefarostati

AA

AB

AC

AD

AE

AK

AR

KA

KM

KO

KP

KYE

XR



V-förmig
V-shaped
forma V
forme V
forme V

LIEBERMAN
KP 210/01
8,0 cm/3¹/₄"
B = 15 mm



K-förmig
K-shaped
forma K
forme K
forme K

LIEBERMAN
KP 210/02
8,0 cm/3¹/₄"
B = 15 mm



LIEBERMAN
KP 211/08
8,0 cm/3¹/₄"
B = 15 mm



LIEBERMAN
KP 212/08
8,0 cm/3¹/₄"
B = 15 mm

Tränensackspreizer, Lidplatte
 Lacrimal Sac Retractors, Lid Plate
 Separadores para saco lacrimal, Placa para párpados
 Ecarteurs à sac lacrymal, Plaque à paupières
 Divaricatore per sacco lacrimale, Elevatori per palpebre



STEVENSON
 KP 230/08
 7,5 cm/3"



AGRICOLA
 KP 232/05
 4,5 cm/1³/₄"



JAEGER
 KP 248/11
 11,0 cm/4¹/₂"



JAFFE
 4,0 cm/1¹/₂"

Paar
 Pair
 Par
 Paire
 Paio

B
 Kind 10 mm KP 245/10
 Child
 Niños
 Enfants
 Bambini

B
 Erwachsene 15 mm KP 245/15
 Adults
 Adultos
 Adultes
 Adulti

Orbitalretraktoren und -spatel, Wundlöffel
 Orbital Retractors and Spatulas, Protector
 Separadores y espátulas orbitales, Protector
 Ecarteurs et spatules à orbite, Protecteur
 Divaricatori orbitale, Spatole per orbita, Protettore

AA

AB

AC

AD

AE

AK

AR

KA

KM

KO

KP

KYE

XR

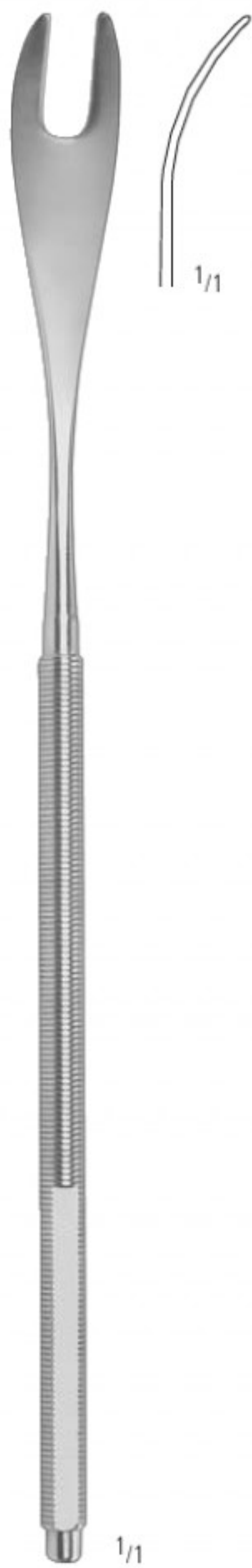

SCHEPENS
 KP 260/16
 15,5 cm/6¹/₄"

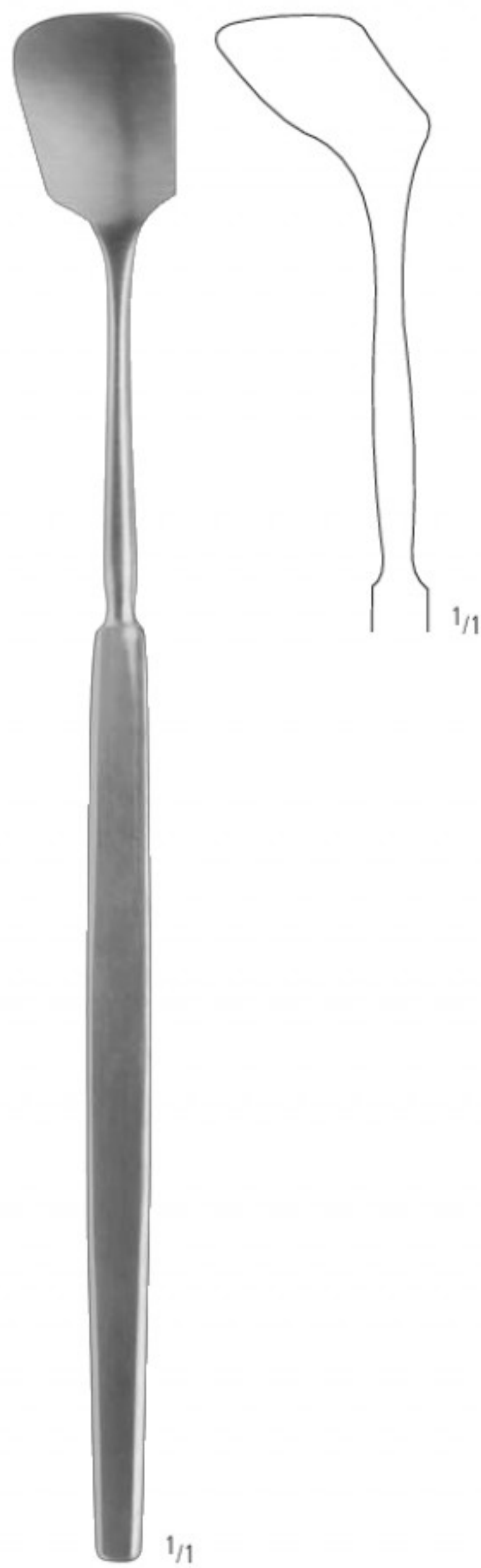

SAUTTER
 KP 261/15
 15,0 cm/6"



ARRUGA
 KP 262/13
 13,0 cm/5"

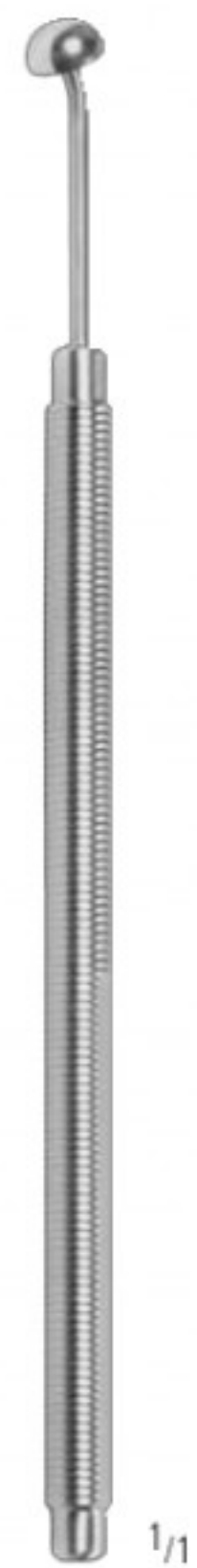

LASIK
 KP 270/10
 10,0 cm/4"

Depressor, Sklera Marker
 Depressors, Scleral Markers
 Depresores, Marcadores de esclerótica
 Dépresseurs, Marqueur scléral
 Depressore, Marcadori sclerali



SCHOCKET
 KP 280/14
 14,0 cm/5 1/2"



GASS
 KP 285/05
 4,5 cm/1 3/4"
 Ø 1,5 mm



SCHEPENS
 4,0 cm/1 1/2"

KP 290/08
 Fig. 8

klein
 small
 pequeño
 petit
 piccolo

KP 290/10
 Fig. 10

medium
 medium
 medio
 moyen
 medio

KP 290/12
 Fig. 12

groß
 large
 grande
 grand
 grande

Hornhautmesser und -schaber, Diszisionmesser
 Corneal Knives and Scarifiers, Discission Knives
 Cuchillos y Rescadores para la córnea, Cuchillos para discisión
 Kératomes, Grattoirs cornéés, Couteaux à discision
 Coltelli per cornea, Raschiatoi corneali, Coltelli per discissione

AA

AB

AC

AD

AE

AK

AR

KA

KM

KO

KP

KYE

XR



SATO
 KP 300/12
 12,0 cm/ 4³/₄"
 5 mm



GILL
 KP 302/13
 12,5 cm/4¹/₂"
 3 mm

gerade
 straight
 recto
 droit
 rette



KP 303/12
 11,5 cm/ 5"
 3 mm

gebogen
 curved
 curvas
 courbes
 curve



TOOK
 KP 305/11
 11,0 cm/ 4¹/₄"
 3 x 18 mm

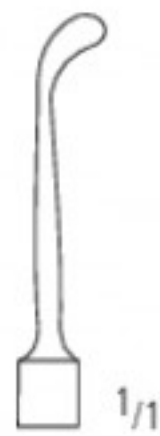

KUHNT
 KP 309/11
 11,0 cm/ 4¹/₄"
 3 x 5 mm



ZIEGLER
 11,0 cm/ 4¹/₄"
 KP 310/03
 3 mm



KP 310/05
 5 mm



WHEELER
 KP 312/11
 11,0 cm/ 4¹/₄"
 1 x 18 mm

Star-, Sklera-, Goniotomiemesser
 Cataract, Sclera and Goniotomy Knives
 Cuchillos para catarata, para esclerótica, para goniotomía
 Couteaux à cataracte, pour la sclère, à goniotomie
 Coltelli per cataratta, sclerali e per goniotomia



1/1

GRAEFE



1/1

KP 320/20
 12,0 cm/ 4³/₄"
 20 mm



1/1

KP 320/25
 12,5 cm/ 5"
 25 mm

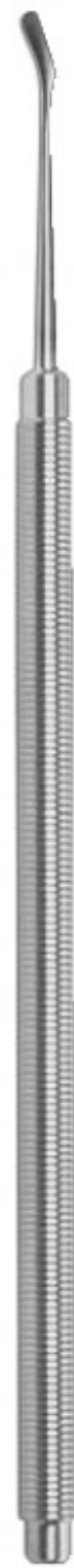

1/1

BONN



1/1

KP 325/05
 12,5 cm/ 5"
 5 mm



1/1

KP 325/06
 12,5 cm/ 5"
 6 mm

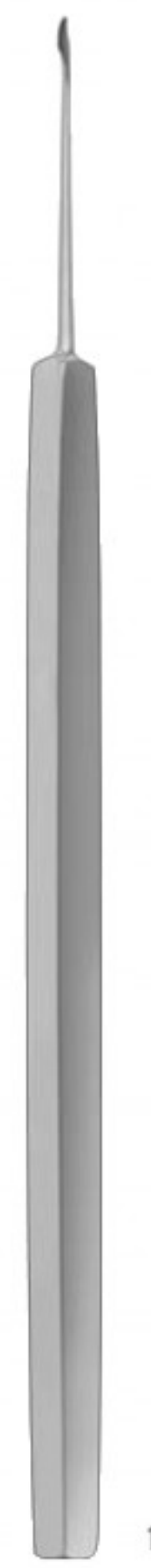

1/1

BARKAN
 KP 330/12
 12,0 cm/ 4³/₄"
 2 mm



1/1

Luftlanze, Keratoplastikmesser, Zystotome
 Keratome, Keratoplasty Knives, Cystotomes
 Querátomo, Cuchillos para queratoplástica, Quistótomos
 Couteaux lancéolaires, Couteaux pour kératoplastie, Cystotomes
 Coltelli lanceolari, Coltelli per cheratoplastica, Cistotomi

AA

AB

AC

AD

AE

AK

AR

KA

KM

KO

KP

KYE

XR

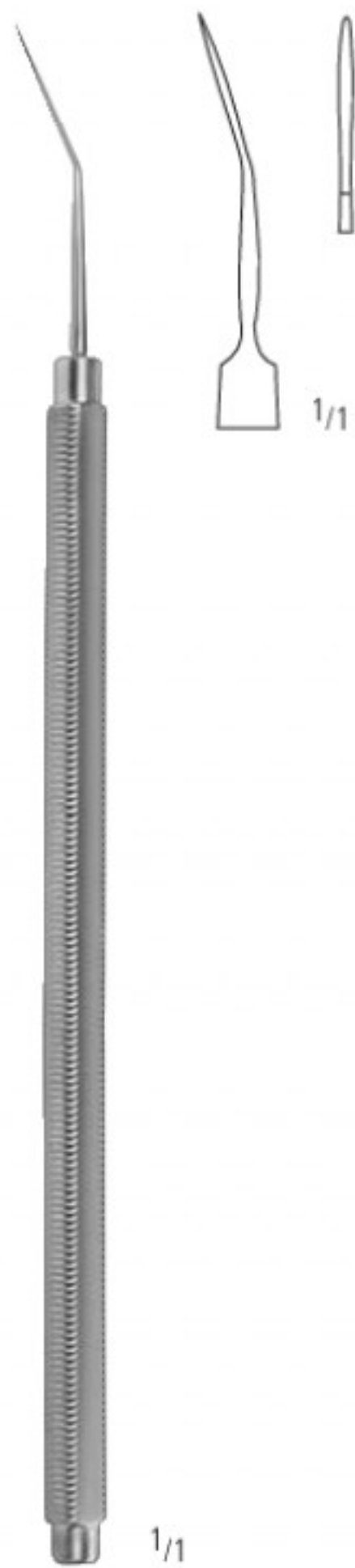

MOD. HAMBURG
 KP 335/12
 12,0 cm/ 4³/₄"

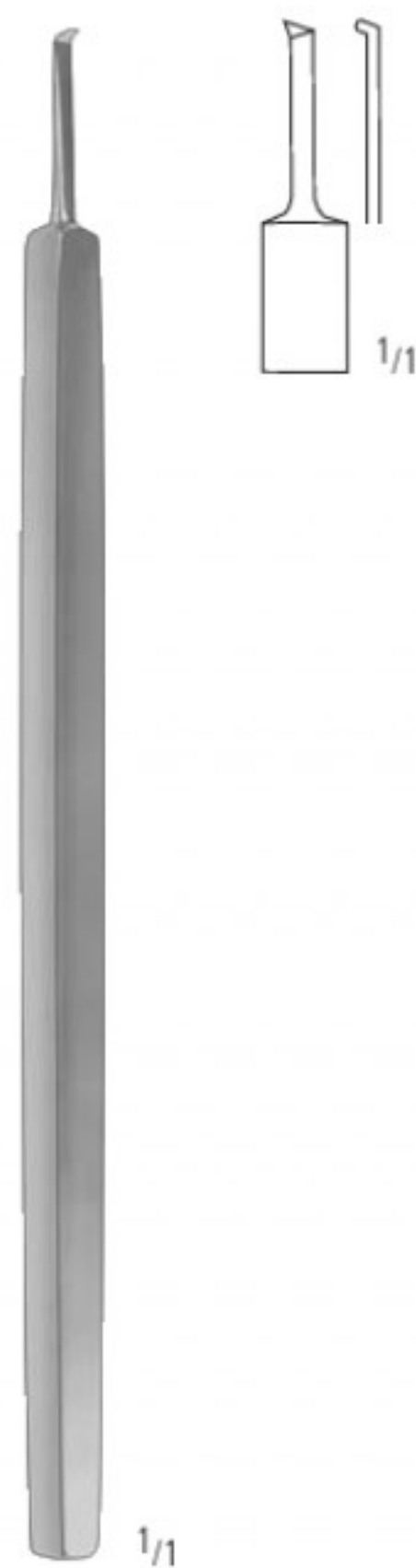

PAUFIQUE
 KP 340/11
 10,5 cm/ 4¹/₄"



GRAEFE
 KP 346/13
 12,5 cm/ 5"

biegsam
 malleable
 maleable
 malleable
 malleabile

Fremdkörpernadeln, -hohlmeißel und -meißel
 Foreign Body Needles, Gouges and Spuds
 Agujas, Gubias y Cinceles para cuerpos extraños
 Aiguilles, Gouges et Ciseaux-burins à corps étrangers
 Aghi, Sgorbie e Scalpelli per corpi estranei



KP 350/12

umschraubbar
 reversible
 reversible
 révisible
 rivoltabile



KP 350/13

umschraubbar
 reversible
 reversible
 révisible
 rivoltabile



1/1



KP 351/01



KP 351/02



KP 351/03

Fremdkörpernadeln und -meißel
 Foreign Body Needles and Spuds
 Agujas y Cinceles para cuerpos extraños
 Aiguilles et Ciseaux-burins à corps étrangers
 Aghi e Scalpelli per corpi estranei

AA

AB

AC

AD

AE

AK

AR

KA

KM

KO

KP

KYE

XR



KP 354/12
 12,0 cm/ 4³/₄"



KP 355/12
 12,0 cm/ 4³/₄"



DAVIS
 KP 360/12
 12,0 cm/ 4³/₄"

scharf, rund
 sharp, round
 afilado, redondo
 coupant, rond
 tagliente, rotondo

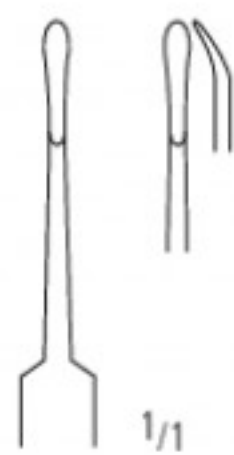

ELLIS
 KP 361/12
 11,5 cm/4¹/₂"

gebogen, rund
 curved, round
 curvado, redondo
 courbe, rond
 curvo, rotondo



FRANCIS
 KP 363/12
 12,0 cm/ 4³/₄"



GOLF-CLUB
 KP 364/12
 11,5 cm/4¹/₂"

Fremdkörpernadeln, -hohlmeißeln und -meißeln, Augenmagnet mit Fremdkörperschlinge
 Foreign Body Needles, Gouges and Spuds, Magnetic Eye Probe with Foreign Body Loop
 Agujas, Gubias y Cinceles para cuerpos extraños, Imán oftálmico con asa para cuerpos extraños
 Aiguilles, Gouges et Ciseaux-burins à corps étrangers, Aimant oculaire avec anse pour corps étrangers
 Aghi, Sgorbie e Scalpelli per corpi estranei, Calamita per occhi con ansa per corpi estranei

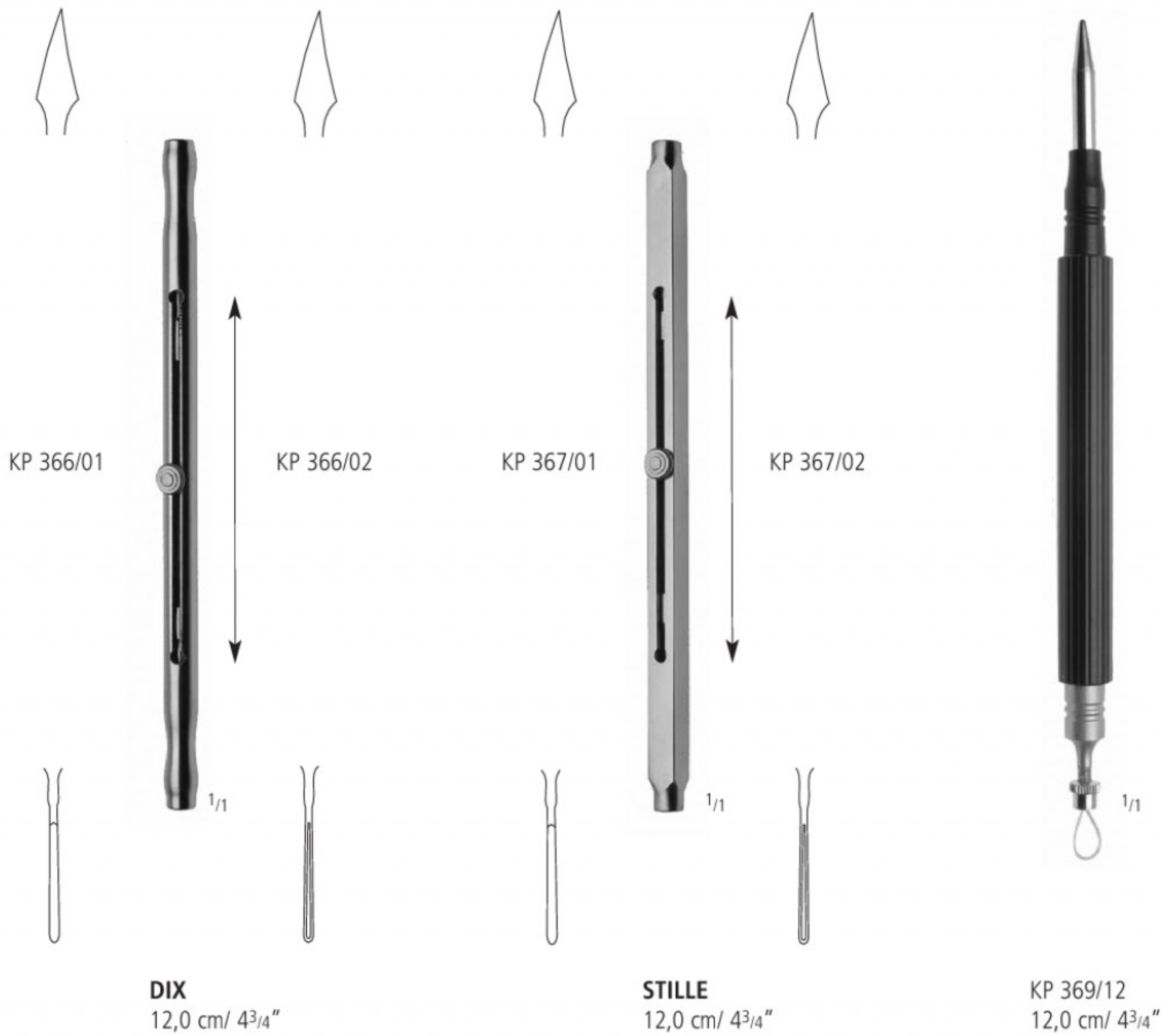

Diamantmesser
 Diamond Knives
 Bisturís de diamante
 Couteaux de diamant
 Coltelli di diamanti

AA

AB

AC

AD

AE

AK

AR

KA

KM

KO

KP

KYE

XR

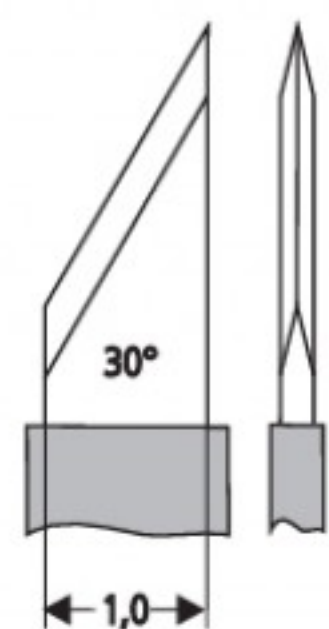

KP 370/01

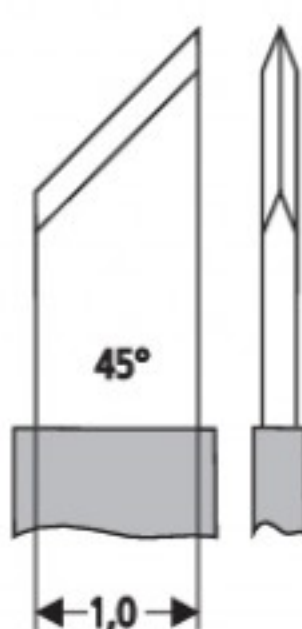

KP 370/02

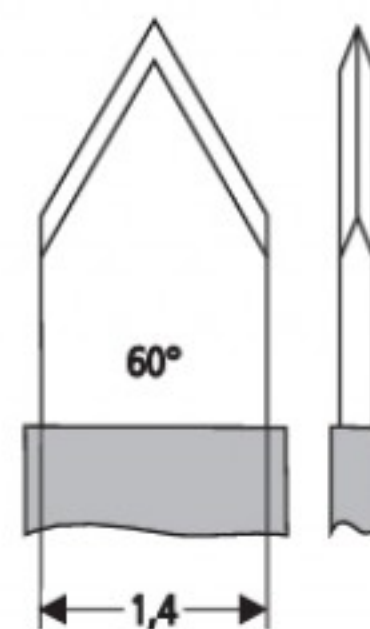

KP 370/03

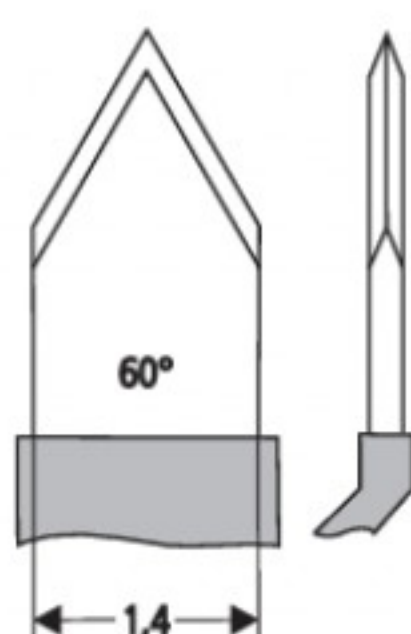

KP 370/04

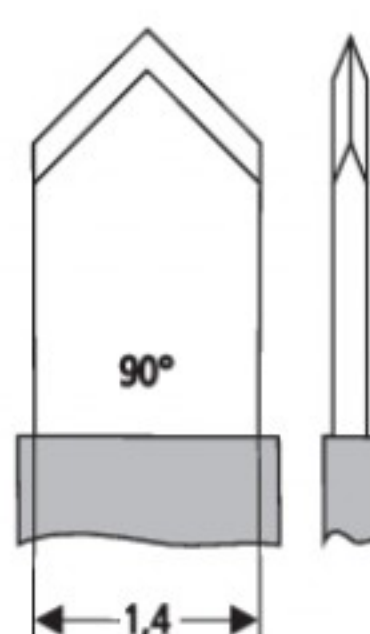

KP 370/05

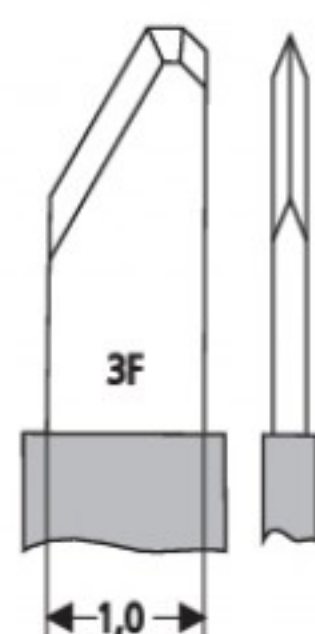

KP 371/01

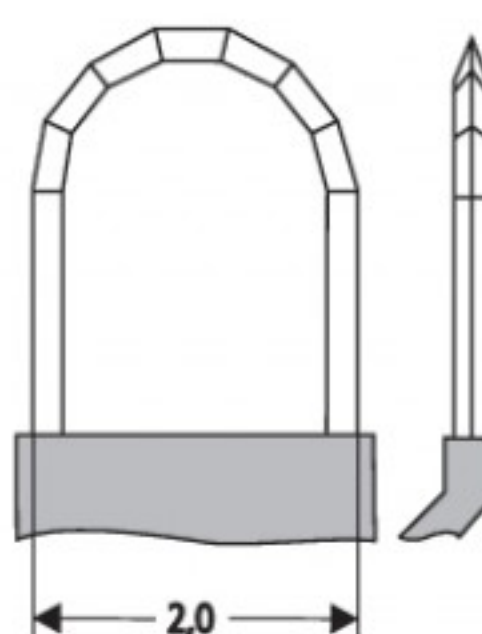

KP 371/02



1/1

Diamantmesser
 Diamond Knives
 Bisturís de diamante
 Couteaux de diamant
 Coltelli di diamanti

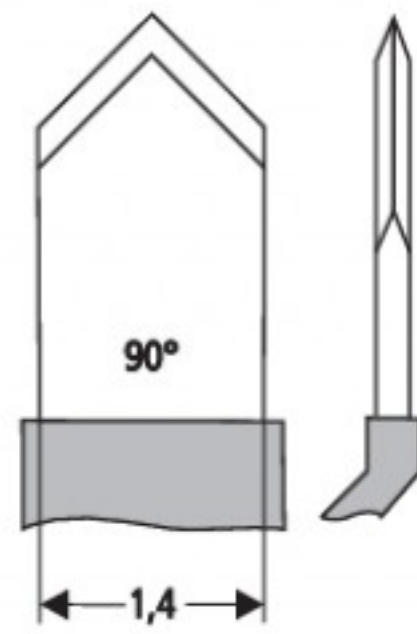

KP 373/01

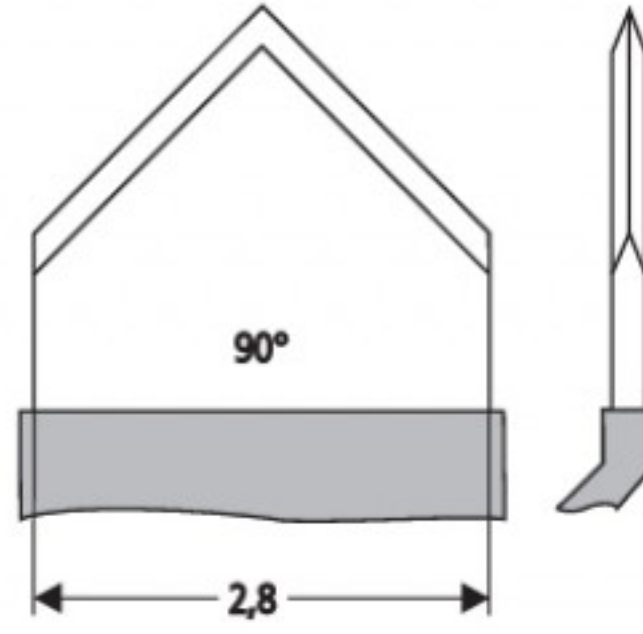

KP 373/02

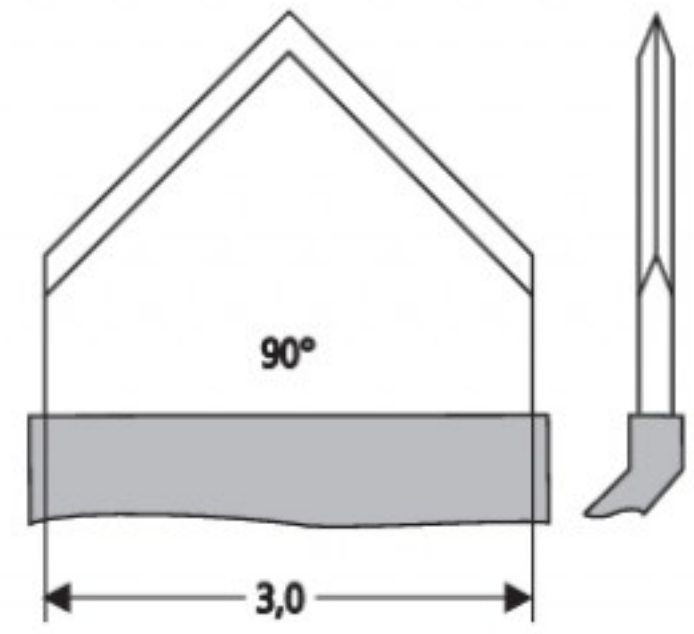

KP 373/03

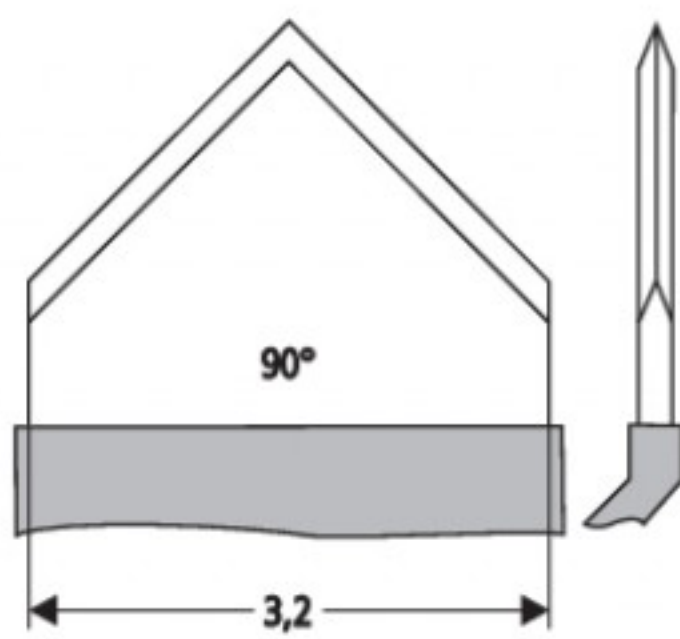

KP 373/04

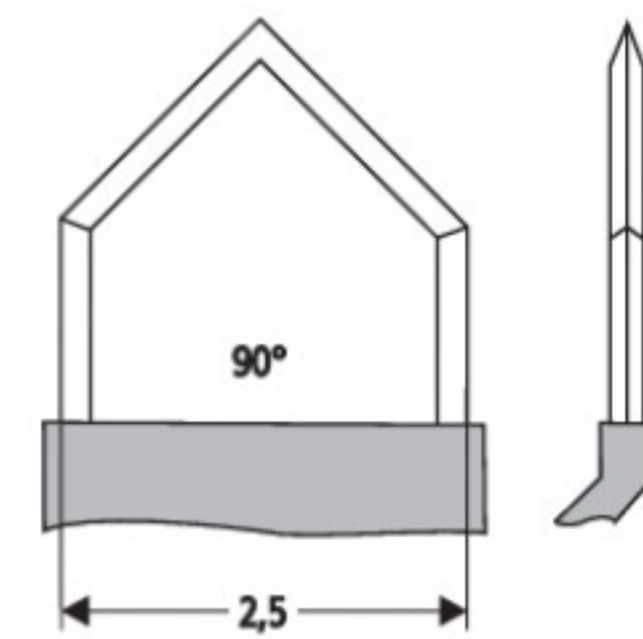

KP 373/05

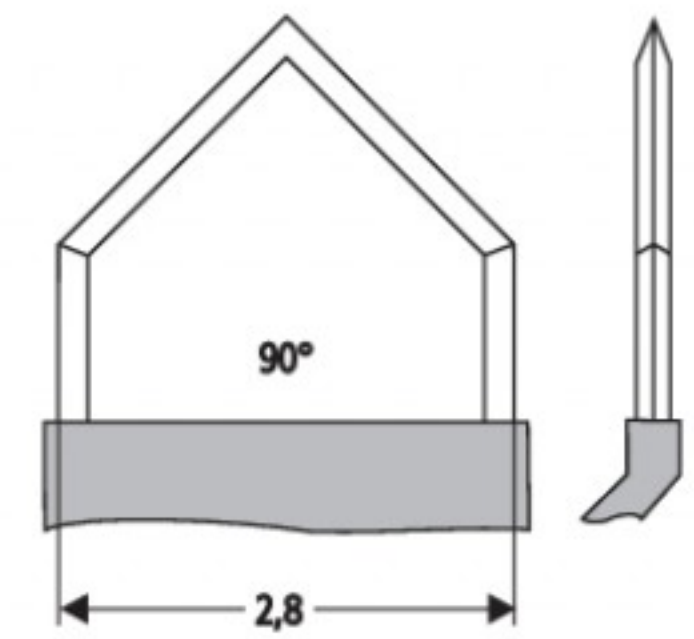

KP 373/06

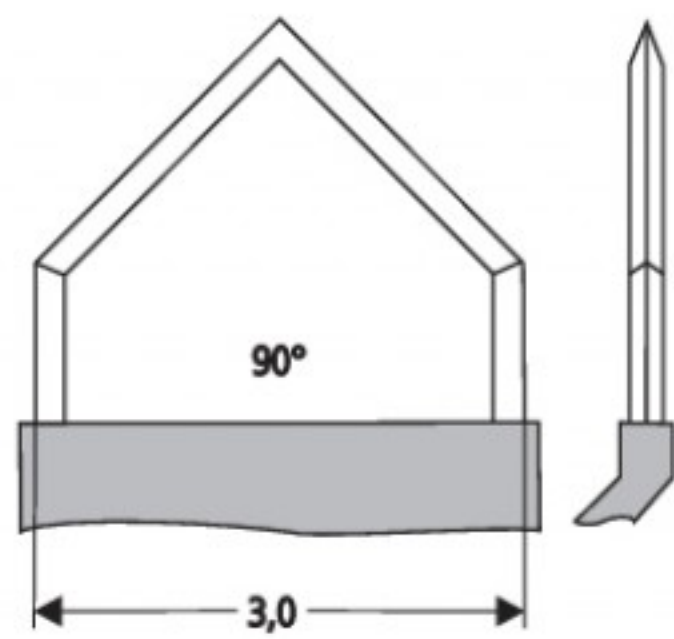

KP 373/07

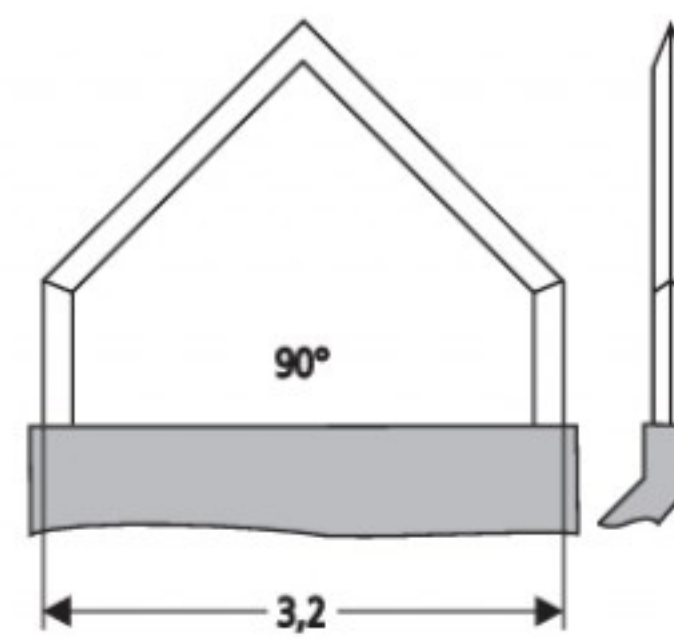

KP 373/08



1/1

Diamantmesser
 Diamond Knives
 Bisturís de diamante
 Couteaux de diamant
 Coltelli di diamanti

AA

AB

AC

AD

AE

AK

AR

KA

KM

KO

KP

KYE

XR



1/1

mit Mikrometer
 with micrometer
 con micrómetro
 avec micromètre
 con micrometro

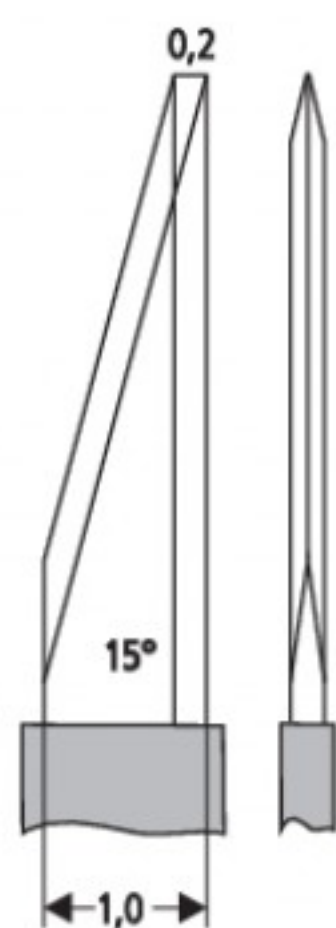

KP 375/01

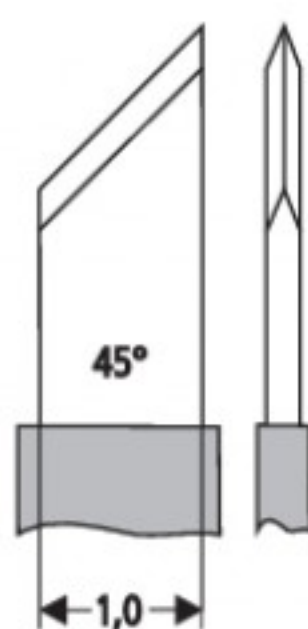

KP 375/02

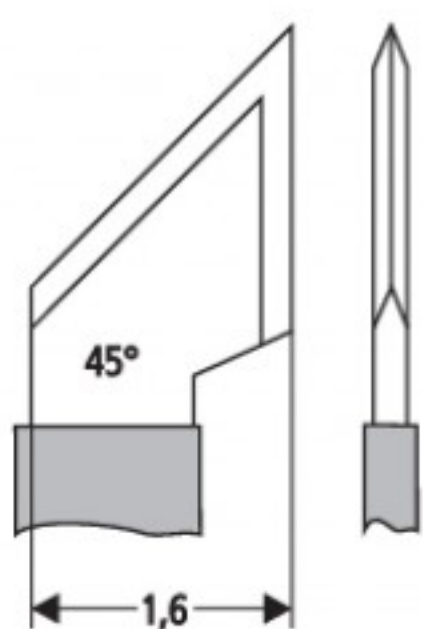

KP 375/03



1/1

7 Stufen:
 7 steps:
 7 escalones:
 7 étages:
 7 gradi:

0 / 0,3 / 0,4 / 0,5 / 0,6 / 0,8 / 1,0 / 2,5 mm

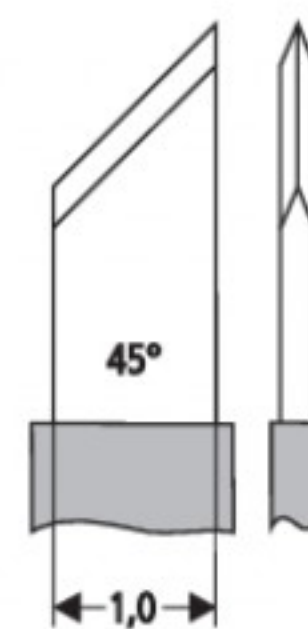

KP 376/01

Vitrektomiescheren
 Vitrectomy Scissors
 Tijeras de vitrectomía
 Ciseaux pour vitrectomie
 Forbici per vitrectomia



ohne Spülung
 without irrigation
 sin irrigaciòn
 sans irrigation
 senza irrigazione

mit Spülung
 with irrigation
 con irrigaciòn
 avec irrigation
 con irrigazione



KP 390/00
 0°

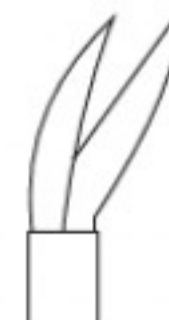

KP 390/30
 30°



60° KP 390/60
 90° KP 390/90

90°

Vitrektomiefasszangen
 Vitrectomy Grasping Forceps
 Pinzas de vitrectomía
 Pincas pour vitrectomie
 Pinze per vitrectomia

AA

AB

AC

AD

AE

AK

AR

KA

KM

KO

KP

KYE

XR



KP 394/00



KP 395/01



KP 395/02



KP 395/03



0,30 mm KP 396/30
 0,44 mm KP 396/44



KP 397/45
 45°

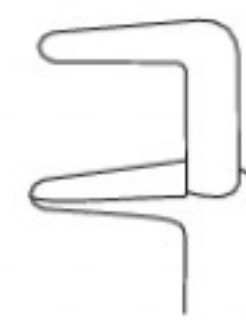

KP 397/90
 90°

Exenterations- und Enukleationslöffel
 Exenteration- and Enucleation Spoons
 Cucharas para exenteración y para enucleación
 Cuillers à éviscération et à énucléation
 Cucchiari da enucleazione



1/1

BUNGE



1/1

KP 400/01
14,0 cm/5 1/2"



1/1

KP 400/02
14,0 cm/5 1/2"



1/1

WELLS



1/1

KP 405/14
14,0 cm/5 1/2"

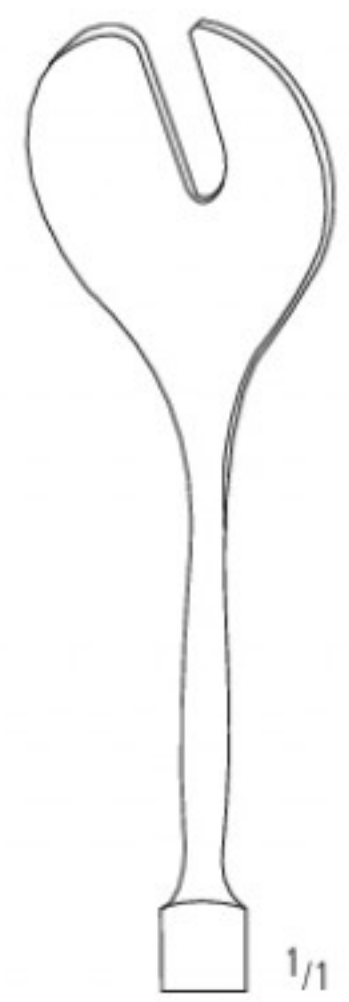

1/1

KP 405/15
15,0 cm/6"

Starlöffel, Chalazionlöffel
 Corneal Button Transfer Spoon, Chalazion Curettes
 Cucharas para transferir la córnea, Cucharillas para chalazión
 Cuillers pour transférer la cornée, Cuillers à chalazion
 Anse per cristallino, Cucchiari per calazio

AA

AB

AC

AD

AE

AK

AR

KA

KM

KO

KP

KYE

XR



KNAPP
 KP 410/14
 13,5 cm/5¹/₄"

für Hornhauttransfer
 for corneal button transfer
 para transferir la córnea
 pour transférer la cornée
 per transferire la cornea

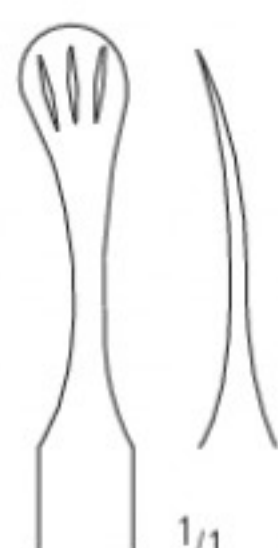

CASTROVIEJO
 KP 411/12
 12,0 cm/4³/₄"



MEYHOEFER
 13,0 cm/5"



KP 415/10
 Ø 1,0 mm



KP 415/15
 Ø 1,5 mm



KP 415/18
 Ø 1,8 mm



KP 415/20
 Ø 2,0 mm



KP 415/25
 Ø 2,5 mm



KP 415/30
 Ø 3,0 mm



KP 415/35
 Ø 3,5 mm

Chalazionlöffel, Starlöffel, Starschlingen
 Chalazion Curettes, Cataract Spoons, Lens Scoops
 Cucharillas para chalazión y para catarata, Asas para catarata
 Cuillers à chalazion et à cataracte, Anses à cataracte
 Cucchiai per calazio, Cucchiai per cataratta, Anse per cataratta

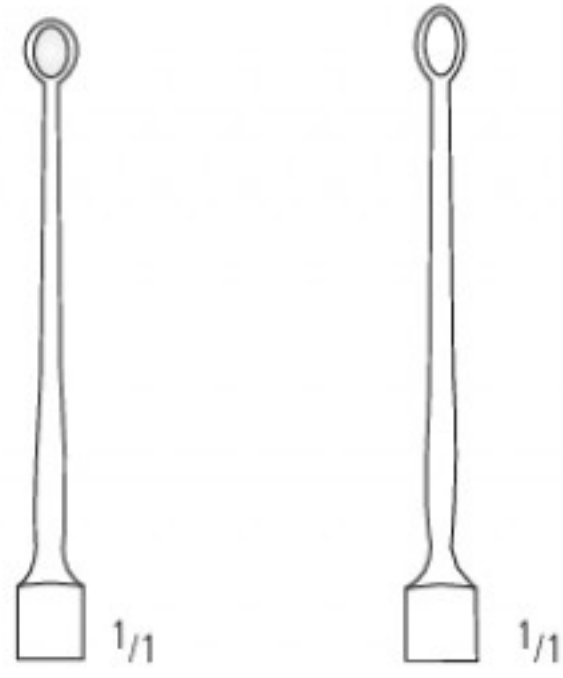

HEBRA
 13,0 cm/5"
 KP 417/20 KP 417/25
 Ø 2,0 mm Ø 2,5 mm



GRAEFE
 KP 425/14
 13,5 cm/5¹/₄"



DAVIEL
 KP 427/12
 12,0 cm/4³/₄"
 3 x 14 mm



SNELLEN
 KP 440/13
 13,0 cm/5"



ARLT
 KP 442/13
 13,0 cm/5"



LEWIS
 13,0 cm/5"
 KP 443/01 KP 443/02
 4,0 mm 4,7 mm



NEW ORLEANS
 KP 450/13
 13,0 cm/5"

Positionsspatel, Linsenkernelspatel
 Lens Spatulas, Nucleus Spatulas
 Espátulas para manipular, Espátulas para núcleo cristalino
 Spatules pour manipuler, Spatules pour noyau
 Spatole per manipolare, Spatole per nucleo cristallino

AA

AB

AC

AD

AE

AK

AR

KA

KM

KO

KP

KYE

XR

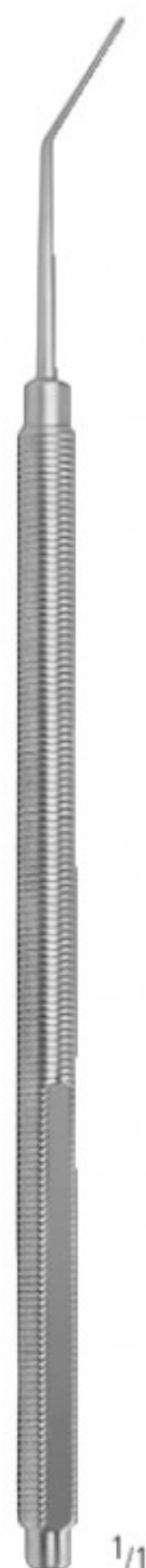

JAFFE
 KP 470/12
 12,0 cm/ 4³/₄"
 0,5 mm

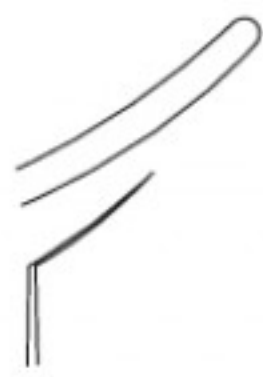

OBSTBAUM
 KP 471/12
 12,0 cm/ 4³/₄"
 0,25 mm



HIRSCHMANN
 KP 472/13
 12,5 cm/5"



MOD. DORTMUND
 KP 478/12
 12,0 cm/ 4³/₄"
 0,6 x 12 mm



KNOLLE
 KP 480/13
 12,5 cm/5"

TITANIUM

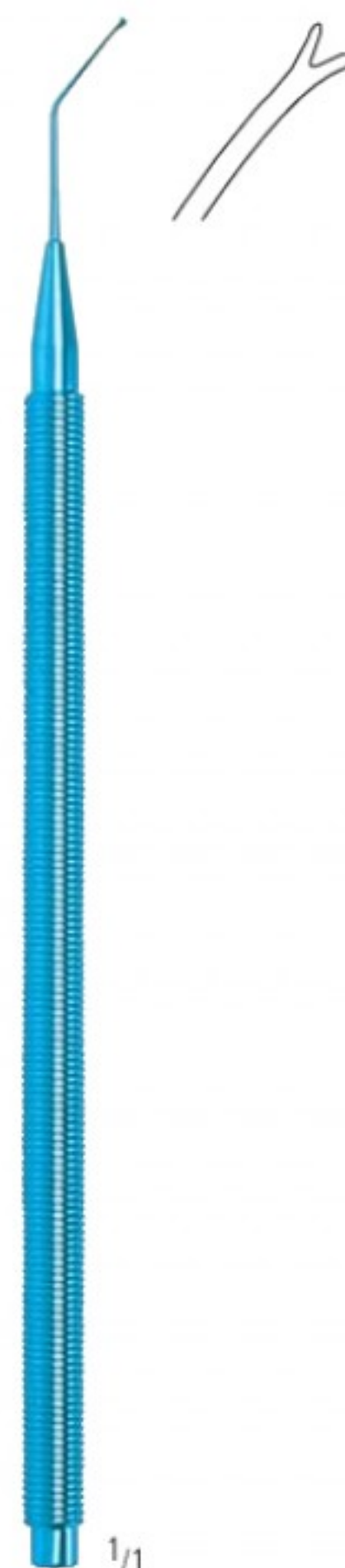

LIPPMAN
 KP 481/12
 12,0 cm/ 4³/₄"

Zyklodialysespatel
 Cyclodialysis Spatulas
 Espátulas para ciclodiálisis
 Spatules à cyclodialyse
 Spatole per ciclodialisi

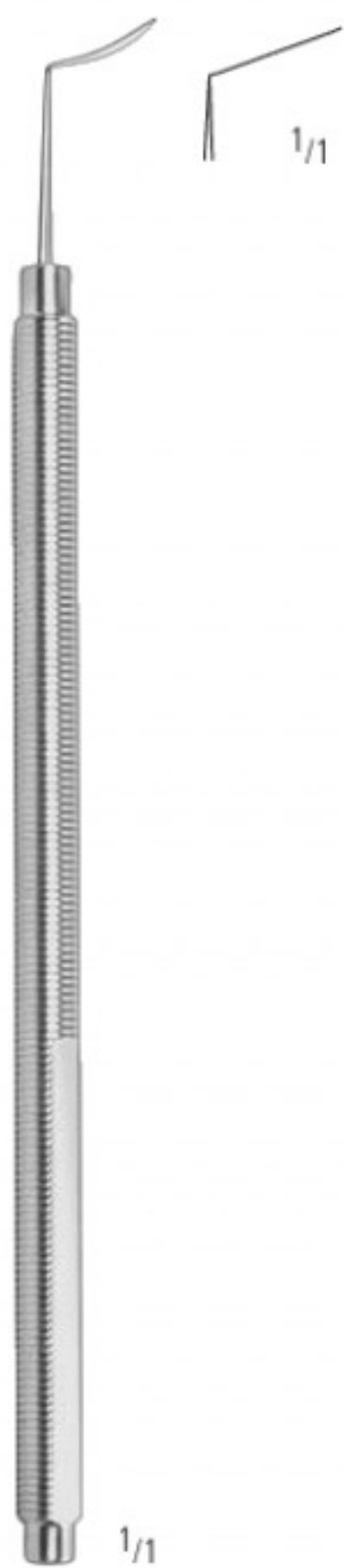

CASTROVIEJO-BARRAQUER
 KP 485/11
 11,0 cm/4¹/₂"
 0,5 x 10 mm



CASTROVIEJO
 KP 487/14
 13,5 cm/5¹/₄"
 0,5 x 10/16 mm

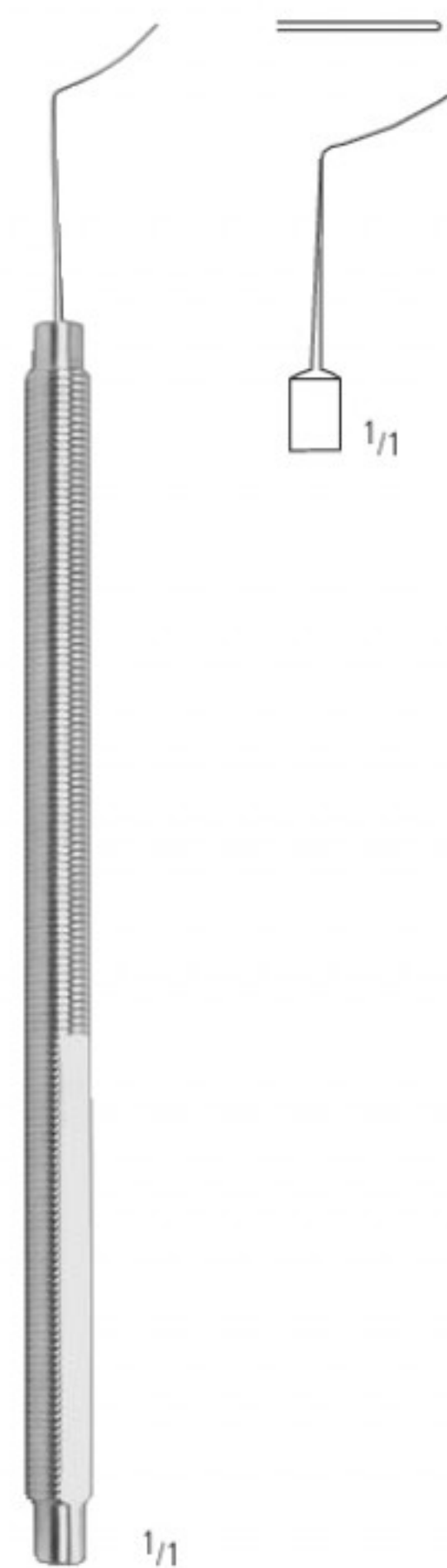

BARRAQUER-FINO
 KP 489/12
 11,5 cm/4¹/₂"
 0,25 x 12 mm

Irisspatel
Iris Spatulas
Espátulas para iris
Spatules à iris
Spatole per l'iride

AA

AB

AC

AD

TITANIUM

AE

AK

AR

KA

KM

KO

KP

KYE

XR



biegsam
malleable
maleable
malléable
malleabile

WECKER
KP 495/13
13,0 cm/5"
2 mm

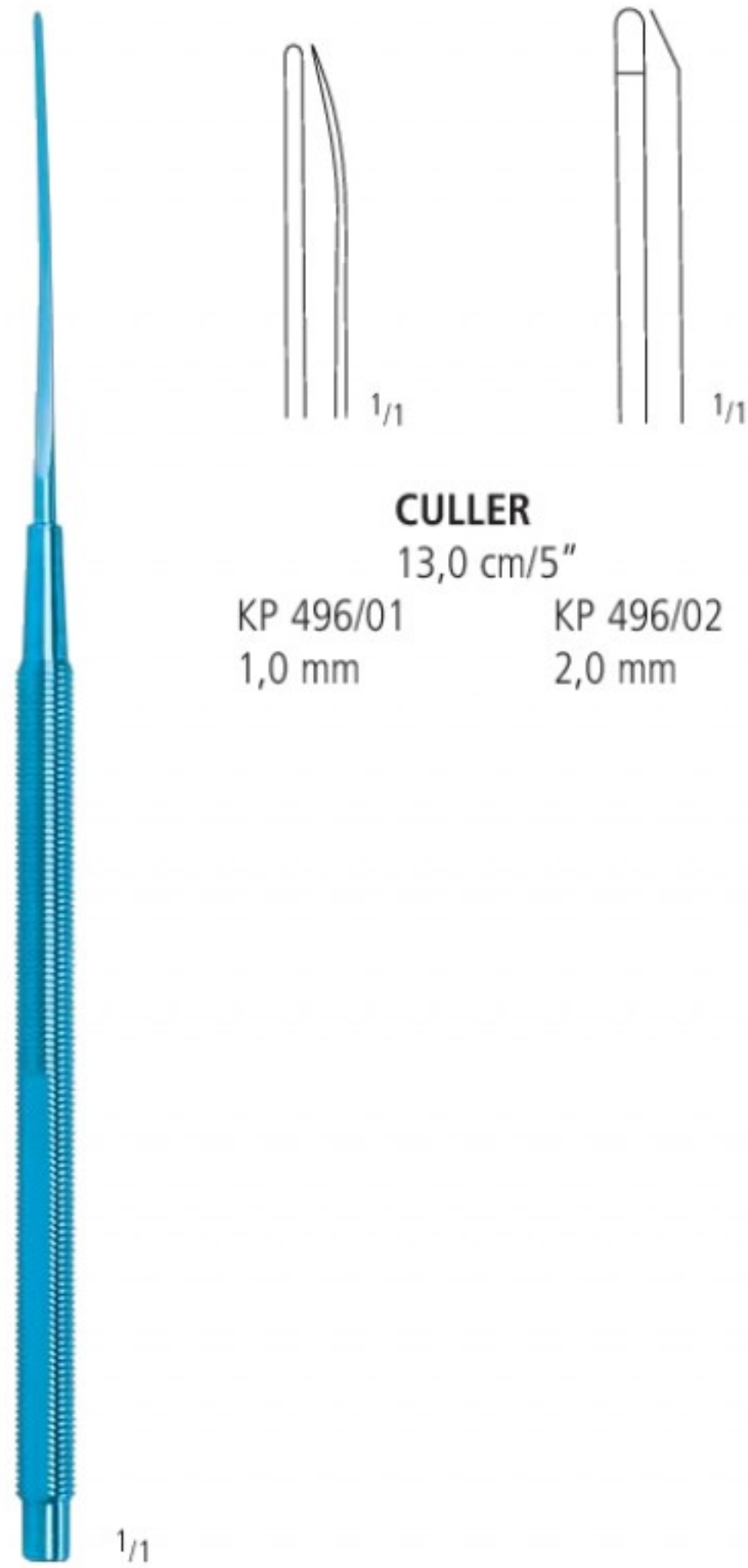

CULLER
13,0 cm/5"
KP 496/01 KP 496/02
1,0 mm 2,0 mm

Markierinstrumente optisches Zentrum, Radial- und Axialmarkierinstrumente
 Optical Zone Markers, Radial and Axis Markers
 Marcadores para centro óptico, Marcadores radiales y axiales
 Marqueurs pour centre optique, Marqueurs radiales et axiales
 Marcatori ottici, Marcatori radiali e assiali

TITANIUM

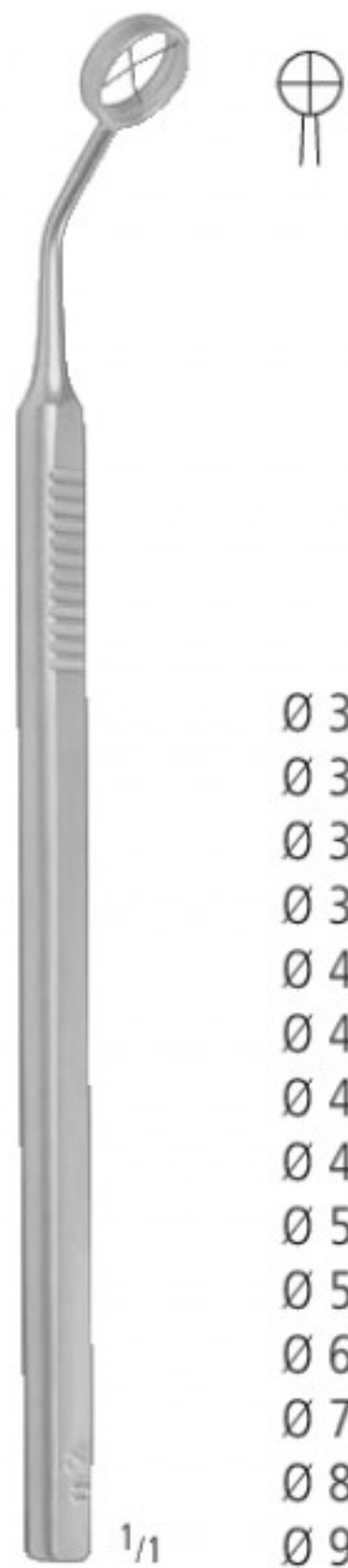

- Ø 3,00 mm KP 500/30
- Ø 3,25 mm KP 500/32
- Ø 3,50 mm KP 500/35
- Ø 3,75 mm KP 500/37
- Ø 4,00 mm KP 500/40
- Ø 4,25 mm KP 500/42
- Ø 4,50 mm KP 500/45
- Ø 4,75 mm KP 500/47
- Ø 5,00 mm KP 500/50
- Ø 5,50 mm KP 500/55
- Ø 6,00 mm KP 500/60
- Ø 7,00 mm KP 500/70
- Ø 8,00 mm KP 500/80
- Ø 9,00 mm KP 500/90

HOFFER
10,0 cm/4"

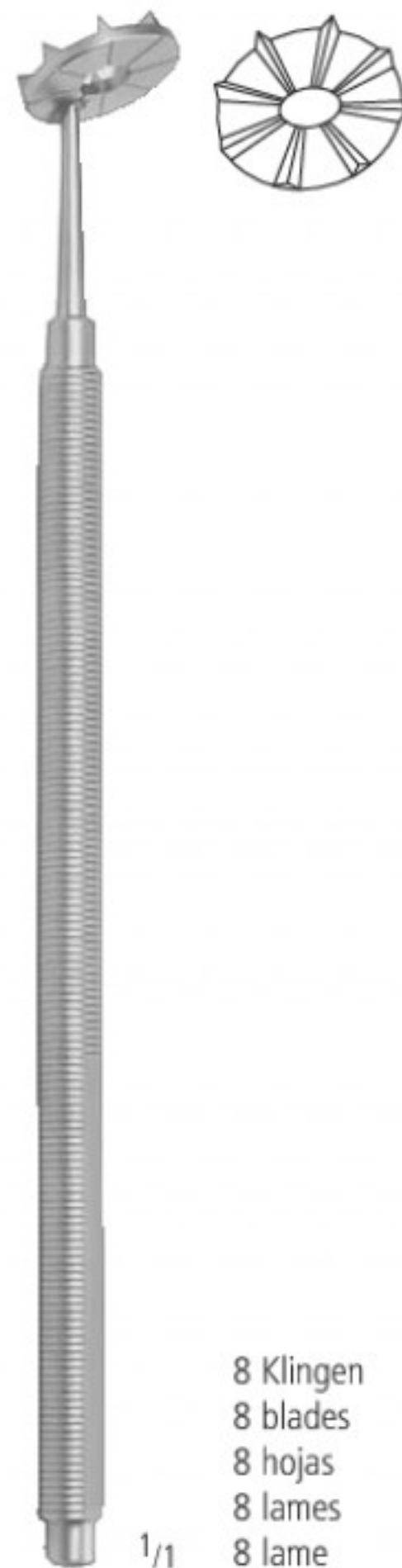

- 8 Klingen
- 8 blades
- 8 hojas
- 8 lames
- 8 lame

ANIS
KP 505/12
12,0 cm/4³/₄"
Ø 4 mm/12,5 mm

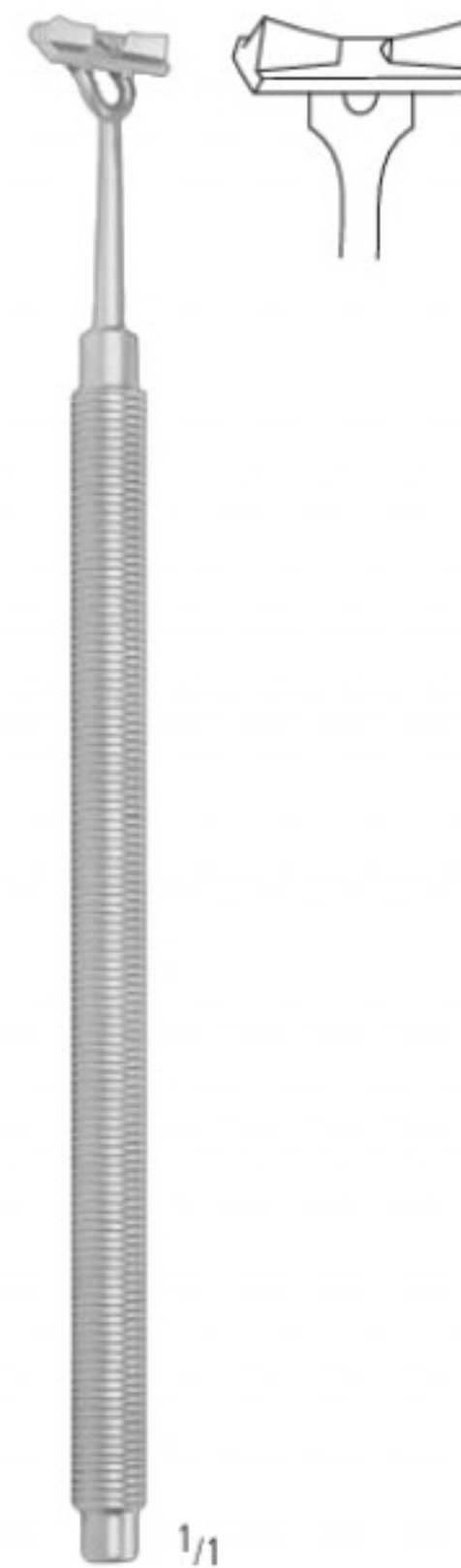

BORES
KP 508/10
10,0 cm/4"

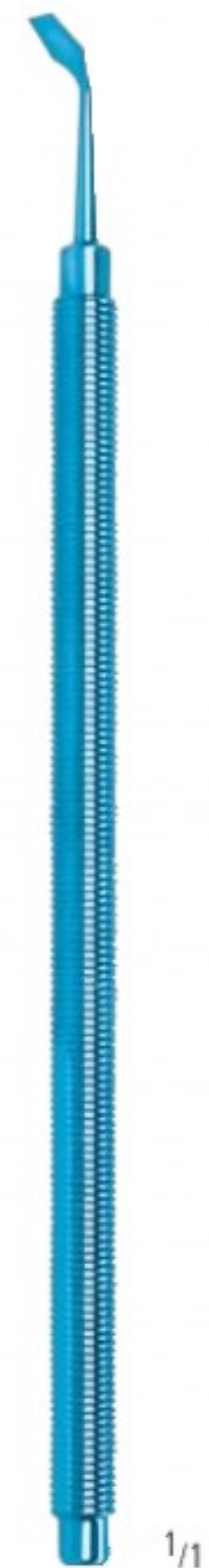

GRANDON
KP 510/11
11,0 cm/4¹/₂"
3 mm

Hornhautmarkierinstrumente
 Corneal Markers
 Marcadores corneales
 Marqueurs cornéens
 Marcatori corneali

AA

AB

AC

AD

AE

AK

AR

KA

KM

KO

KP

KYE

XR

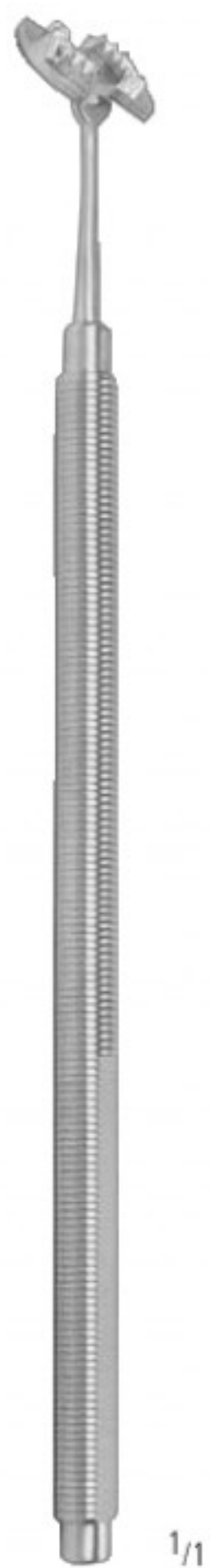

1/1

LINDSTROM
 KP 515/12
 12,0 cm/4³/₄"
 7 mm

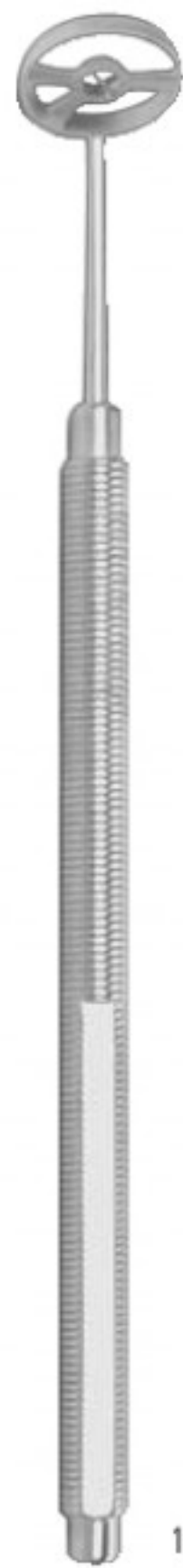

1/1

LU
 KP 516/11
 10,5 cm/4¹/₄"
 Ø 8,5 mm



1/1

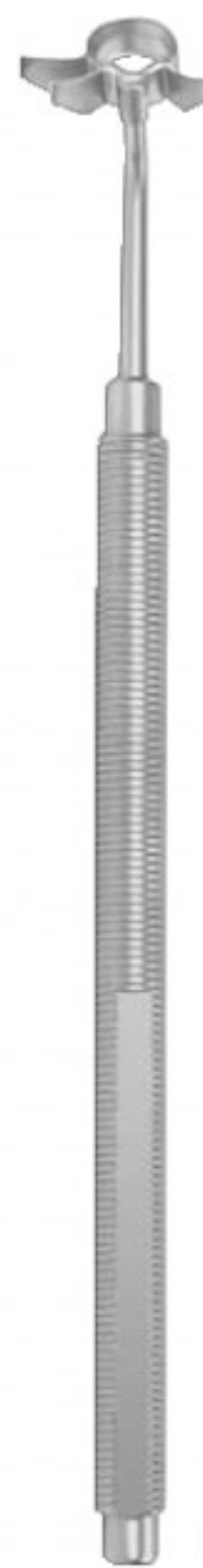

1/1

KP 518/10
 10,0 cm/4"

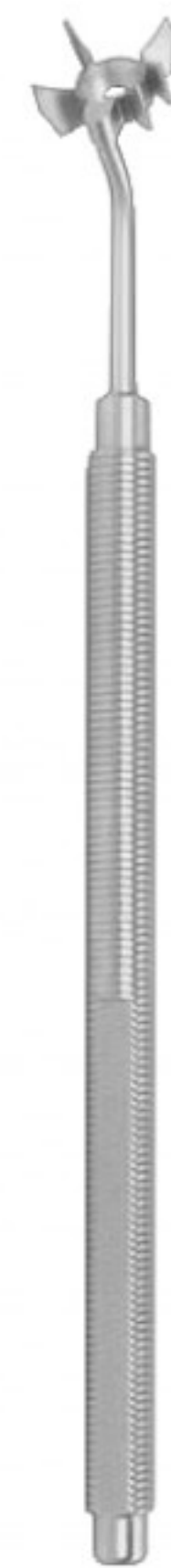

1/1

KP 519/10
 10,0 cm/4"
 Ø 5 + 11 mm



1/1

4+1 Klingen
 4+1 blades
 4+1 hojas
 4+1 lames
 4+1 lame

Hornhaut-, Limbus Inzisions-, Nahtplatzierungsmarkierinstrumente
 Corneal Markers, Limbal Incision Rulers, Suture Placement Markers
 Marcadores corneales, para incisión limbal y para suturas
 Marqueurs pour kéroplastie, pour incision limbique et à sutures
 Marcatori corneali, per incisione in limbo e per sutura

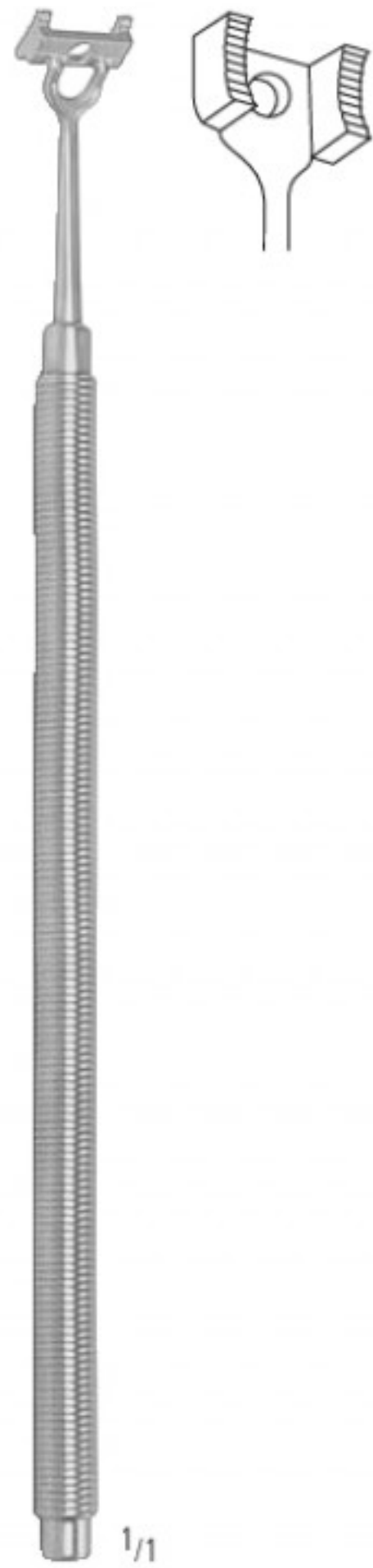

THORNTON
 KP 523/12
 12,0 cm/4³/₄"
 6-8 mm / 0,5-5,0 mm

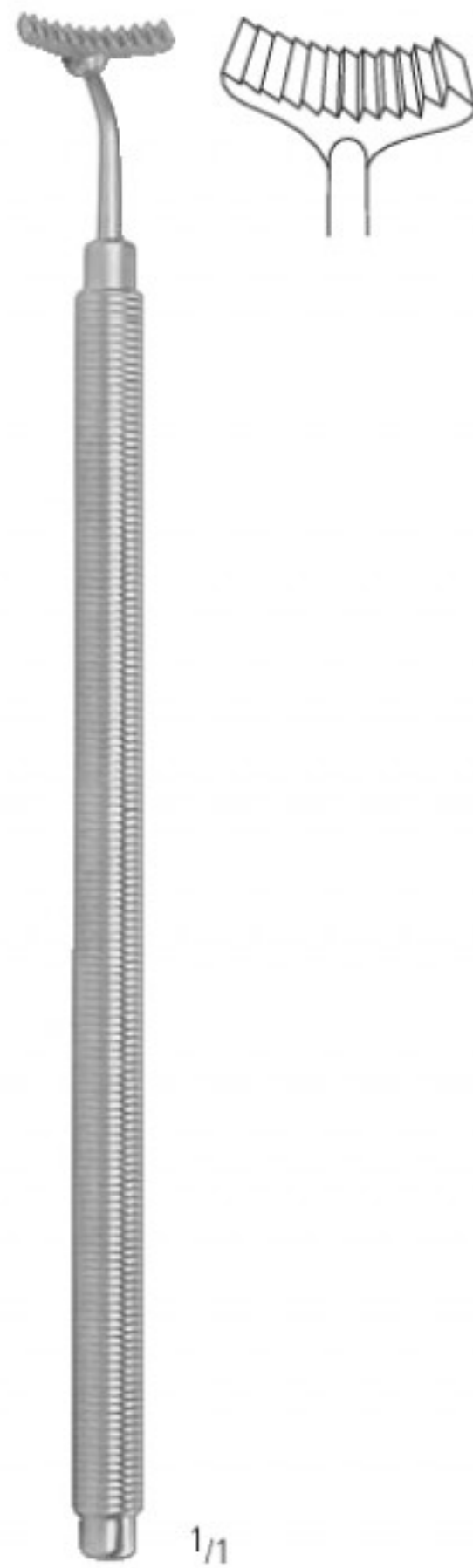

THORNTON
 KP 530/11
 11,0 cm/4¹/₂"
 1-10 mm



ANIS
 KP 535/12
 12,0 cm/4³/₄"



GONNIN
 KP 540/13
 13,0 cm/5"
 11-23 mm / 1 mm

Tonometer, Keratometer
 Tonometers, Keratometer
 Tonómetros, Queratómetro
 Tonomètres, Kératomètre
 Tonometri, Cheratometro



SCHIOETZ
 13,0 cm/5"

gerade Skala
 straight scale
 graduado recto
 echelle droite
 scala retta

schräge Skala
 inclined scale
 graduado inclinado
 echelle oblique
 scala inclinata

Spezifikation Nr. 3
 Specification No. 3
 Especificación No. 3
 Spécification No. 3
 Specifica No. 3

KP 543/00

Spezifikation Nr. 5, geeicht
 Specification No. 5, calibrated
 Especificación No. 5, calibrada
 Spécification No. 5, calibrée
 Specifica No. 5, calibrata

KP 542/01

KP 543/01



1/1

MALONEY
 KP 545/02
 2,0 cm/3/4"

AA

AB

AC

AD

AE

AK

AR

KA

KM

KO

KP

KYE

XR

Messinstrumente, Tiefenlehre, Fixierringe
 Measuring Instruments, Depth Gauge, Fixation Rings
 Instrumentos de medición, Medidor de profundidad, Anillos de fijación
 Instruments de mesure, Jauge de profondeur, Anneaux de fixation
 Strumenti per la misurazione, Misuratori di profondità, Anelli di fissazione



MENDEZ
 KP 547/11
 11,0 cm/4 1/2"
 C 10°, 0 -180°



DEITZ
 9,5 cm/3 3/4"
 KP 548/50 KP 548/55
 0,50 mm 0,55 mm

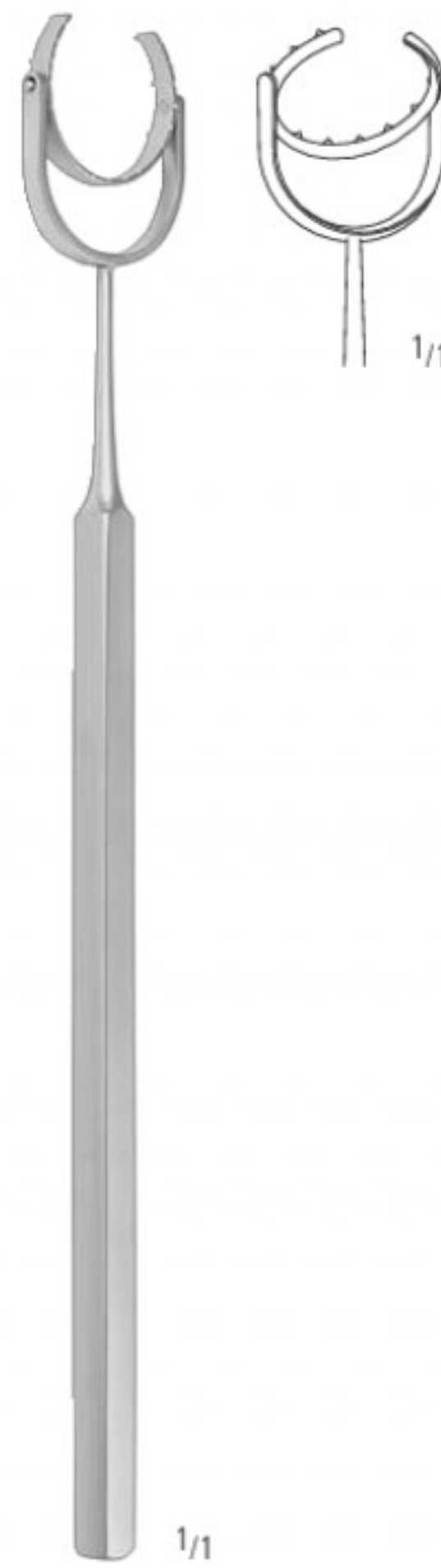

THORNTON
 KP 550/12
 12,0 cm/4 3/4"
 Ø 13 mm

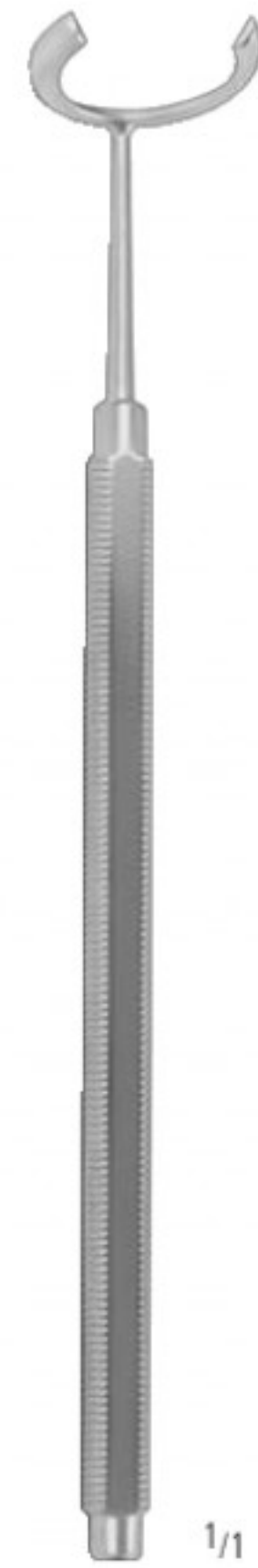

BONN
 KP 555/11
 10,5 cm/4 1/4"

Hornhautbohrer und -trephinen
 Corneal Burrs and Trephines
 Fresas y trépanos corneales
 Trépanos kératoplastie
 Trepani corneali



1/1

CASTROVIEJO
5,0 cm/2"

mm Ø	
5,0	KP 600/50
5,5	KP 600/55
6,0	KP 600/60
6,5	KP 600/65
7,0	KP 600/70
7,5	KP 600/75
8,0	KP 600/80
9,0	KP 600/90

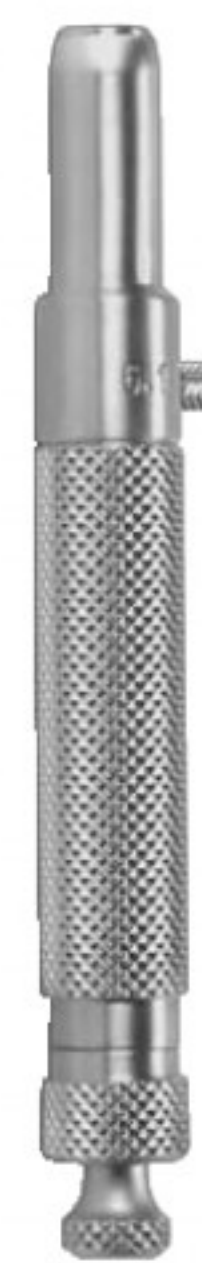

1/1

FRANCESCHETTI
7,5 cm/3"

mm Ø	
7,0	KP 603/70
7,1	KP 603/71
8,0	KP 603/80
8,1	KP 603/81



1/1

MARTIN
4,0 cm/1 1/2"

mm Ø	
5,0	KP 605/50
5,5	KP 605/55
6,0	KP 605/60
6,5	KP 605/65
6,7	KP 605/67
7,0	KP 605/70
7,2	KP 605/72
7,5	KP 605/75

mm Ø	
7,7	KP 605/77
8,0	KP 605/80
8,2	KP 605/82
8,5	KP 605/85
8,7	KP 605/87
9,0	KP 605/90
9,5	KP 605/95

AA

AB

AC

AD

AE

AK

AR

KA

KM

KO

KP

KYE

XR

Hornhautbohrer und -trephinen
 Corneal Burrs and Trephines
 Fresas y trépanos corneales
 Trépan k eratoplastie
 Trepani corneali



ELLIOT
 KP 611/00
 3,0 cm/1 1/4"



ELLIOT
 KP 612/10
 Ø 1,0 mm



ELLIOT
 KP 612/15 KP 612/20
 Ø 1,5 mm Ø 2,0 mm

ELLIOT SET

- KP 610/00 = KP 611/00
- KP 612/10
- KP 612/15
- KP 612/20

mit Etui
 with case
 con estuche
 avec bo te
 con scatola



STORZ
 KP 620/08
 8,0 cm/3 1/4"

mit 6 Fr sen
 with 6 burrs
 con 6 fresas
 avec 6 fraises
 con 6 fresas

Rostringfräse, Fixierringe,
Rust Ring Remover, Scleral Fixation Rings
Anillo removedor de óxido, Anillos de fijación
Fraise pour enlever la rouille, Anneaux de fixation
Fresa corneale, Anelli di fissazione



**RUST RING
REMOVER SET**
KP 630/00
12,5 cm/5"



KP 631/00
6 Fräsen
6 burrs
6 fresas
6 fraises
6 fresas

KP 632/00
Batterie, 2 Stück
Battery, 2 pieces
bateria, 2 piezas
piles, 2 pièces
pile, 2 pezzi

KP 630/00 = KP 631/00 + KP 632/00



FLIERINGA

mm Ø	
14	KP 640/14
16	KP 640/16
18	KP 640/18
20	KP 640/20
22	KP 640/22
24	KP 640/24

AA

AB

AC

AD

AE

AK

AR

KA

KM

KO

KP

KYE

XR

Vorderkammerspülkanülen, Silikonball, Verbindung, Spülkanülen
 Anterior Chamber Irrigation Cannula, Silicon Ball, Connection, Irrigation Cannulas
 Cánulas de irrigación para cámara anterior, Pelota de silicona, Conector, Cánulas para irrigación
 Canules à lavage pour chambre antérieure, Balle de silicone, Raccord, Canules irrigatrices
 Cannule d'irrigazione per camera anteriore, Palla di silicone, Raccordo, Cannule d'irrigazione



BISHOP-HARMON
 KP 700/00

Set komplett
 Set complete
 Juego completo
 Jeu complet
 Set completo

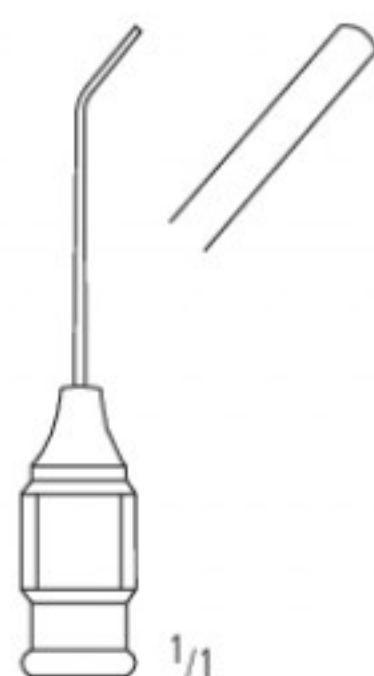

BISHOP-HARMON
 KP 701/19
 4,0 cm/1 1/2"
 19G



KP 702/00
 7,5 cm/2 3/4"

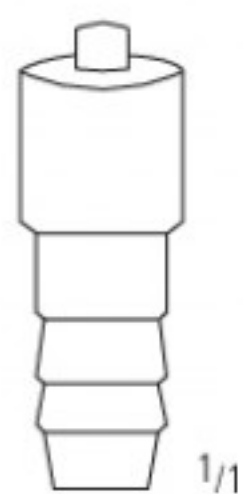

LUER-LOCK
 KP 703/00
 3,0 cm/1 1/4"



McINTYRE
 KP 704/23
 3,0 cm/1 1/4"
 23G

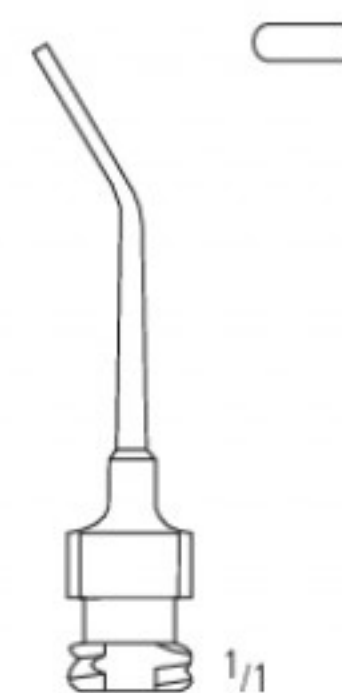

MODELL BONN
 4,0 cm/1 1/2"
 KP 705/19 KP 705/20
 19G 20G

Vorderkammer-, Saug- und Spülkanülen, Luftkanülen
 Anterior Chamber, Irrigation and Aspiration Cannulas, Air Injection Cannulas
 Cánulas para cámara anterior, irrigación y aspiración, Cánulas para inyectar aire
 Canules à chambre antérieure, irrigatrices et pour aspiration, Canules à injection d'air
 Cannule per camera anteriore, d'irrigazione e d'aspirazione, Cannule per iniettare aria

AA

AB

AC

AD

AE

AK

AR

KA

KM

KO

KP

KYE

XR

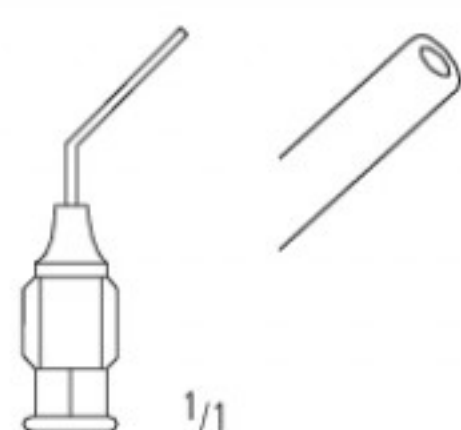

McINTYRE
 2,5 cm/1"
 KP 712/27 KP 712/30
 27G 30G

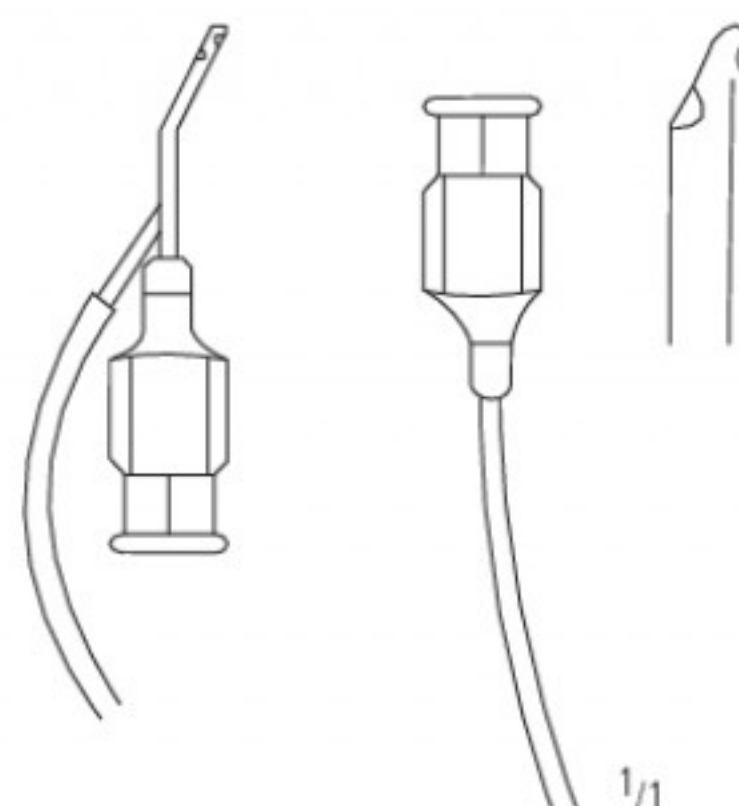

SIMCOE
 KP 720/23
 3,0 cm/1 1/4"
 25/23G

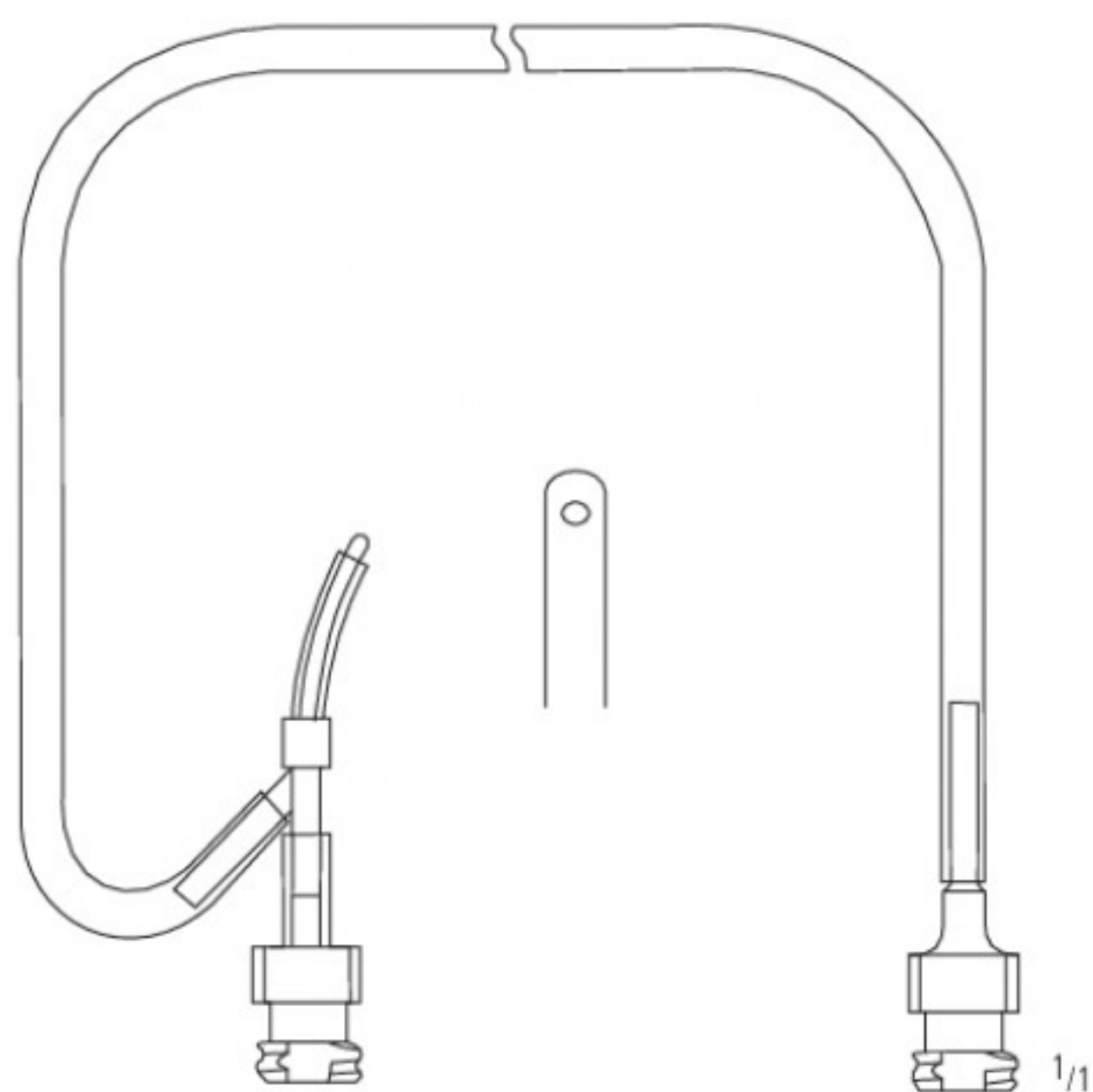

FRIEDBURG
 KP 721/00
 4,0 cm/1 1/2" 3,0 cm/1 1/4"

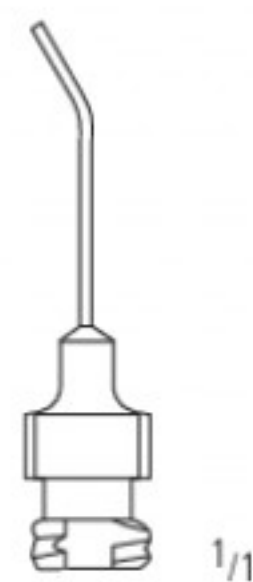

SAUTTER
 KP 730/27 KP 730/30
 27G 30G
 3,5 cm/1 1/2"

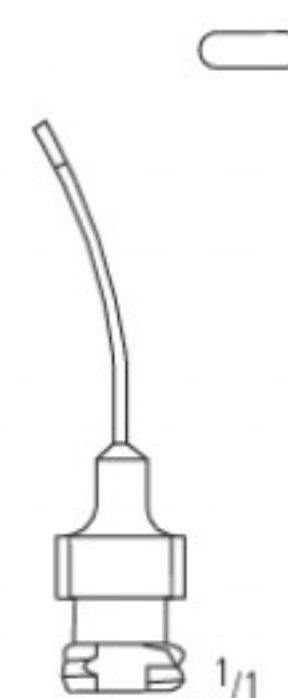

SAUTTER
 KP 731/27
 3,5 cm/1 1/2"
 27G

Tränenwegkanülen, Kortex Extraktor
 Lacrimal Cannulas, Cortex Extractor
 Cánulas lacrimales, Extractor para corteza
 Canules à voies lacrymales, Extracteur de cortex
 Cannules per vie lacrimali, Estrattore per capsula

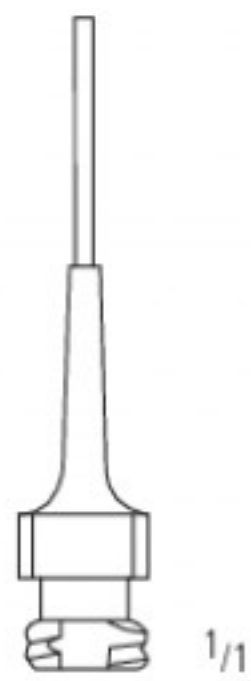

ANEL
 KP 740/23
 4,0 cm/1 1/2"
 23G



KP 741/23
 3,5 cm/1 1/2"
 23G

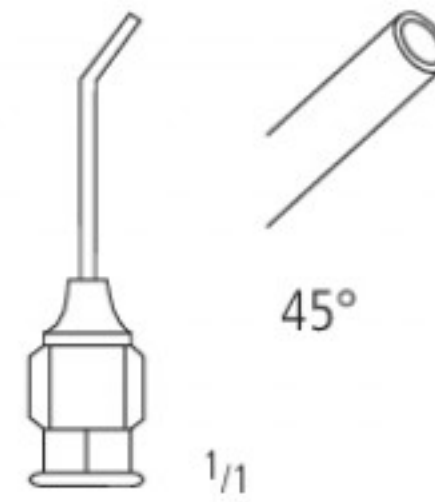

GILLS-WELSH
 KP 745/25
 3,0 cm/1 1/4"
 25G

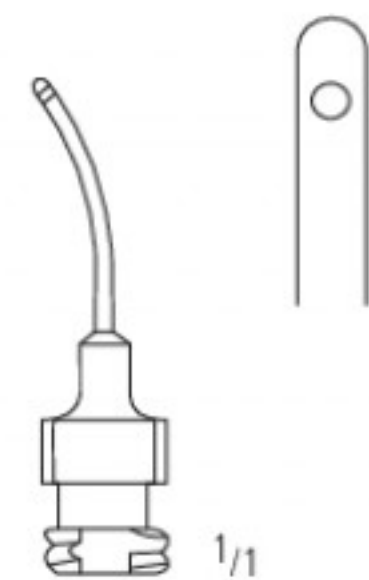

SIMCOE
 KP 746/23
 3,0 cm/1 1/4"
 23G

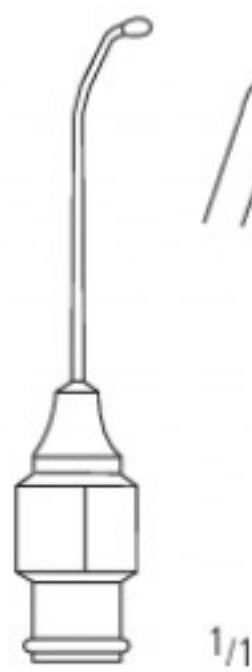

WELSH
 KP 747/00
 4,0 cm/1 1/2"
 25G

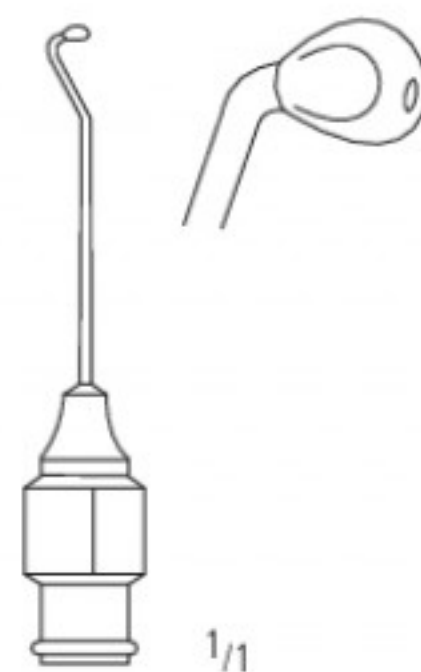

WELSH
 KP 747/01
 4,0 cm/1 1/2"
 25G

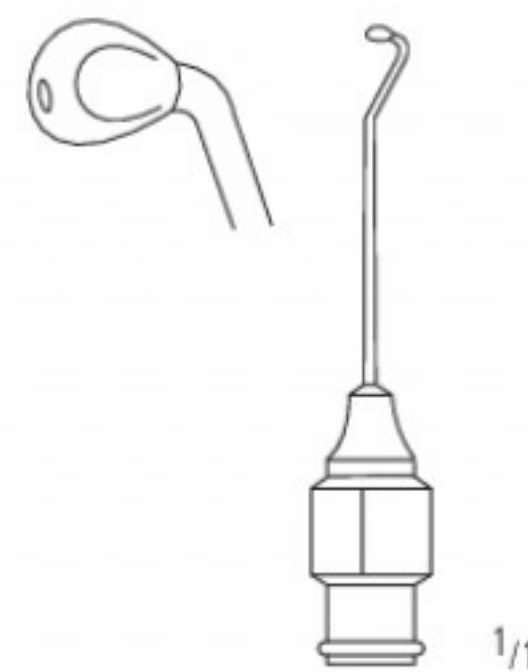

WELSH
 KP 747/02
 4,0 cm/1 1/2"
 25G

Linsenschlinge und Linsenkernschlinge mit Spülung, Injektionskanüle
 Lens Loop and Lens Nucleus Loop with Irrigation, Injection Cannula
 Asas para cristalino y Cánula para núcleo con irrigación, Cánula para inyección
 Anses à cristallin et Canula du noyau avec irrigation, Canule à injection
 Anse per cristallino con irrigazione, Irrigatore per lenti intraoculari, Cannula per lavaggio

AA

AB

AC

AD

AE

AK

AR

KA

KM

KO

KP

KYE

XR

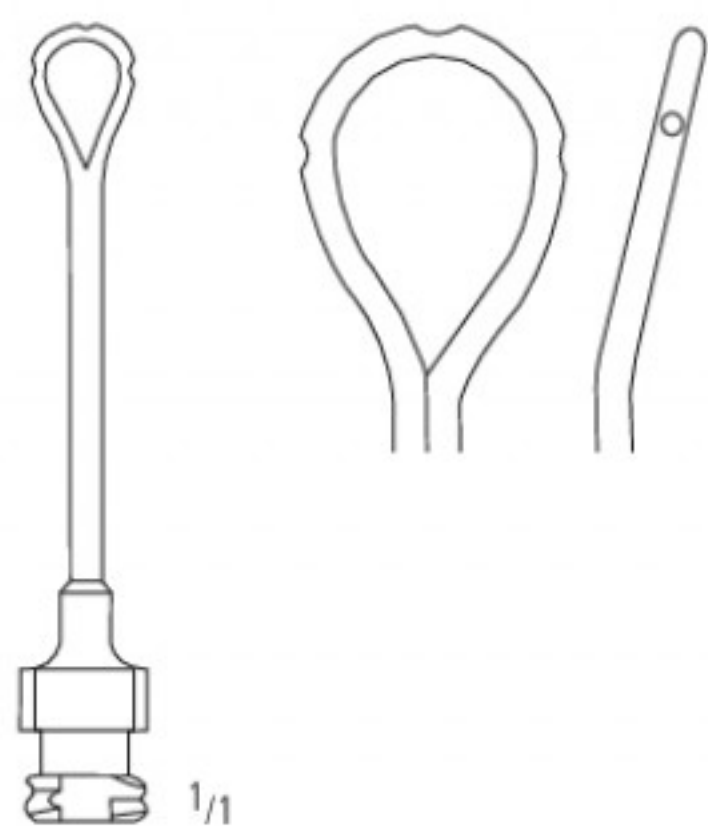

KNOLLE-PEARCE
 KP 755/23
 5,0 cm/2"
 23G

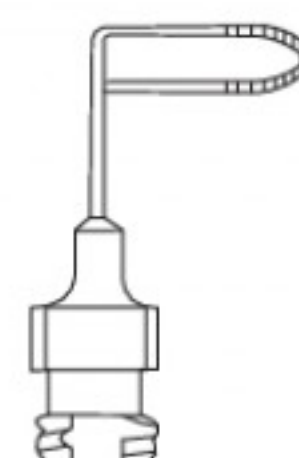
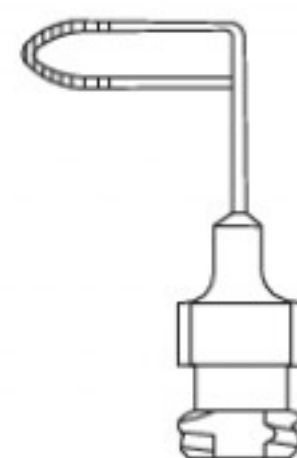
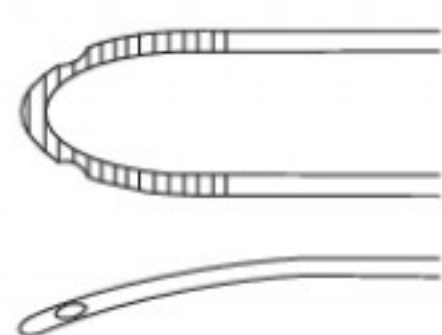

SIMCOE
 3,0 cm/1 1/4"
 KP 756/01
 25G
 KP 756/02
 25G

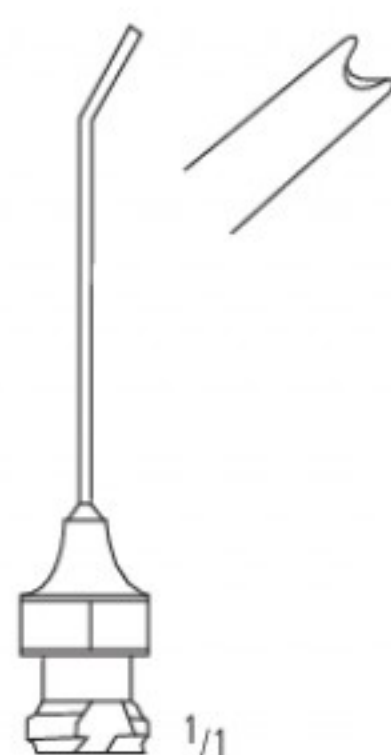

KP 760/21
 4,5 cm/2"
 21G

Kapselpolierer, Kapsel feile, Kapsel sauger
 Capsule Polisher, Capsule Scraper, Erisiphake
 Pulidor para cápsula, Erisiphake
 Canule gratteuse, Erisiphaque capsulaire
 Levigatore corneale, Aspiratore capsulare

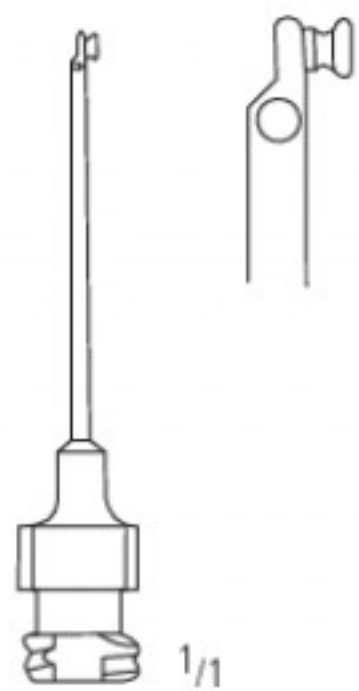

GRAETHER
 4,0 cm/1 1/2"

KP 763/01
 23G

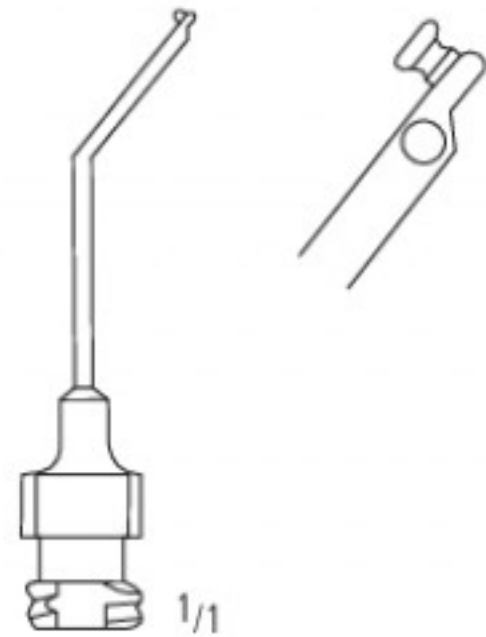

KP 763/02
 23G

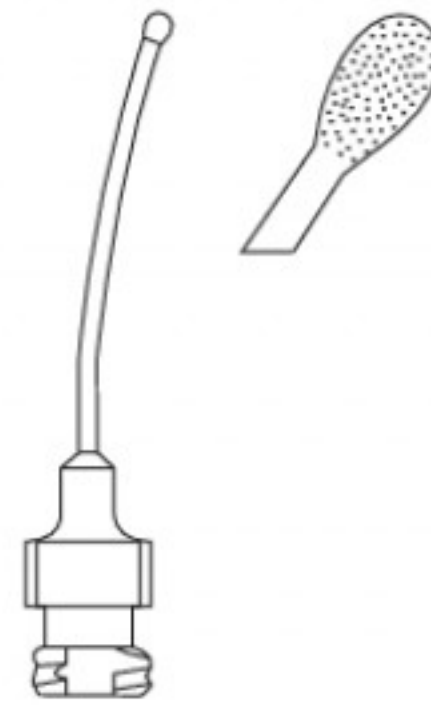

JENSEN
 KP 767/27
 4,5 cm/2"
 27G

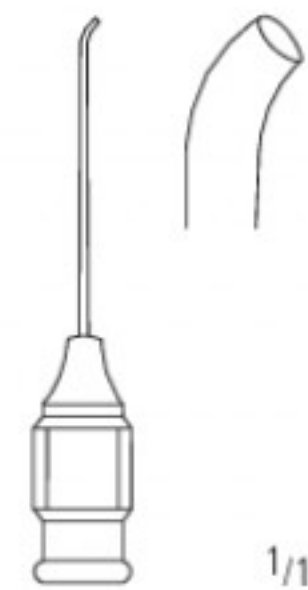

KNOLLE
 3,5 cm/1 1/2"
 KP 768/23
 23G
 KP 768/30
 30G

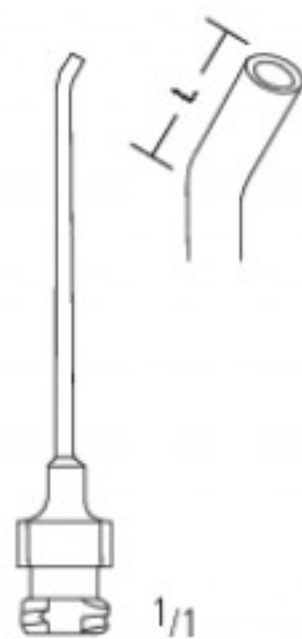

KRATZ
 3,5 cm/1 1/2"

KP 772/01
 23G
 L = 1 mm

KP 772/02
 23G
 L = 2 mm

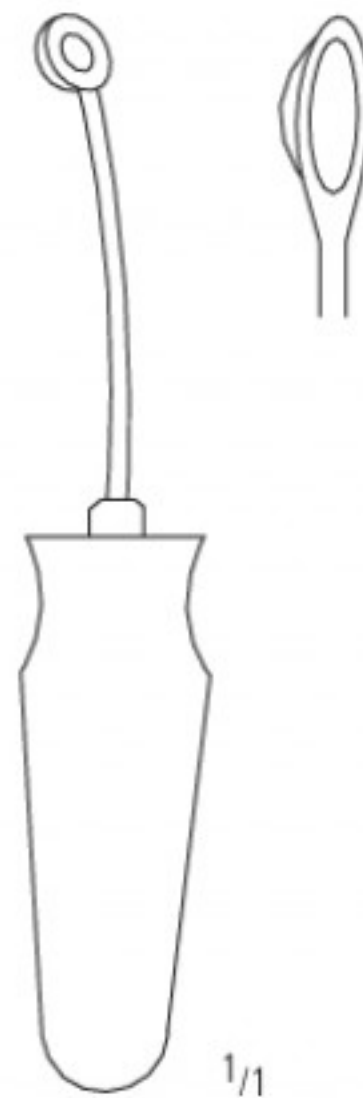

BELL
 KP 775/00
 6,5 cm/2 1/2"

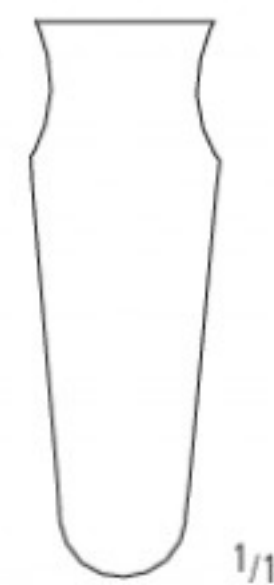

BELL
 KP 775/01

Zyklodialysen-, Alpha-Chymotrypsin- und Zystotomkanüle
 Cyclodialysis-, Alpha-Chymotrypsin- and Cystotome Cannula
 Cánula para ciclodiálisis, Alpha-Chymotrypsin y cistótomo
 Canule pour cyclodialyse, à injection Alpha-Chimo-Trypsine et cystotome
 Cannule per ciclodialisi, per alfa-chimotripsina e per cistotomi

AA

AB

AC

AD

AE

AK

AR

KA

KM

KO

KP

KYE

XR

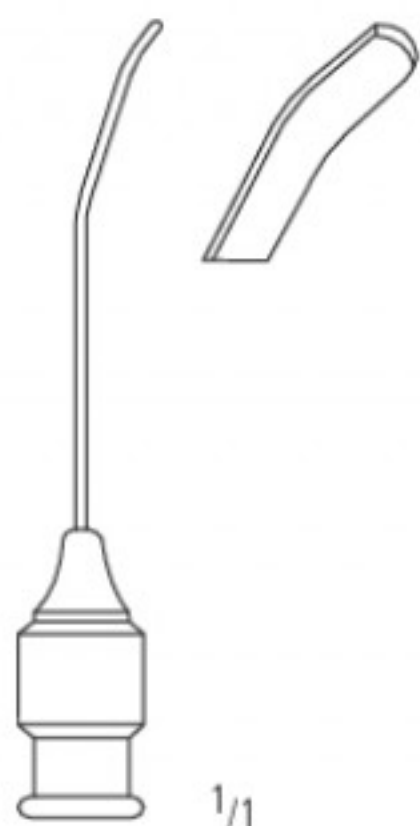

KELMAN
4,0 cm/1 1/2"

KP 780/01
19G

KP 780/02
19G

rechts
right
derecho
droit
destro

links
left
izquierda
gauche
sinistro

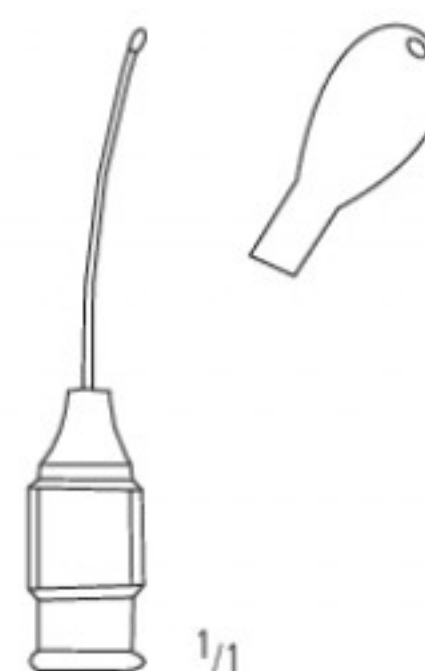

TROUTMAN
KP 783/25
4,5 cm/2"

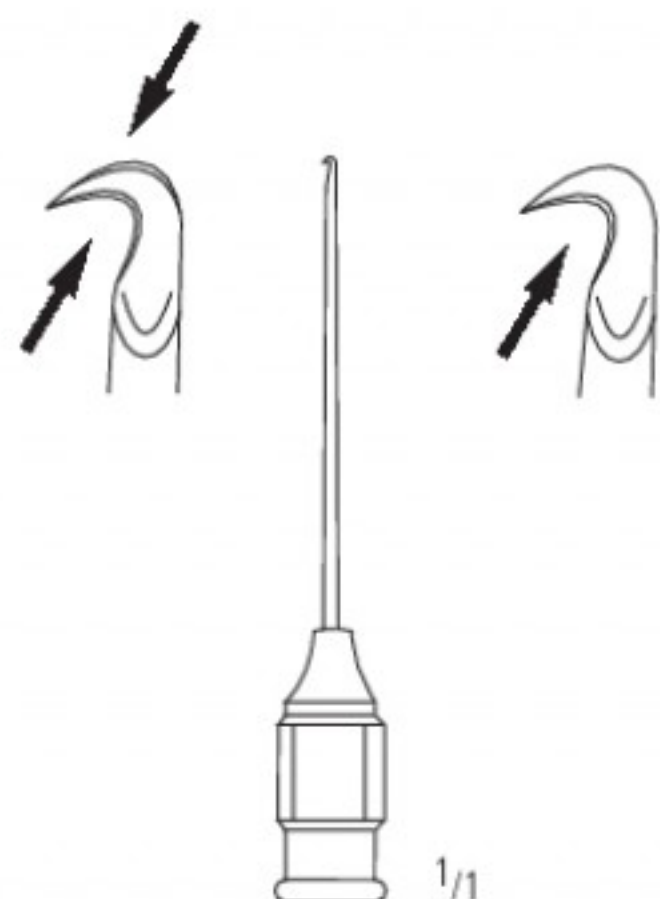

KELMAN
4,5 cm/2"

KP 786/00
22G

KP 786/01
22G

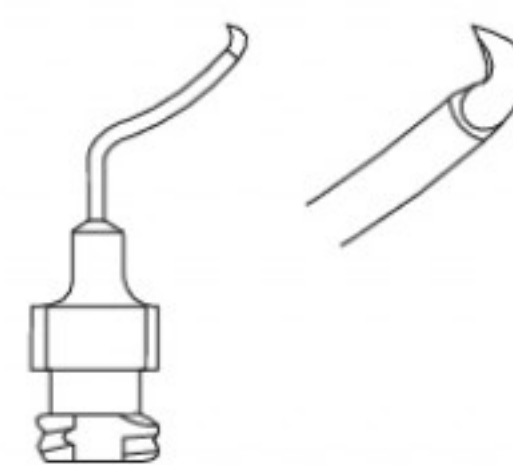

KRATZ
KP 788/22
3,0 cm/1 1/4"
22G

Augennadeln
 Eye Needles
 Agujas oculares
 Aiguilles ophtalmiques
 Aghi oftalmichi

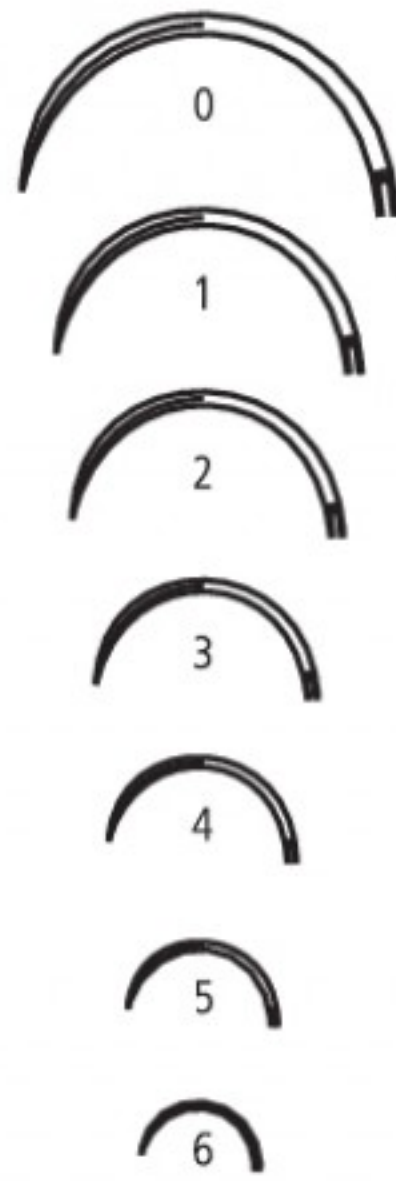

OG
 gebogen 1/2 Kreis
 curved 1/2 circle
 curvas 1/2 círculo
 courbes 1/2 cercle
 curvi 1/2 circolo



gewöhnliches Ohr
 regular eye
 ojo ordinario
 chas régulier
 cruna ordinaria

Federöhr
 spring eye
 ojo de resorte
 chas à ressort
 cruna a molla

- KP 950/00
- KP 950/01
- KP 950/02
- KP 950/03
- KP 950/04
- KP 950/05
- KP 950/06

- KP 951/00
- KP 951/01
- KP 951/02
- KP 951/03
- KP 951/04
- KP 951/05
- KP 951/06

- FIG. 0**
- FIG. 1**
- FIG. 2**
- FIG. 3**
- FIG. 4**
- FIG. 5**
- FIG. 6**

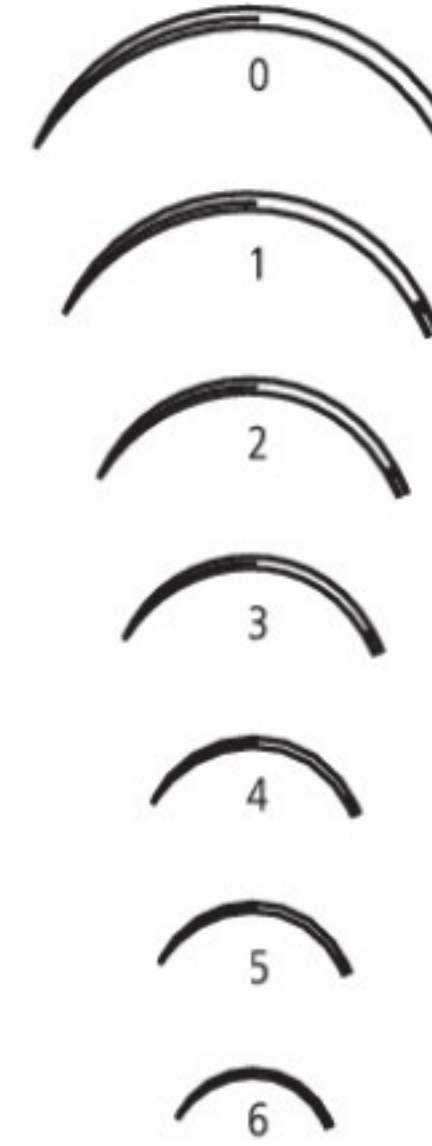

OB
 gebogen 3/8 Kreis
 curved 3/8 circle
 curvas 3/8 círculo
 courbes 3/8 cercle
 curvi 3/8 circolo



gewöhnliches Ohr
 regular eye
 ojo ordinario
 chas régulier
 cruna ordinaria

Federöhr
 spring eye
 ojo de resorte
 chas à ressort
 cruna a molla

- KP 952/00
- KP 952/01
- KP 952/02
- KP 952/03
- KP 952/04
- KP 952/05
- KP 952/06

- KP 953/00
- KP 953/01
- KP 953/02
- KP 953/03
- KP 953/04
- KP 953/05
- KP 953/06

Verkaufseinheit 1 Dutzend
 unit for sale 1 dozen
 unidad de venta 1 docena
 unité d' 1 douzaine
 unità di vendita 1 dozzina

Augenklappen, Pinsel
 Eye Patches, Brushes
 Protectores de ojos, Pincel
 Bandeaux pour les yeux, Pinceau
 Benda di protezione per gli occhi, Pennello

AA

AB

AC

AD

AE

AK

AR

KA

KM

KO

KP

KYE

XR



KP 955/01



KP 955/02



KP 956/00



BARRAQUER
 KP 959/00

STERILISATION
STERILIZATION
ESTERILIZACION
STERILISATION
STERILIZZAZIONE

KYE

nopa[®] instruments



Erklärung zu unseren Symbolen • Explanation of our symbols • Explicación de nuestros símbolos
 • Explication de nos figures • Spiegazione dei nostri simboli

Wanne • Bottom • Fondo • Fond • Fondo

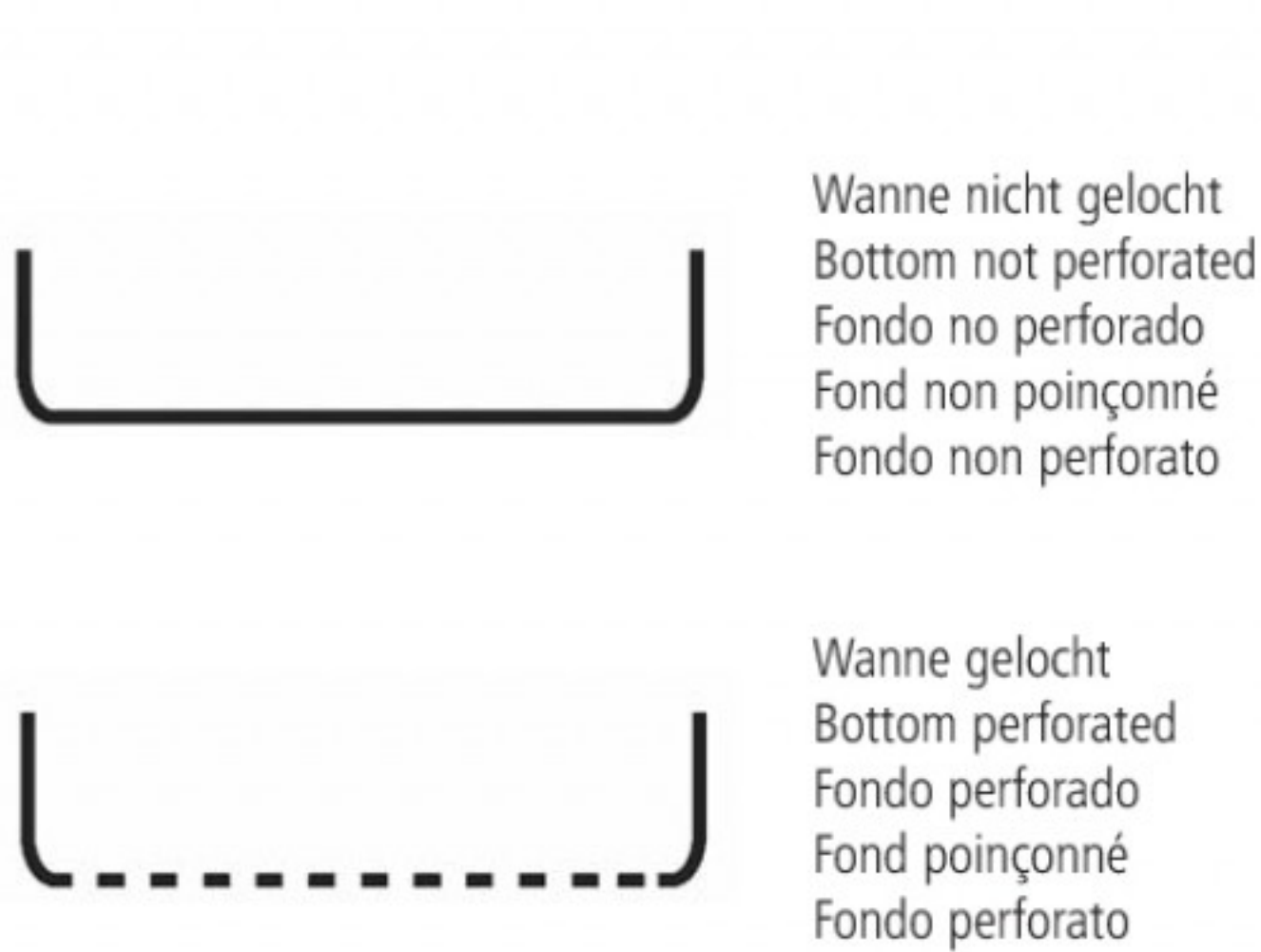

Deckel • Lid • Tapa • Couvercle • Coperchio

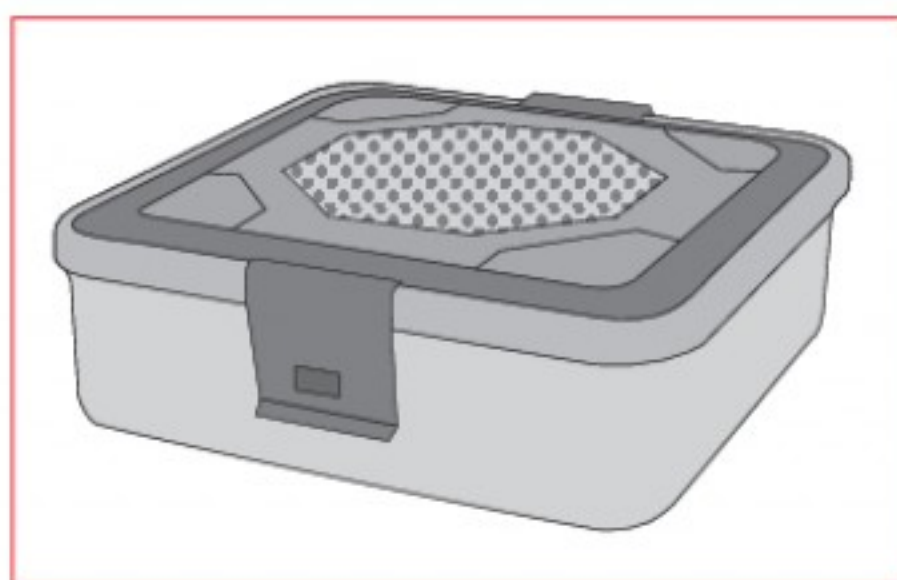
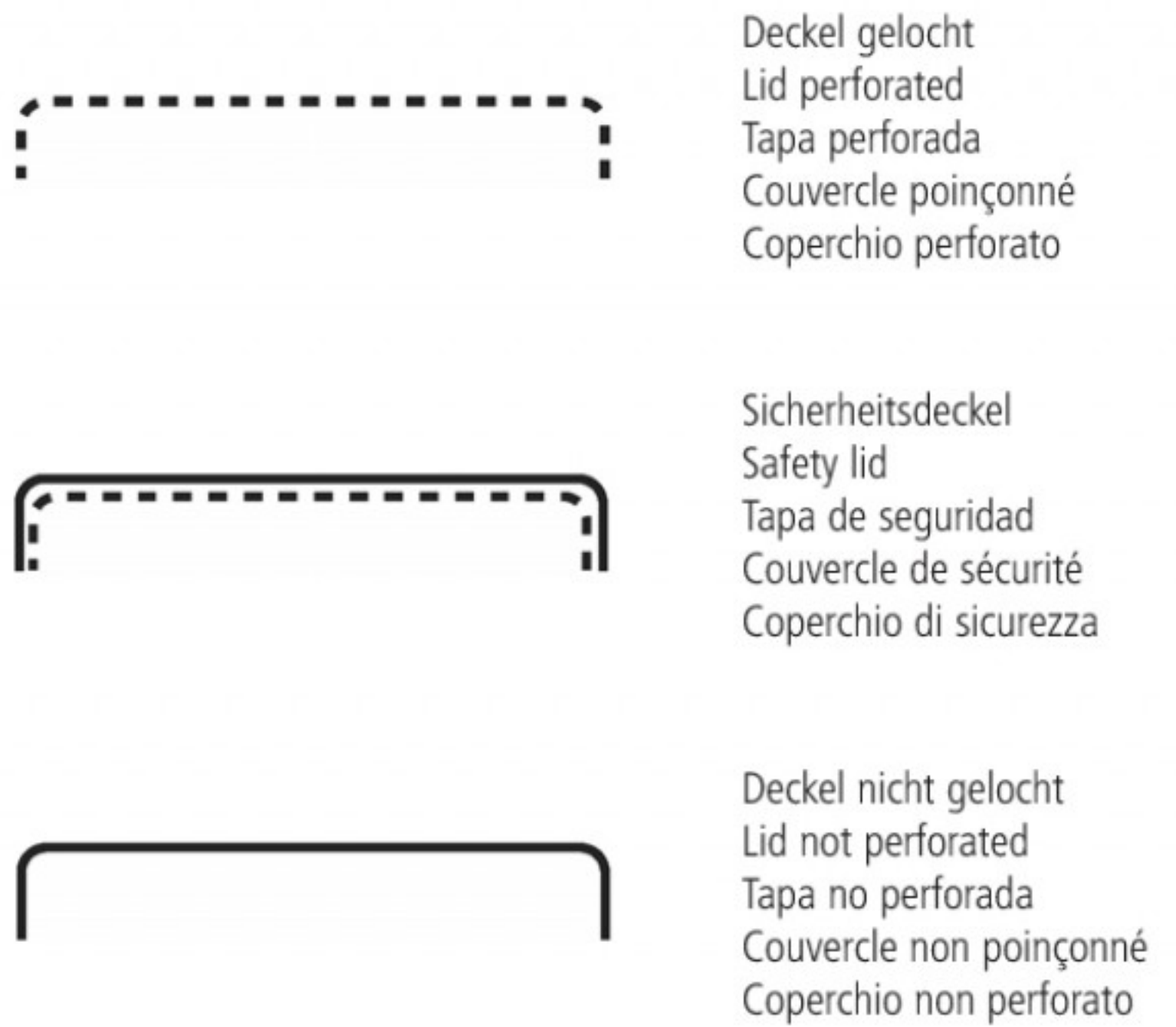

Zur Verwendung mit Sterilisationscontainern
 For use with sterilization containers
 Por uso con contenedores de esterilización
 Pour l'usage avec des conteneurs de sterilisation
 Per l'uso con contenitori di sterilizzazione

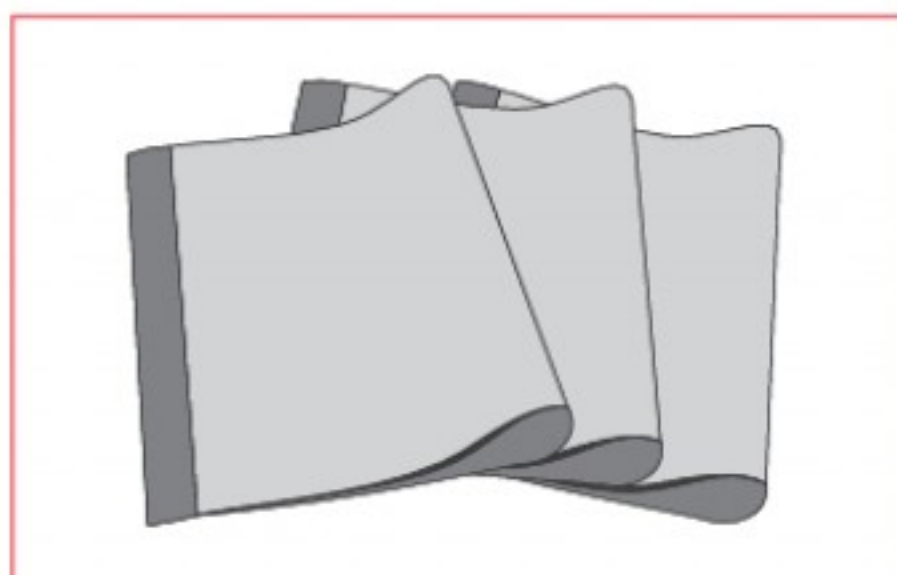

Zur Verwendung mit Weichverpackung
 For the use with soft packaging materials
 Por uso con envase blando
 Pour l'usage avec des emballages mous
 Per l'uso con imballaggio blando

1/2 Container

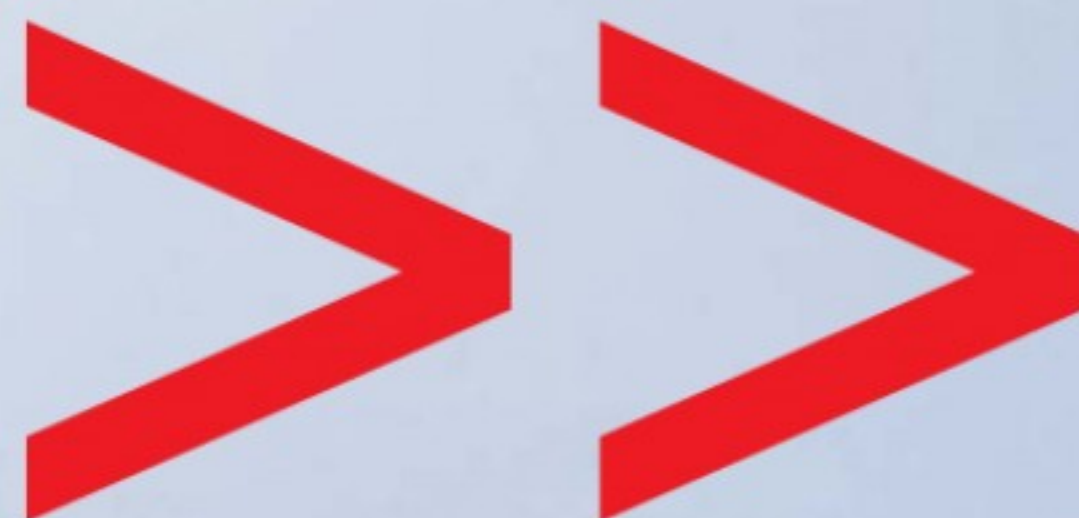



Nur Deckel farbig
Lid colored only
Solamente tapas en diferentes colores
Couvercle de couleur seulement
Solo coperchio colorato

L(mm)	B(mm)	H(mm)						
285	280	100	KYE 200/01	KYE 200/02	KYE 200/03	KYE 200/04	KYE 200/05	KYE 200/06
285	280	135	KYE 200/11	KYE 200/12	KYE 200/13	KYE 200/14	KYE 200/15	KYE 200/16
285	280	150	KYE 200/21	KYE 200/22	KYE 200/23	KYE 200/24	KYE 200/25	KYE 200/26
285	280	200	KYE 200/31	KYE 200/32	KYE 200/33	KYE 200/34	KYE 200/35	KYE 200/36
285	280	260	KYE 200/41	KYE 200/42	KYE 200/43	KYE 200/44	KYE 200/45	KYE 200/46



Nur Deckel farbig
Lid colored only
Solamente tapas en diferentes colores
Couvercle de couleur seulement
Solo coperchio colorato

L(mm)	B(mm)	H(mm)						
285	280	100	KYE 204/01	KYE 204/02	KYE 204/03	KYE 204/04	KYE 204/05	KYE 204/06
285	280	135	KYE 204/11	KYE 204/12	KYE 204/13	KYE 204/14	KYE 204/15	KYE 204/16
285	280	150	KYE 204/21	KYE 204/22	KYE 204/23	KYE 204/24	KYE 204/25	KYE 204/26
285	280	200	KYE 204/31	KYE 204/32	KYE 204/33	KYE 204/34	KYE 204/35	KYE 204/36
285	280	260	KYE 204/41	KYE 204/42	KYE 204/43	KYE 204/44	KYE 204/45	KYE 204/46

Wanne gelocht
Bottom perforated
Fondo perforado
Fond poinçonné
Fondo perforato



L(mm)	B(mm)	H(mm)	
285	280	100	KYE 284/10
285	280	135	KYE 284/13
285	280	150	KYE 284/15
285	280	200	KYE 284/20
285	280	260	KYE 284/26

Wanne nicht gelocht
Bottom not perforated
Fondo no perforado
Fond non poinçonné
Fondo non perforato



L(mm)	B(mm)	H(mm)	
285	280	100	KYE 286/10
285	280	135	KYE 286/13
285	280	150	KYE 286/15
285	280	200	KYE 286/20
285	280	260	KYE 286/26

Deckel gelocht
Lid perforated
Tapa perforada
Couvercle poinçonné
Coperchio perforato



L(mm)	B(mm)						
285	280						
		KYE 280/01	KYE 280/02	KYE 280/03	KYE 280/04	KYE 280/05	KYE 280/06

Sicherheitsdeckel
Safety lid
Tapa de seguridad
Couvercle de sécurité
Coperchio di sicurezza



L(mm)	B(mm)						
285	280						
		KYE 281/01	KYE 281/02	KYE 281/03	KYE 281/04	KYE 281/05	KYE 281/06

Deckel nicht gelocht
Lid not perforated
Tapa no perforada
Couvercle non poinçonné
Coperchio non perforato



L(mm)	B(mm)						
285	280						
		KYE 289/01	KYE 289/02	KYE 289/03	KYE 289/04	KYE 289/05	KYE 289/06

AA

AB

AC

AD

AE

AK

AR

KA

KM

KO

KP

KYE

XR



L(mm)	B(mm)	H(mm)	
255	245	30	SK 105/03
255	245	50	SK 105/05
255	245	70	SK 105/07
255	245	100	SK 105/10

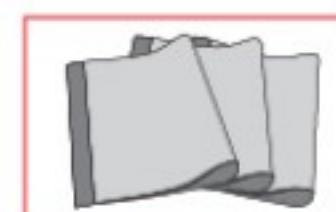

L(mm)	B(mm)	
255	245	SK 105/50

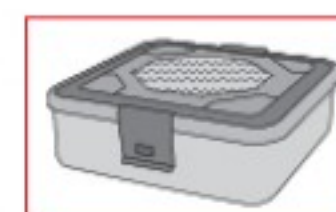

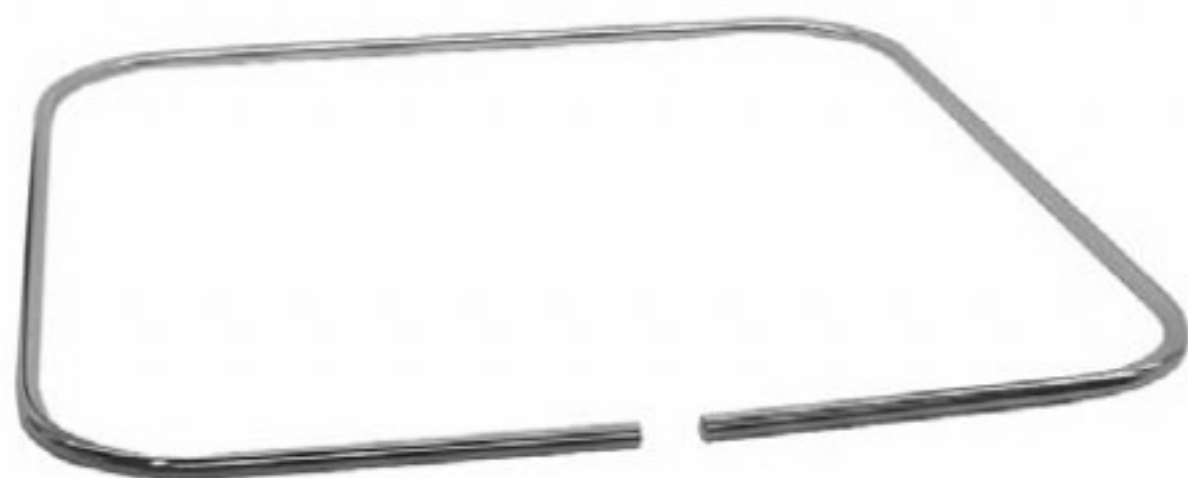

L(mm) **B(mm)**
255 255

SK 105/61



L(mm) **B(mm)** **H(mm)**
255 255 30

SK 105/62

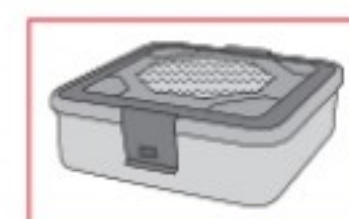

L(mm) **B(mm)** **H(mm)**
255 245 130

SK 105/71

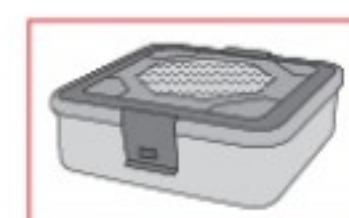

AA

AB

AC

AD

AE

AK

AR

KA

KM

KO

KP

KYE

XR

Lochblechsiebkorb
 Perforated steel basket
 Cestilla de acero perforado
 Panier d'acier poinçonné
 Cestello d'acciaio perforato

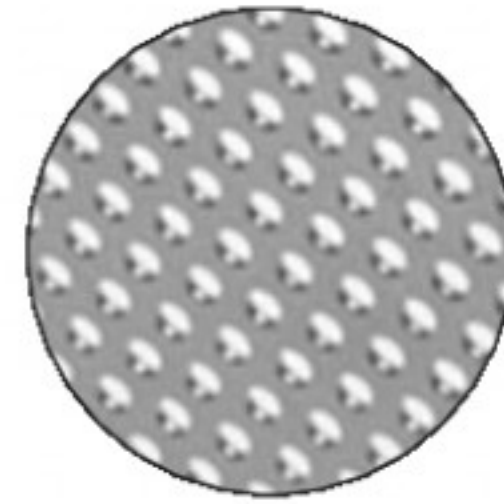
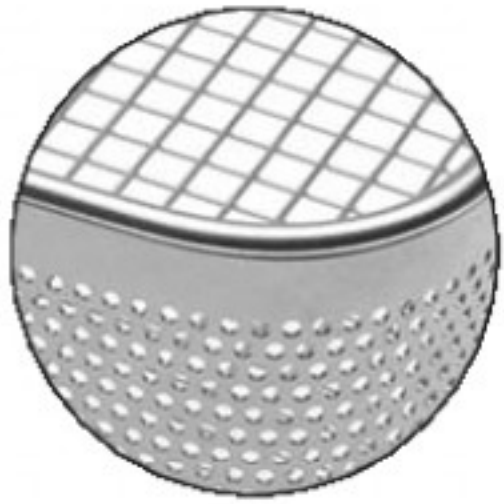

Aufsatz für Lochblechsiebkorb
 Body extention for perforated steel basket
 Borde complementario para cestilla de acero perforado
 Bordure pour panier d'acier poinçonné
 Bordo rialzato per cestello d'acciaio perforato



L(mm) B(mm) H(mm)
 240 250 60 SK 110/06

L(mm) B(mm) H(mm)
 240 250 60 SK 110/16

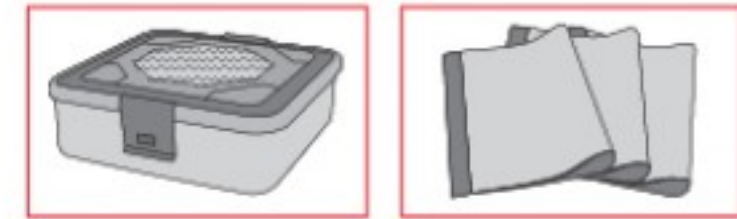
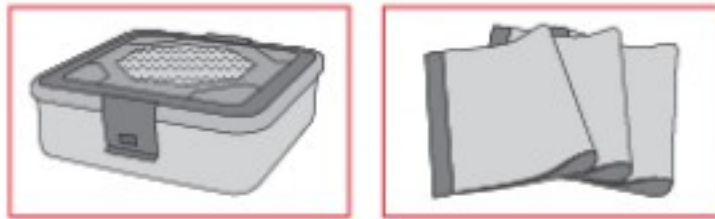

Siebdeckel
 Top for basket
 Tapa para cestilla
 Couvercle pour panier
 Copericho per cestello

Siebrahmen
 Bottom for basket
 Fondo para cestilla
 Fond pour panier
 Fondo per cestello

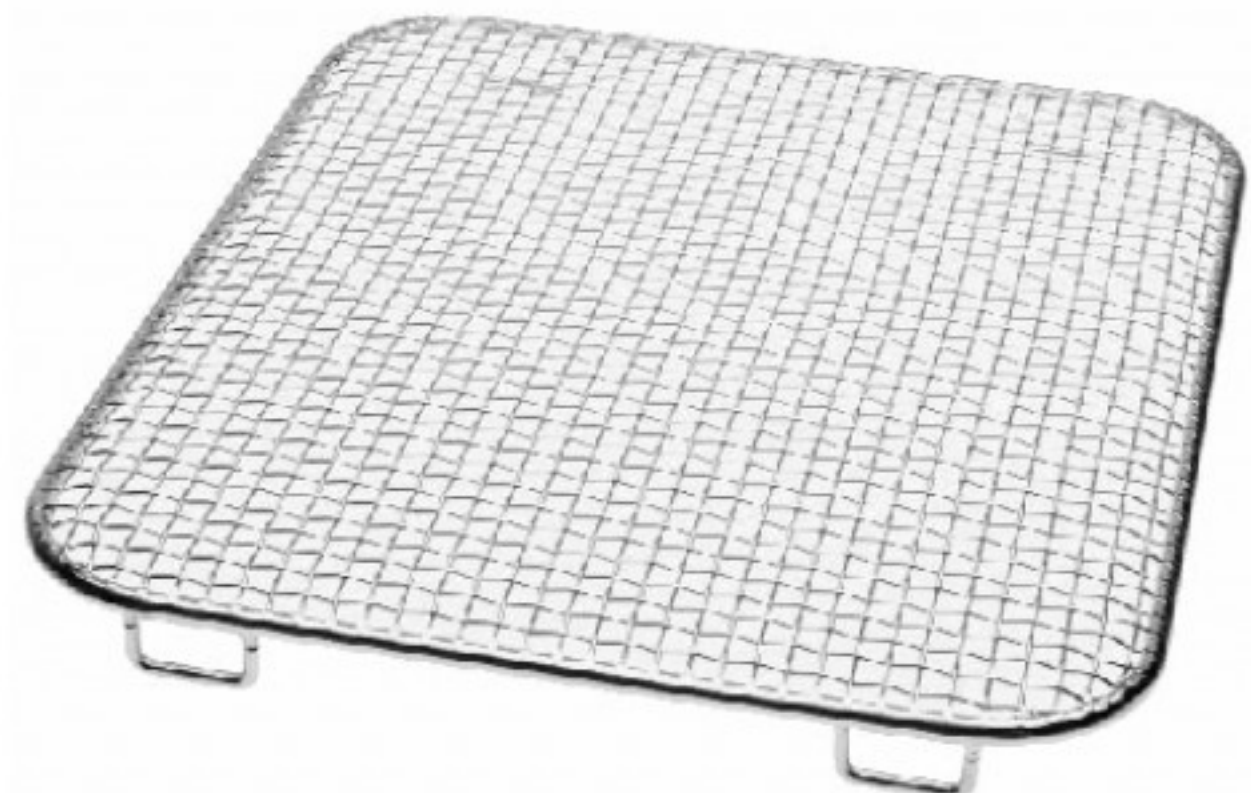
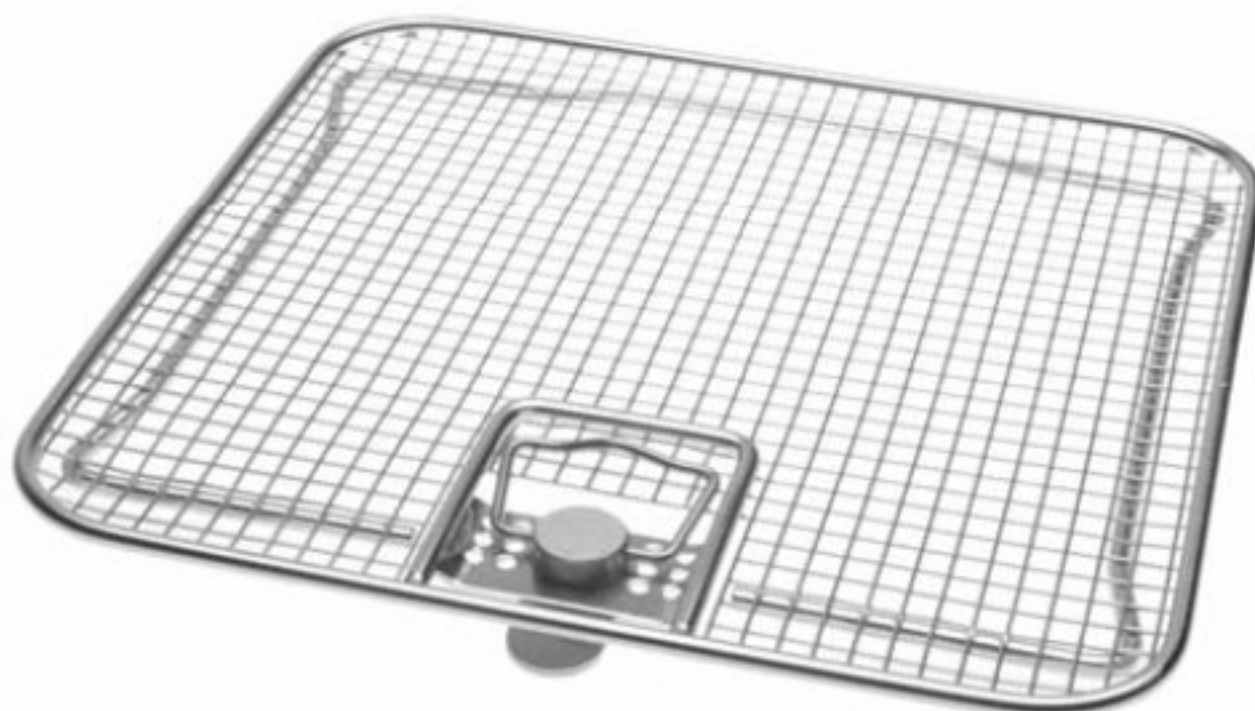

L(mm) B(mm)
 240 250 SK 110/50

L(mm) B(mm)
 240 250 SK 110/71

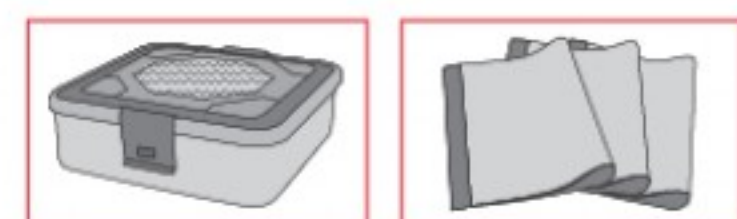
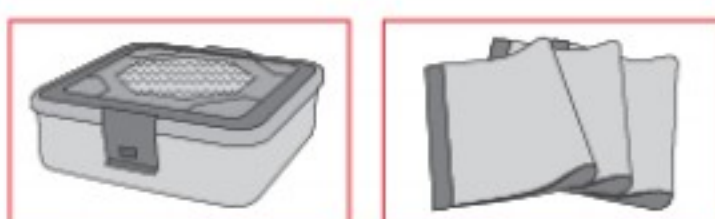







Flach Container Flat Container

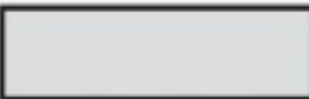







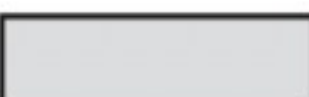

Nur Deckel farbig
Lid colored only
Solamente tapas en diferentes colores
Couvercle de couleur seulement
Solo coperchio colorato

L(mm)	B(mm)	H(mm)						
285	280	55	KYE 190/01	KYE 190/02	KYE 190/03	KYE 190/04	KYE 190/05	KYE 190/06
285	280	85	KYE 195/01	KYE 195/02	KYE 195/03	KYE 195/04	KYE 195/05	KYE 195/06



Nur Deckel farbig
Lid colored only
Solamente tapas en diferentes colores
Couvercle de couleur seulement
Solo coperchio colorato

L(mm)	B(mm)	H(mm)						
285	280	55	KYE 196/01	KYE 196/02	KYE 196/03	KYE 196/04	KYE 196/05	KYE 196/06
285	280	85	KYE 198/01	KYE 198/02	KYE 198/03	KYE 198/04	KYE 198/05	KYE 198/06

Wanne gelocht
Bottom perforated
Fondo perforado
Fond poinçonné
Fondo perforato



L(mm)	B(mm)	H(mm)	
285	280	55	KYE 284/05
285	280	85	KYE 284/08







Wanne nicht gelocht
Bottom not perforated
Fondo no perforado
Fond non poinçonné
Fondo non perforato

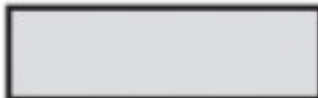

L(mm)	B(mm)	H(mm)	
285	280	55	KYE 286/05
285	280	85	KYE 286/08







Deckel gelocht
Lid perforated
Tapa perforada
Couvercle poinçonné
Coperchio perforato



L(mm)	B(mm)						
285	280						
		KYE 280/11	KYE 280/12	KYE 280/13	KYE 280/14	KYE 280/15	KYE 280/16

Deckel nicht gelocht
Lid not perforated
Tapa no perforada
Couvercle non poinçonné
Coperchio non perforato



L(mm)	B(mm)						
285	280						
		KYE 289/11	KYE 289/12	KYE 289/13	KYE 289/14	KYE 289/15	KYE 289/16

AA

AB

AC

AD

AE

AK

AR

KA

KM

KO

KP

KYE

XR



L(mm)	B(mm)	H(mm)	
255	245	30	SK 105/03
255	245	50	SK 105/05

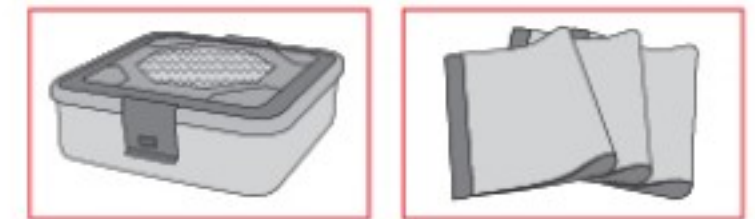

L(mm)	B(mm)	
255	245	SK 105/50

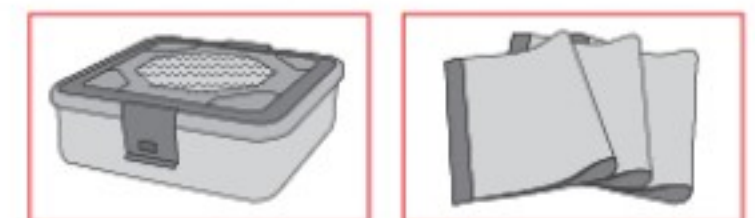

L(mm)	B(mm)	
255	255	SK 105/61

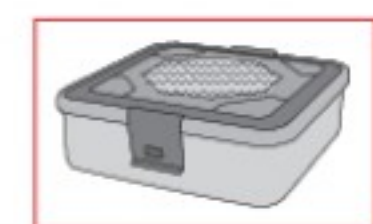

L(mm)	B(mm)	H(mm)	
255	255	30	SK 105/62

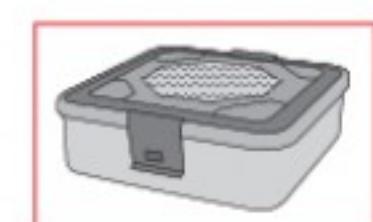

Klein Set Container Small Set Container

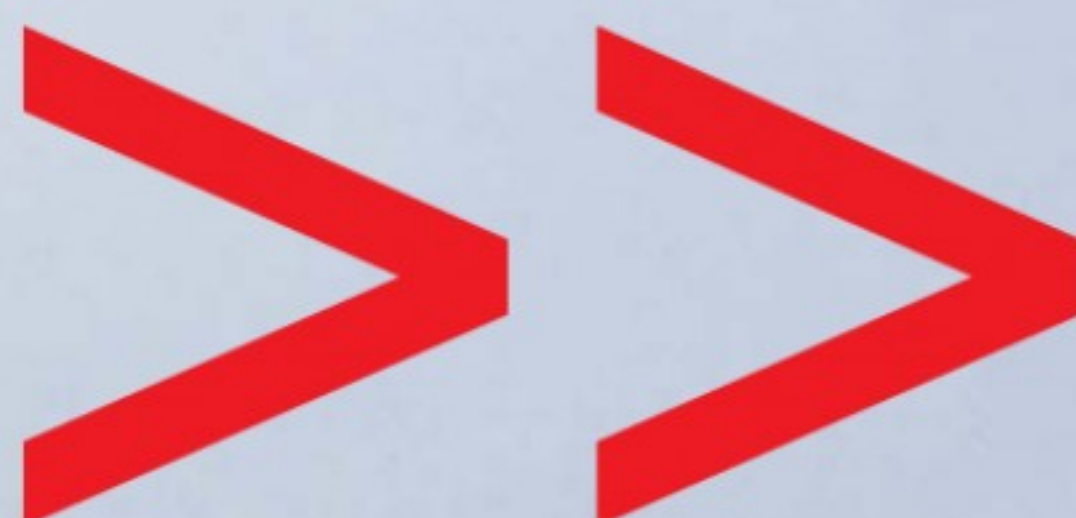



Nur Deckel farbig
Lid colored only
Solamente tapas en diferentes colores
Couvercle de couleur seulement
Solo coperchio colorato

L(mm)	B(mm)	H(mm)						
300	140	40	KYE 350/01	KYE 350/02	KYE 350/03	KYE 350/04	KYE 350/05	KYE 350/06
300	140	70	KYE 351/01	KYE 351/02	KYE 351/03	KYE 351/04	KYE 351/05	KYE 351/06
300	140	100	KYE 352/01	KYE 352/02	KYE 352/03	KYE 352/04	KYE 352/05	KYE 352/06



Nur Deckel farbig
Lid colored only
Solamente tapas en diferentes colores
Couvercle de couleur seulement
Solo coperchio colorato

L(mm)	B(mm)	H(mm)						
300	140	40	KYE 353/01	KYE 353/02	KYE 353/03	KYE 353/04	KYE 353/05	KYE 353/06
300	140	70	KYE 354/01	KYE 354/02	KYE 354/03	KYE 354/04	KYE 354/05	KYE 354/06
300	140	100	KYE 355/01	KYE 355/02	KYE 355/03	KYE 355/04	KYE 355/05	KYE 355/06

Wanne gelocht
Bottom perforated
Fondo perforado
Fond poinçonné
Fondo perforato



L(mm)	B(mm)	H(mm)	
300	140	40	KYE 360/04
300	140	70	KYE 360/07
300	140	100	KYE 360/10







Wanne nicht gelocht
Bottom not perforated
Fondo no perforado
Fond non poinçonné
Fondo non perforato

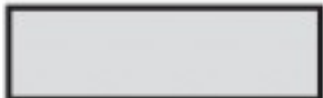

L(mm)	B(mm)	H(mm)	
300	140	40	KYE 361/04
300	140	70	KYE 361/07
300	140	100	KYE 361/10







Deckel gelocht
Lid perforated
Tapa perforada
Couvercle poinçonné
Coperchio perforato



L(mm)	B(mm)						
300	140						
		KYE 288/01	KYE 288/02	KYE 288/03	KYE 288/04	KYE 288/05	KYE 288/06

Deckel nicht gelocht
Lid not perforated
Tapa no perforada
Couvercle non poinçonné
Coperchio non perforato



L(mm)	B(mm)						
300	140						
		KYE 289/81	KYE 289/82	KYE 289/83	KYE 289/84	KYE 289/85	KYE 289/86

AA

AB

AC

AD

AE

AK

AR

KA

KM

KO

KP

KYE

XR



L(mm)	B(mm)	H(mm)	
267	125	50	SK 405//05

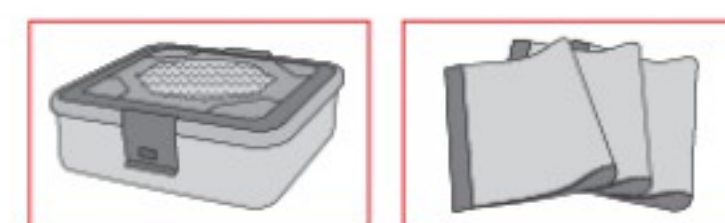

L(mm)	B(mm)	
270	125	SK 405/61



L(mm)	B(mm)	H(mm)	
270	125	30	SK 405/71



ZUBEHÖR
ACCESSORIES
ACCESORIOS
ACCESSOIRES
ACCESSORI

SX

nopa[®] instruments



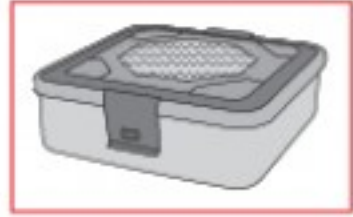

FILTER >> FILTERS >> FILTROS >> FILTRES >> FILTRI

PAPIER
PAPER
PAPEL
PAPIERS
CARTA



Standard

x 1000
SX 231/01



TEXTIL
TEXTILE
TEJIDO
TEXTILE
TESSILI

x 1
SX 233/01

PAPIER
PAPER
PAPEL
PAPIERS
CARTA



Kleinset = 235 x 118 mm
Small set = 235 x 118 mm

x 1000
SX 231/21



TEXTIL
TEXTILE
TEJIDO
TEXTILE
TESSILI

x 1
SX 233/21

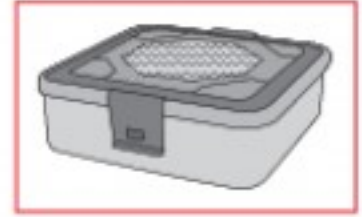

AA

AB

AC

AD

AE

AK

AR

KA

KM

KO

KP

KYE

XR



SX 237/00



SX 239/00



x 100
SX 241/01

Standard



x 100
SX 250/01

Klein / Small



x 100
SX 250/02

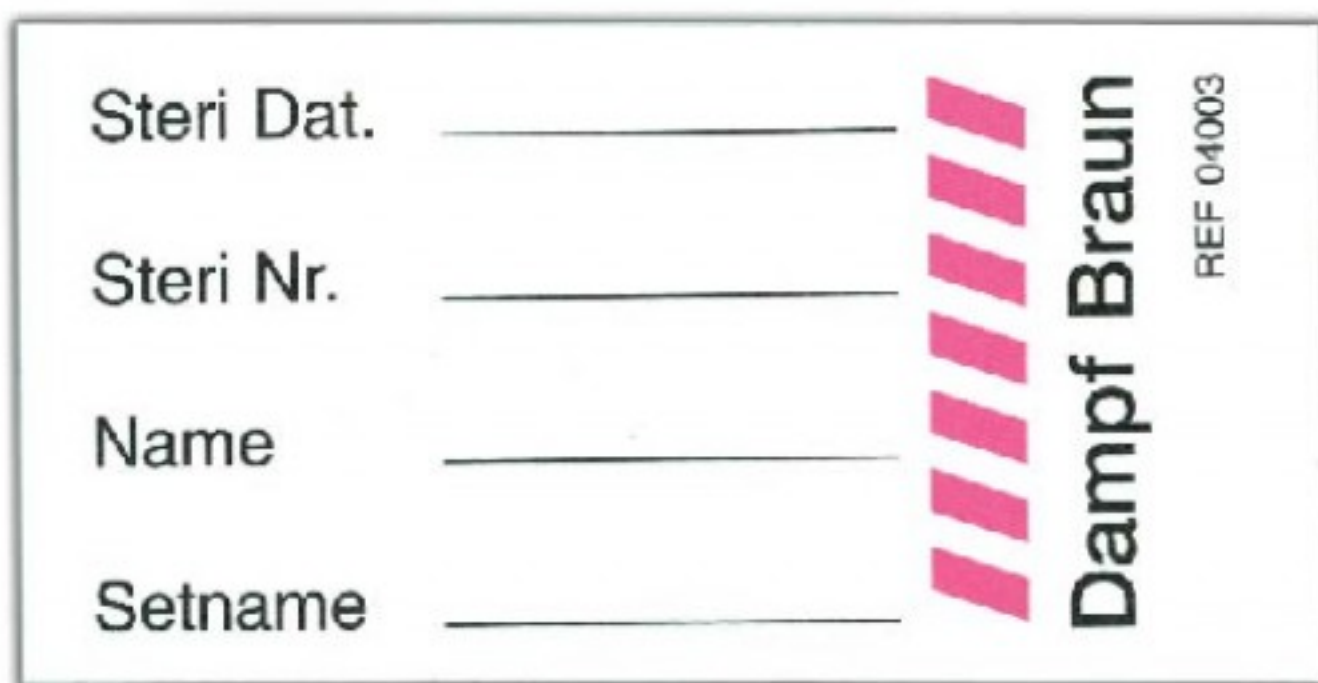

SX 253/01
40 x 80 mm

1/1

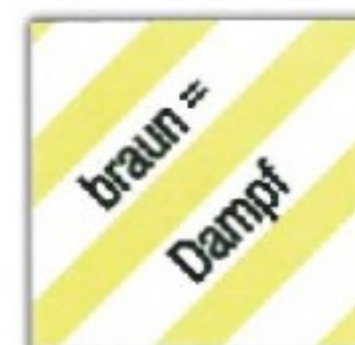

SX 253/05
20 x 20 mm

1/1

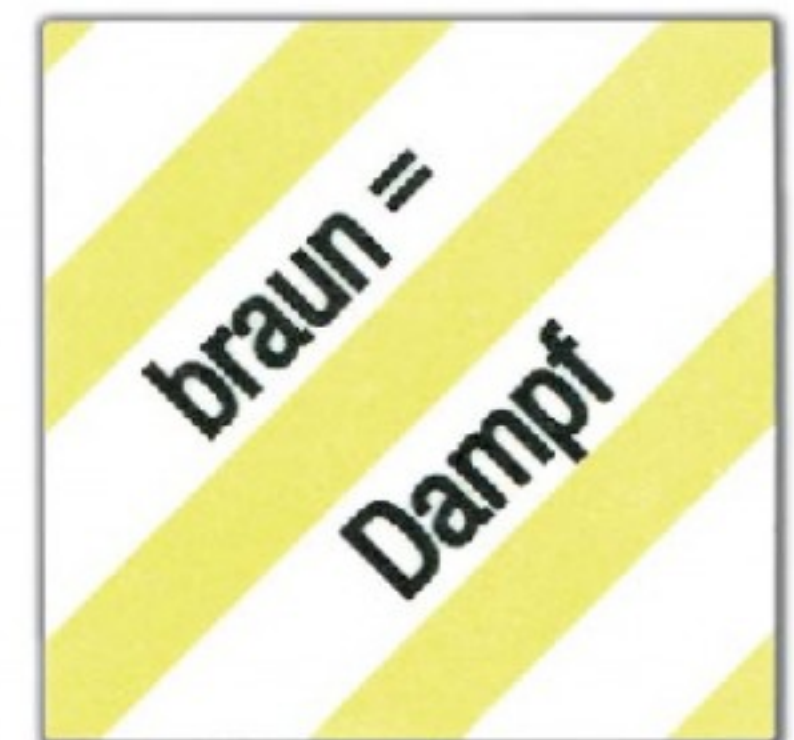

SX 253/06
45 x 45 mm

1/1

Kennzeichnungsschilder aus Aluminium
 Aluminium labels
 Etiquetas de aluminio
 Étiquettes de marquage en aluminium
 Etichette d'alluminio

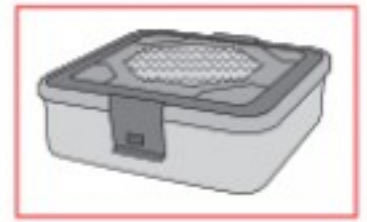

SX 255/01

SX 255/02

SX 255/03

SX 255/04

SX 255/05

SX 255/06

max. 12 Zeichen
 max. 12 Digits



SX 257/01

SX 257/02

SX 257/03

SX 257/04

SX 257/05

SX 257/06

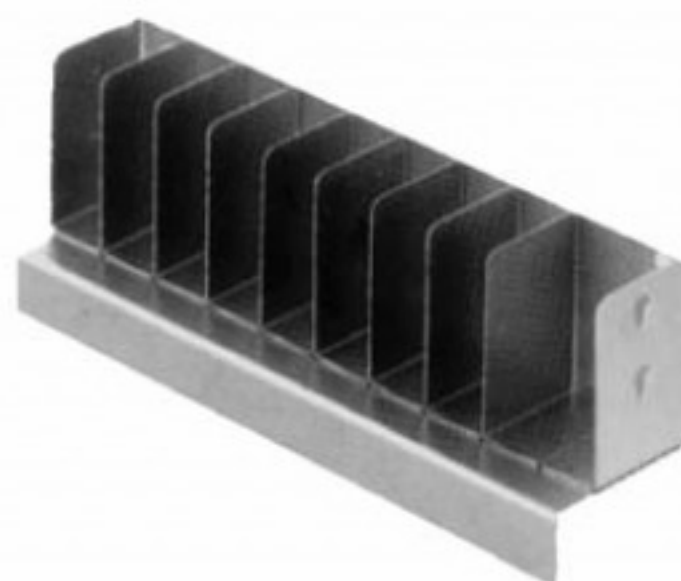

SX 259/00



SX 262/01



SX 270/01

>> autoklavierbar
>> autoclavable



SX 270/02

Reparaturanhänger Tyvek nicht dampfsterilisierbar
Repair tag „Tyvek“ not suitable for steam sterilization



SX 271/01

AA

AB

AC

AD

AE

AK

AR

KA

KM

KO

KP

KYE

XR

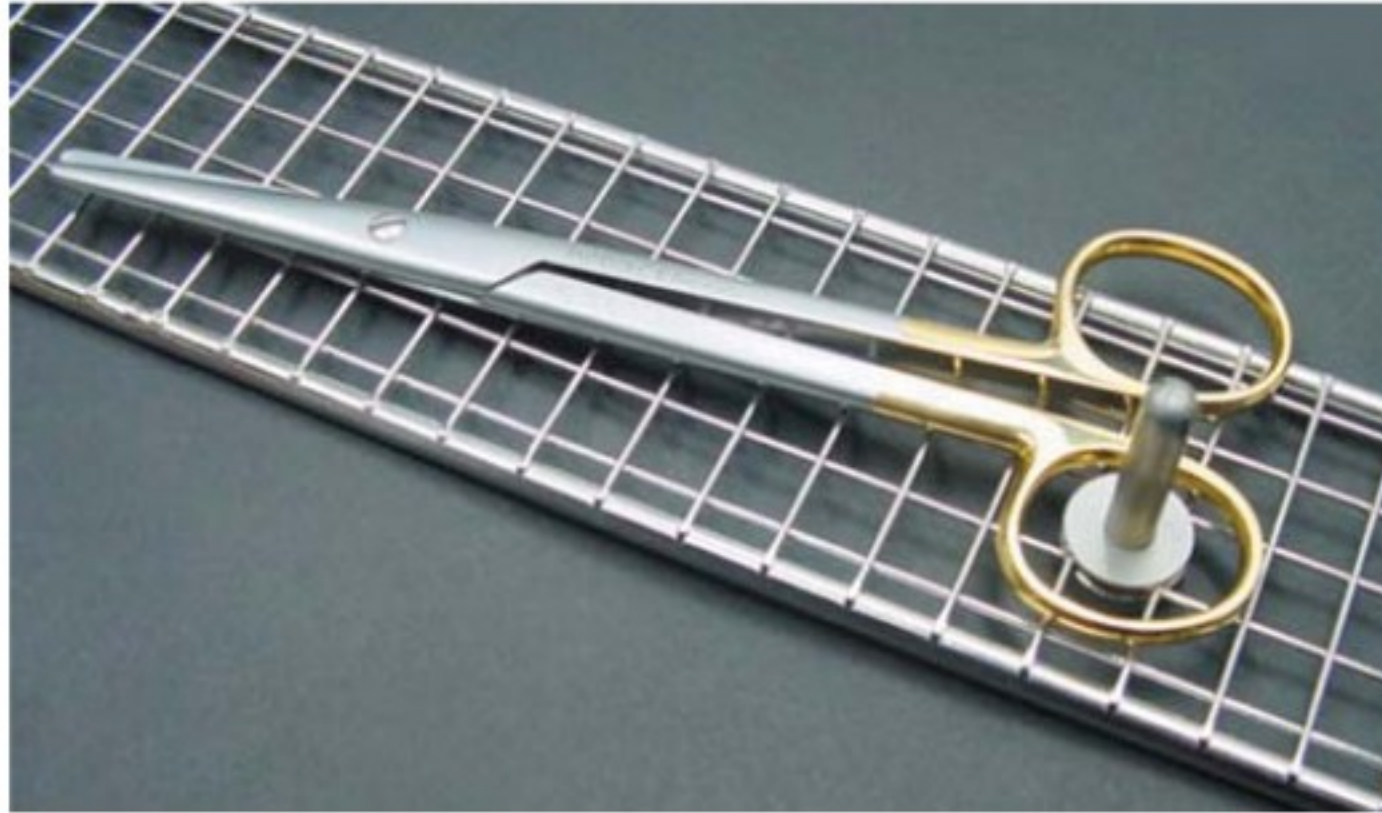
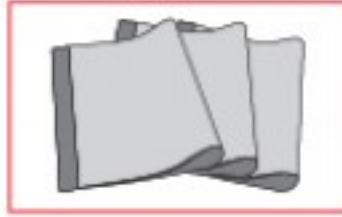

SX 301/01

für Instrumente
for instruments
para instrumentos
pour instruments
per strumenti

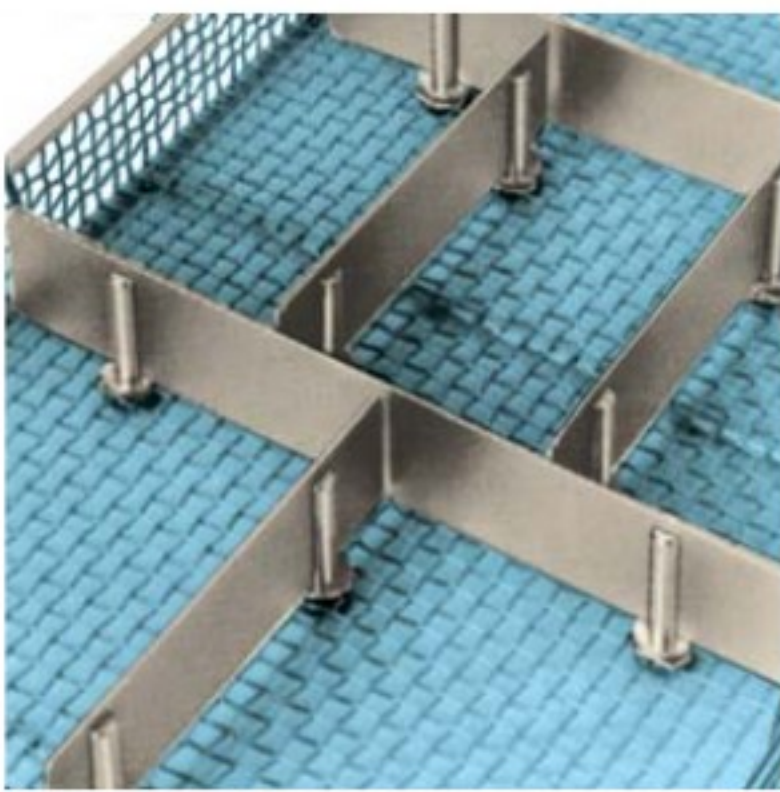

SX 301/02

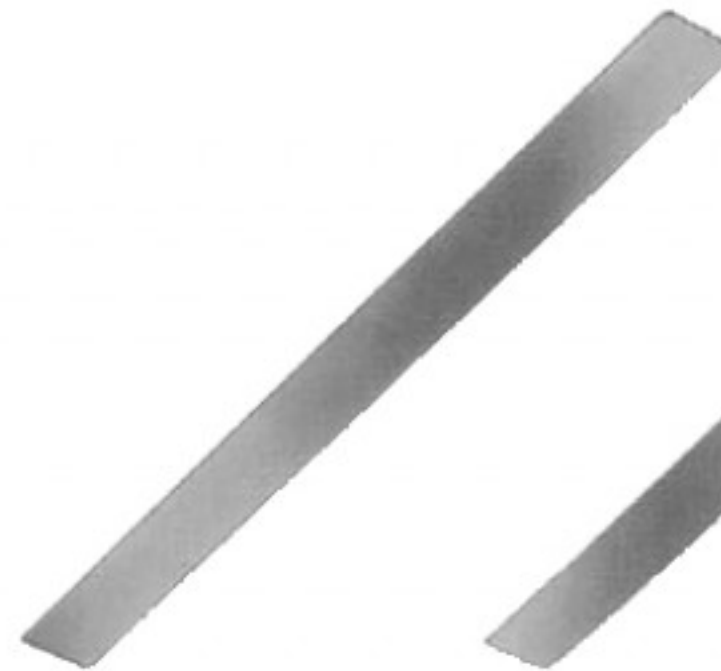

460 x 20 mm
SX 303/01



225 x 20 mm
SX 303/02



130 x 20 mm
SX 303/03



50 x 20 mm
SX 303/04



Größe / Size

- 110 mm SX 304/11
- 170 mm SX 304/17
- 230 mm SX 304/23
- 470 mm SX 304/47

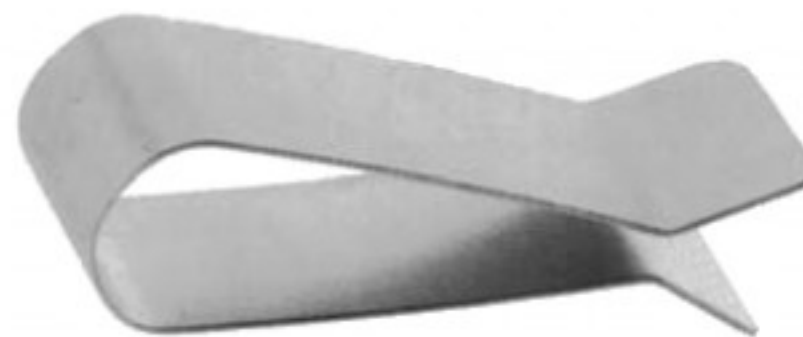

SX 306/01



Größe / Size

- Ø 7 - 12 mm SX 315/10
- Ø 12 - 16 mm SX 315/11
- Ø 16 - 26 mm SX 315/12
- Ø 26 - 36 mm SX 315/13
- Ø 36 - 45 mm SX 315/14

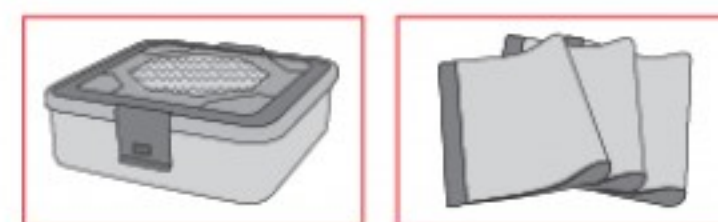

L(mm) B(mm)
115 30 SX 319/01



L(mm) B(mm)
230 30 SX 319/02

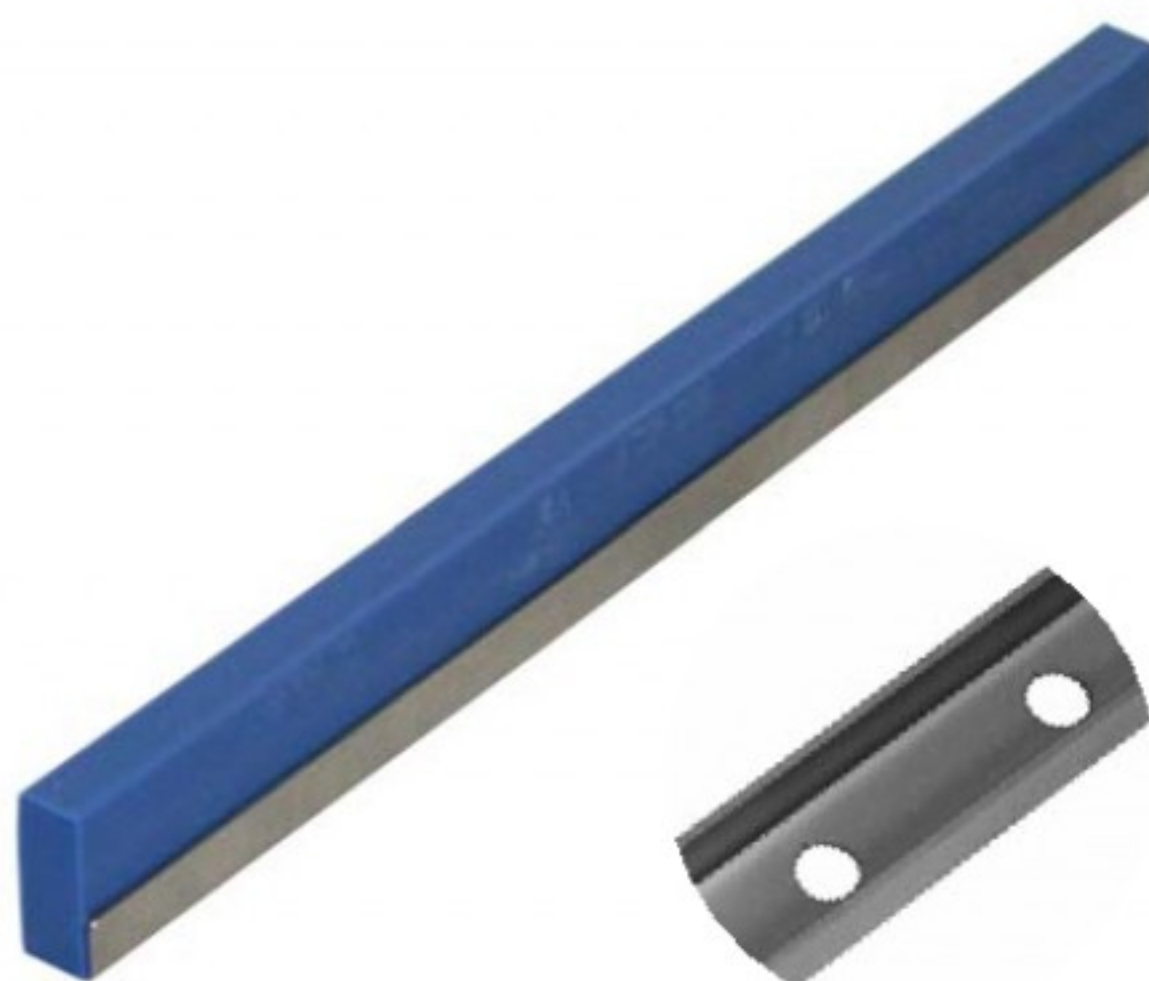

L(mm) B(mm) H(mm)
245 10 28 SX 410/50

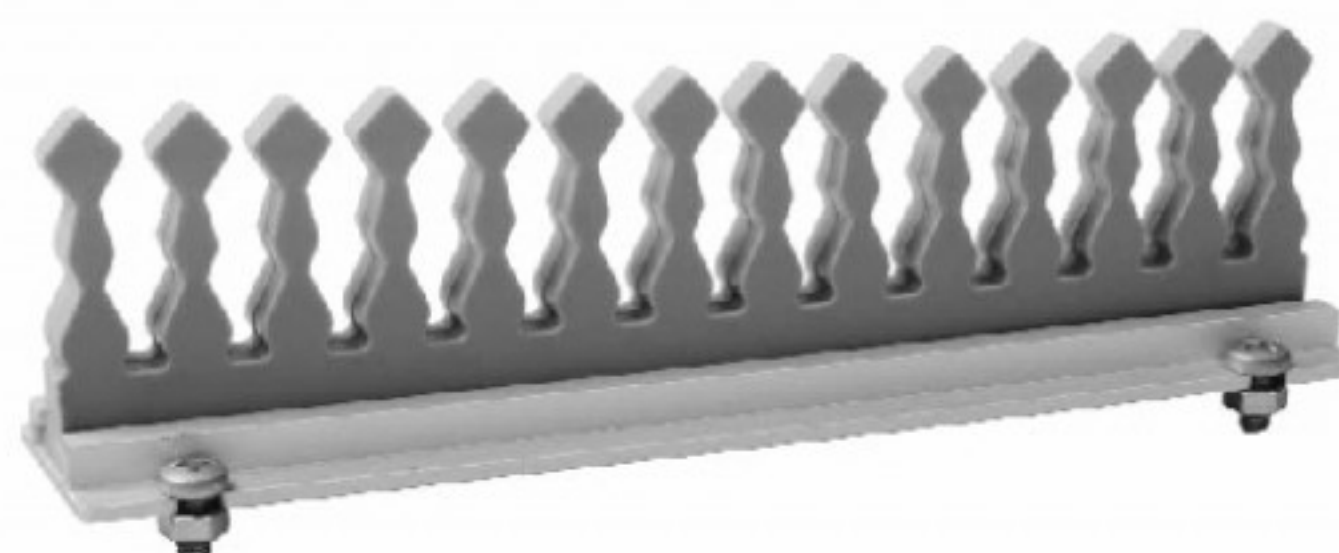

L(mm) B(mm) H(mm)
110 30 40 SX 412/01
160 30 40 SX 412/02
240 30 40 SX 412/03

AA

AB

AC

AD

AE

AK

AR

KA

KM

KO

KP

KYE

XR

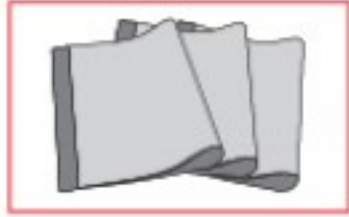

L(mm)	B(mm)	
275	125	SX 432/01
225	225	SX 432/02
300	300	SX 432/03
440	230	SX 432/04
520	230	SX 432/05



4mm - 6mm



SX 435/01



255 x 13 mm
SX 435/02

SX 435/00 = 2 x SX 435/01
1 x SX 435/02



SX 438/01



Füße für Siebkorb,
Containerboden gelocht

Stands for wire baskets,
Container bottom perforated

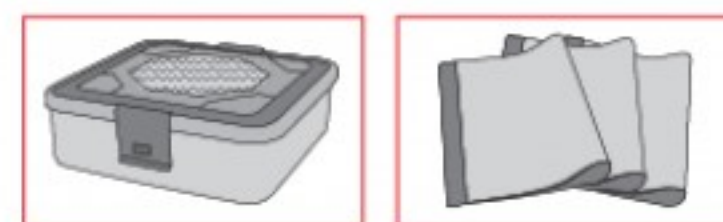

SX 444/01
30 x 30 mm

stainless steel



SX 444/02
50 x 30 mm



SX 444/03
90 x 30 mm



sterilisierbar
aus hitzebeständigem
Kunststoff

Sterilizable,
of heat-proof plastic

	30 x 30 mm	50 x 30 mm	90 x 30 mm
○	SX 445/01	SX 446/01	SX 447/01
●	SX 445/02	SX 446/02	SX 447/02
●	SX 445/03	SX 446/03	SX 447/03
●	SX 445/04	SX 446/04	SX 447/04
●	SX 445/05	SX 446/05	SX 447/05
●	SX 445/06	SX 446/06	SX 447/06
●	SX 445/07	SX 446/07	SX 447/07

AA

AB

AC

AD

AE

AK

AR

KA

KM

KO

KP

KYE

XR



2 x 9 x 25 mm SX 450/01
 2 x 16 x 25 mm SX 450/02
 3 x 25 x 25 mm SX 450/03



-  1,6 x 19,0 mm SX 451/01
-  2,0 x 19,0 mm SX 451/02
-  2,8 x 19,0 mm SX 451/03
-  3,2 x 25,4 mm SX 451/04
-  5,0 x 25,0 mm SX 451/05
-  10,0 x 19,0 mm SX 451/06



6,4 x 7,62 mm

-  SX 455/01
-  SX 455/02
-  SX 455/03
-  SX 455/04
-  SX 455/05
-  SX 455/06
-  SX 455/07
-  SX 455/08
-  SX 455/09



L(mm)	B(mm)	
60	40	SX 460/01
85	85	SX 460/02
100	140	SX 460/03
275	125	SX 460/04
245	245	SX 460/05

HF-ZUBEHÖR
HF-ACCESSORIES
AF-ACCESORIOS
HF-ACCESSOIRES
AF-ACCESSORI

XR

nopa[®] instruments



ENDOSKOPIE ENDOSCOPY ENDOSCOPIA ENDOSCOPIE ENDOSCOPIA

Anschlußkabel, Bi-Koagulations-Pinzetten
 Connection Cords, Bi-Coagulation-Forceps
 Cables de conexión, Pinzas para Coagulación
 Câbles de raccordement, Pincés pour Bi-Coagulation
 Cavi da connessione, Pinze per la Bi-Coagulazione

AA

AB

AC

AD

AE

AK

AR

KA

KM

KO

KP

KYE

XR

bipolar



MARTIN / BERCHTHOLD

300 cm XR 830/03
 500 cm XR 830/05

bipolar



ERBE/SELECT

XR 832/03
 XR 832/05

D=0,5 mm



E=Nadel



11,0 cm/4 ¹ / ₃ "	XR 898/11 D	XR 899/11 D
11,0 cm/4 ¹ / ₃ "	XR 898/11 E	XR 899/11 E

INDEX INSTRUMENTS

>> Klemmen • Hemostats • Pinzas hemostáticas Pinces hémostatiques • Pinze emostatiche	75–80	AA
>> Pinzetten • Forceps • Pinzas • Pinces • Pinze	81-98	AB
>> Scheren • Scissors • Tijeras • Ciseaux • Forbici	99-118	AC
>> Skalpelle • Scalpels • Bisturíes • Bistouris • Bisturi	119-124	AD
>> Naht • Suture • Sutura • Suture • Sutura	125-134	AE
>> Wundhaken • Retractors • Separadores • Ecarteurs • Divaricatori	135-140	AK
>> Diagnostik • Diagnostics • Diagnóstico • Diagnostic • Diagnostica	141-144	AR
>> Orthopädie • Orthopaedics • Ortopedia • Orthopédie • Ortopedia	145-146	KA
>> Otologie • Otology • Otología • Otologie • Otologia	147-148	KM
>> Rhinologie • Rhinology • Rinología • Rhinologie • Rinologia	149-150	KO
>> Ophthalmologie • Ophthalmology • Oftalmología Ophtalmologie • Oftalmologia	151-204	KP
>> Container System • Container System • Sistema de contenedor Système de conteneur • Sistema del contenitore	205-230	KYE
>> Endoskopie • Endoscopy • Endoscopia • Endoscopie • Endoscopia	231-234	XR

Anatomie des Auges
 Anatomy of the eye
 Anatomía de ojo
 Anatomie des yeux
 Anatomia di occhio

